

MIDLAND LMR

LAND MOBILE RADIO

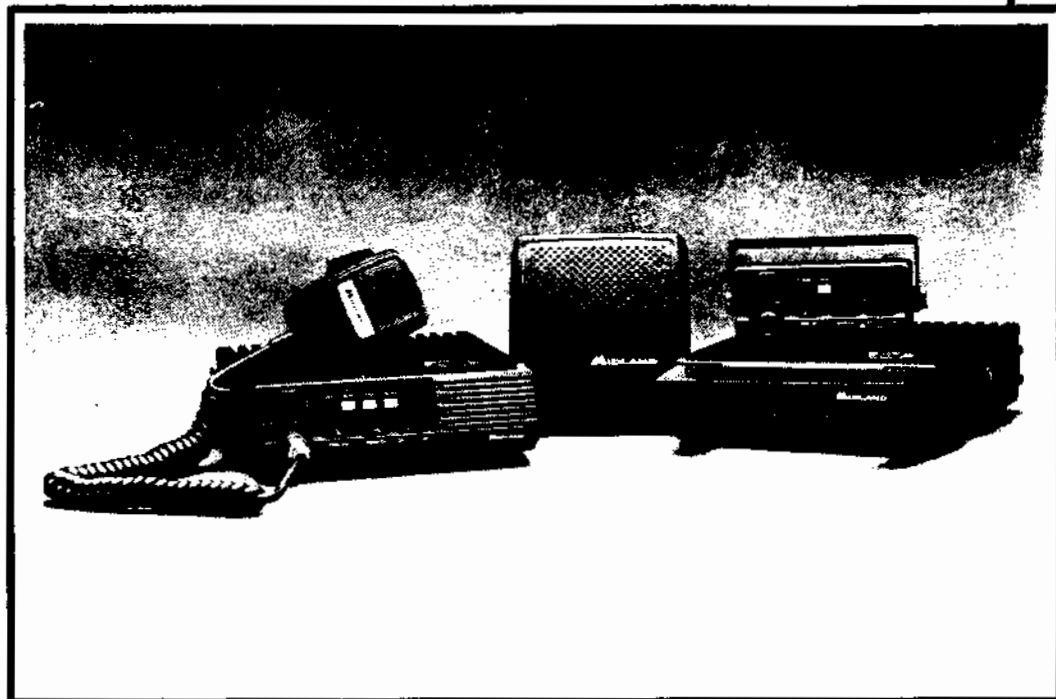

SERVICE MANUAL 70-0351A/B/C AND 70-0355A/B/C

FM TWO-WAY
LAND MOBILE RADIO
VHF LOW BAND
(29.7 - 36 MHz/36 -
42 MHz/42 - 50 MHz)
60 WATT

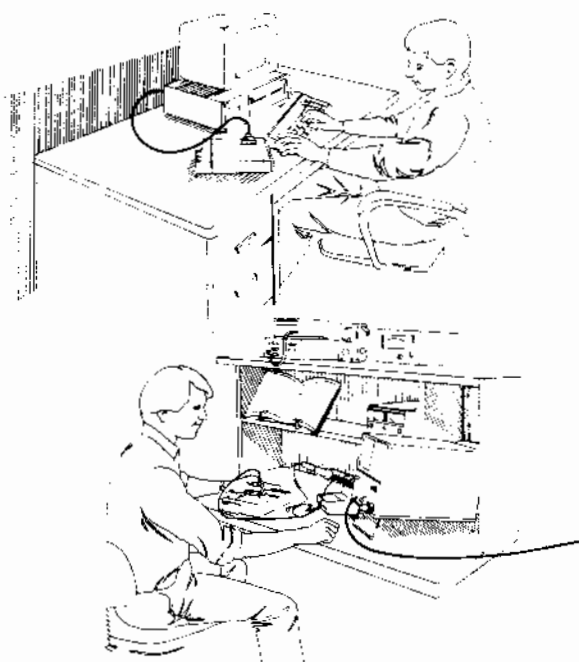

MANUAL NO. 70-351355
09-0351/0355-SM-7/91-2M

This user's manual is designed to facilitate the set-up and service of the MIDLAND 70-0351/0355 SYN-TECH XTR mobile transceivers. As necessary, user's manual supplements will be published and distributed on the following forms:

- Manual Addition (MA) For supplemental information useful in product service or improvement. Printed on BLUE paper.
- Change Notice (CN) For details about changes made during production by model and serial number. Printed on YELLOW paper.
- Manual Correction (MC) For correcting literature errors not related to production changes. Printed on GREEN paper.
- Technical Bulletin (TB) For solutions to field problems and tips for performance improvement. Printed on PINK paper.

Comments or suggestions concerning areas of manual improvement are welcome.

TABLE OF CONTENTS

Manual Supplement Information	ii
Table of Contents	iii

SECTION 1

GENERAL INFORMATION

Description	1 - 3
Specifications	1 - 3
Accessories	1 - 5

SECTION 2

PREPARATION

Preinstallation Check	2 - 3
Start-Up	2 - 3
Complete Realignment	2 - 4

SECTION 3

INSTALLATION

Installation	3 - 3
--------------------	-------

SECTION 4

SERVICING

Removing the TR-053 Board	4 - 3
Troubleshooting Charts	4 - 5
Component Replacement	4 - 17
Eliminating Radio Interference	4 - 21
DC Voltages	4 - 25

SECTION 5

CIRCUIT DESCRIPTIONS

RF Section	5 - 3
60-Watt PA Section	5 - 5
Logic Section	5 - 5
IC901 Pinouts	5 - 7

SECTION 6

DIAGRAMS

Block Diagram 6 - 3
Under-Dash Wiring Diagram 6 - 4
Trunk-Mount Wiring Diagram 6 - 5
Control Head Layouts 6 - 6
Under-Dash Control Head Schematic 6 - 7
Trunk-Mount Control Head Schematic 6 - 8
TR-053 Layout—Bottom View 6 - 9
TR-053 Layout—Top View 6 - 10
TR-053 Schematic Diagram 6 - 11
TR-053 Component Layout 6 - 12
TR-053 Transistor Schematic Pinouts 6 - 13
TR-053 Diode Schematic Pinouts 6 - 13
70-2157 (CTCSS) Schematic 6 - 14
70-2157 (CTCSS) Layout 6 - 15
Z-594 Layout 6 - 15
Z-593 Layout 6 - 16
Z-593 Interface Schematic 6 - 16
Under-Dash Exploded View 6 - 17
Trunk-Mount Exploded View 6 - 18

SECTION 7

PARTS

Parts List 7 - 3
Replacement Parts Ordering 7 - 13

SECTION 1 - General Information

1

SECTION 2 - Preparation

2

SECTION 3 - Installation

3

SECTION 4 - Servicing

4

SECTION 5 - Circuit Descriptions

5

SECTION 6 - Diagrams

6

SECTION 7 - Parts

7

SECTION 1

GENERAL INFORMATION

GENERAL INFORMATION

70-0351/0355

NOTES

DESCRIPTION

The 70-0351/0355 MIDLAND SYN-TECH XTR transceivers are programmable frequency-synthesized two-way FM mobile radios that operate in the low-band VHF frequency range. They are programmable for up to 22 channels, or up to 99 channels with plug-in option.

The 70-0351/0355 are designed to operate within one of three frequency ranges: 29.7—36 MHz (A-Band), 36—42 MHz (B-Band), or 42—50 MHz (C-Band). Transmit RF power is programmable for 2—60 watts.

There are two types of control head configurations for the SYN-TECH XTR. Either the entire radio can be mounted under the vehicle dashboard (model number 70-0351), or the bulk of the radio can be placed under a seat or in the trunk, with only the control panel mounted in the operator's reach (model number 70-0355). If the 70-0351 is purchased, the XTR is shipped with the Control Panel attached. If the 70-0355 is purchased, the XTR is shipped with a cable-interface board and handle assembly mounted in place of the Control Head on the transceiver, and a separate Control Head. The two units must be connected together with a multi-conductor cable when installed.

1**SPECIFICATIONS**

Refer to EIA-152-C, EIA/TIA-204-D, and DOC RSS-119, Issue 3 for standard of performance and method of measurement.

GENERAL**OPERATING FREQUENCY RANGE:**

A-Band: 29.7—36 MHz

B-Band: 36—42 MHz

C-Band: 42—50 MHz

COMMUNICATION SYSTEMS: Press-to-talk (1 or 2 frequency simplex)**CHANNEL SPACING:** 20 kHz**CHANNEL STEPPING:** 2.5 kHz**CHANNELS:** 22 or 99 (optional)**REFERENCE OSCILLATOR:** Microcomputer controlled**DUTY CYCLE:** 1 minute TX, 4 minute RX**POWER SUPPLY:** 13.6 V DC negative to ground**OPERATING VOLTAGE RANGE:** 12.2 to 15.0 V**ABSOLUTE VOLTAGE RANGE:** 10.9 to 16.3 V

GENERAL INFORMATION

70-0351/0355

CURRENT DRAIN:

Standby: 0.3 A (varies with options)
Receive (at full rated audio): 1.0 A (approx.)
Transmit (full power): 10.0 A (approx.)

RF IMPEDANCE: 50 Ω unbalanced

OPERATION TEMPERATURE: -30° C to $+60^{\circ}$ C

RELATIVE HUMIDITY: 90% at 50° C $\pm 2^{\circ}$ C

SHOCK: MIL 810D 516.3 Procedure I

VIBRATION: MIL 810C 514.2 Procedure VIII-V Category f
MIL 810D Method 514.3I-3.2.10

DIMENSIONS (H x W x D):

Dash-mount: 2.25 x 7.75 x 8.86 in (57 x 196 x 225 mm)
Trunk-mount: 2.25 x 7.75 x 9.65 in (57 x 196 x 245 mm)
Remote Control Head: 2.25 x 4.75 x 3.31 in (57 x 120 x 84 mm)
Speaker: 4.81 x 4.81 x 2.87 in (121 x 121 x 72 mm)

WEIGHT:

Dash-mount: 5.7 lb (2.6 kg)
Trunk-mount: 6.1 lb (2.8 kg)

TRANSMITTER

RF POWER OUTPUT (programmable): 2—60 W, dual RF power levels

FREQUENCY STABILITY (-30° C to $+60^{\circ}$ C): $\pm 0.0005\%$ standard, $\pm 0.0002\%$, optional

MODULATION (direct FM): 16K0F3E, 5 kHz maximum

FREQUENCY SEPARATION:

A-Band: 6.3 MHz
B-Band: 6 MHz
C-Band: 8 MHz

SPURIOUS & HARMONICS: -63 dB

FM HUM & NOISE: -50 dB

AUDIO RESPONSE: per EIA and DOC specifications

AUDIO DISTORTION (at 60% deviation): 3% or less at 1000 Hz

OUTPUT IMPEDANCE: 50 Ω

RECEIVER

FREQUENCY STABILITY (-30°C to $+60^{\circ}\text{C}$): $\pm 0.0005\%$ standard, $\pm 0.0002\%$ optional

SENSITIVITY (12 dB SINAD): $0.30\ \mu\text{V}$

SELECTIVITY ($\pm 30\ \text{kHz}$): $-80\ \text{dB}$

FREQUENCY SEPARATION:

A-Band: 6.3 MHz

B-Band: 6 MHz

C-Band: 8 MHz

ACCEPTABLE RADIO FREQ. DISPLACEMENT: $\pm 2.0\ \text{kHz}$ minimum

SPURIOUS REJECTION: $-80\ \text{dB}$

INTERMODULATION: $-80\ \text{dB}$

SQUELCH SENSITIVITY: $0.18\ \mu\text{V}$ maximum

AUDIO OUTPUT:

Int: 3 W at 3% distortion or less

Ext: 10 W at 3% distortion or less (into $3.2\ \Omega$)

(Trunk-mount models measured at control head accessory connector with 4 meter maximum control cable. For longer control cables, measurement must be made at accessory connector on rear of radio.)

INPUT IMPEDANCE: $50\ \Omega$

— All specifications subject to change without notice —

ACCESSORIES**OPTION KITS:**

70-2180	99 Channel Option
70-2119	2 ppm Frequency Stability Kit
70-2120	2.5 ppm Frequency Stability Kit
70-2163	2nd IF Reverse Injection Kit
70-2963-1	MIL 810 C/D dust/rain/salt fog Kit (T/M Control Head only)
70-2963-2	MIL 810 C/D dust/rain/salt fog Kit (T/M Main Unit only)

GENERAL INFORMATION

70-0351/0355

SIGNALLING OPTIONS

70-2157	CTCSS/DCS Filter
70-2410	Digital Voice Storage/In Band Repeater (Requires 2413A Interface Board)
70-2412A	Rolling Code Variable Split Band Scrambler (Requires 2413A Interface Board)
70-2413A	Interface Board
70-2415	2 Tone Sequential Decoder
70-2416	Private Squelch
70-2418	Burst Tone Encoder
70-2419	Reverse Burst Generator
70-2420A	DTMF Decoder

SPEAKERS AND MICROPHONES

70-2302	Weatherproof Microphone
70-2306	Microphone
70-2103A	DTMF Microphone with Up-Down Channel Switch w/6 Pin Jack Kit (70-K33-1)
70-2104A	DTMF Microphone with Up-Down Channel Switch and ANI w/ 6 Pin Jack Kit (70-K33-1)
70-2305B	Dynamic Base Station Microphone (w/70-K33-1)
70-2311	Telephone Handset (70-K37 required)
70-2195	CTCSS Microphone Hang-Up switch
70-2355	15 Watt Remote Speaker
70-2356	15 Watt Weatherproof Speaker
70-2365	15 Watt Horn Speaker
70-2325	Heavy Duty Amplified Condensor DTMF Microphone (w/ illuminated keypad)

MISCELLANEOUS

70-2249	Conversion Kit — Trunk Mount to Dash Mount
70-2250	Conversion Kit — Dash Mount to Trunk Mount
70-7070	Weatherproof Housing
70-2218	Ignition Relay Kit
70-2925	Memory Back up Kit (Short Term)
70-2926	Memory Back up Kit (Long Term)
70-2197	Electronic Noise Filter, 25 A

SECTION 2

PREPARATION

PREPARATION

70-0351/0355

NOTES

PREINSTALLATION CHECK

NOTE: Alignment will require a programmer: either the 70-1080A programmer (with Version 15.1 firmware or later) or the 70-1489 PC Programming software.

• Setup

1. Remove the four securing screws on the cover and the cover itself.
2. If not already in place, connect the proper Control Head to the TX/RX Unit.
3. Connect a resistive, 50- Ω RF load (with a wattmeter) to Antenna Connector J501.
4. Connect 13.6 V DC power to J415.
5. Turn the radio on, turn MON on, turn selective signaling options off.

• Carrier Frequency

6. Initiate transmit on any channel. Measure transmitted RF carrier frequency without modulation and, if needed, set carrier frequency within ± 100 Hz of channel frequency using the programmer. Refer to the appropriate manual for details.

7. RF output power is adjustable through the 70-1080A programmer. Initiate transmit on any channel. Measure power of RF output at 50- Ω Antenna Connector J501 and, if needed, adjust RF output power to obtain 60 W using the programmer. J402 is the interface connector between the transceiver and the programmer.

• Maximum Deviation

8. Select a channel with transmit frequency of 30 MHz for A-Band, 36 MHz for B-Band, or 42 MHz for C-Band. If CTCSS or DCS is used, be sure the channel is programmed to send the same frequency.
9. Disconnect the hand microphone from its front panel receptacle J301. Apply 3 V_{rms} of 1000 Hz signal to pin 1 of Mic Jack J301, then initiate transmit by grounding pin 4. Measure total carrier deviation. If it is not below ± 5 kHz (including optional CTCSS/DCS signal), see MODULATOR ALIGNMENT on page 2 - 5.

START-UP

1. Program the radio customer frequencies and select features using the MIDLAND 70-1080A SYN-TECH XTR/II Programmer and its instruction manual.
2. The 70-0351/0355 Units are capable of operating across a wide band of channel frequencies; frequency selective circuits do not require realignment after the units are programmed with customer channel frequencies. After programming, only a general check of proper operation is needed. If any minor adjustments are necessary, refer to COMPLETE REALIGNMENT. These adjustments are of a general nature and do not require atypical equipment.
3. Install the radio into the vehicle (refer to Section 3 for instructions).

CAUTION: Do not ground any speaker wires because they are all electrically hot (each wire is connected to a differential audio amplifier output).

NOTE: You must use the 70-1080A Programmer, the 70-1083 Jumper Plug, or 70-1489 PC Programming software to set Carrier Frequency, Maximum Deviation and RF Output Power.

PREPARATION

70-0351/0355

COMPLETE REALIGNMENT

Complete realignment is only needed when a component that affects alignment has been replaced. RADIO REPROGRAMMING WITH TEST FREQUENCIES IS REQUIRED.

Table 2 - 1 — Test Equipment Required

TEST INSTRUMENT	INSTRUMENT CAPABILITIES	USE
Regulated DC Power Supply	13.6 V DC, 15 A, adjustable voltage	Radio power source
RF Wattmeter	75 W, 29.7—50 MHz, 50 Ω circuit	Transmitter power measurements
RF Load Resistor	50 Ω @ 100 W	Antenna dummy load
Frequency Modulation Meter	29.7—50 MHz, peak- responding, ± 5 kHz range	Modulation level measurements
Frequency Meter or Frequency counter	29.7—50 MHz, 1.0 ppm accuracy	Carrier frequency measurement
Audio Generator	1000 kHz sine wave, 0—4 V_{rms} output	Modulation level measurements
RF Signal Generator	29.7—50 MHz range 0.1—1 $K\mu V$ output, 3 kHz FM mod. with 1 kHz tone	All receiver measurements
Distortion Analyzer	1 kHz notch, 1% measuring range	Receiver performance test and IF alignment
Load Resistor (audio)	3.2 Ω , 20 W	Speaker load for all receiver measurements
AC Voltmeter	10 mV to 3 V_{rms}	Audio level adjustments
Oscilloscope	DC to 500 kHz bandwidth	DCS analysis
Digital Multimeter	0.1 to 20 V DC	Test point measurements and power supply setup
Programmer	MIDLAND 70-1080A (Version 15.1 firmware) or 70-1489 PC Programming software	Manual radio control

SET UP

1. Remove the four securing screws from the bottom cover and the cover itself.
2. If not already in place, connect the proper Control Head to the TX/RX Unit.
3. Connect a resistive 50-Ω RF load and a wattmeter to Antenna Connector J501.
4. Connect 13.6 V DC power to transceiver J415.
5. Connect a 3.2-Ω, 20-W resistor to pins 4 and 6 of the Accessory Plug. The jumper between pins 5 and 6 must be temporarily disconnected to make this connection. The resistor serves as a constant load to replace the speaker's inconsistencies.

CAUTION: Both speaker terminals are LIVE! Never ground either one. Connect grounded receive-audio measuring equipment to only one side of the speaker, and chassis ground. Normally, voltage measurements will be half of true values.

6. Turn the radio on, set the Volume control to a mid-position, and set the Squelch control fully counterclockwise.
7. Connect the programmer to Programming Port J402. Upload the radio programming Data-Packet into the programmer and initiate its Remote Control Mode. Refer to the appropriate manual for instructions.

SYNTHESIZER ALIGNMENT

• **VCO Resonance**

1. Select the Remote-Control Mode of the Programmer and change the RX and TX test frequencies to 30.00 MHz for A-Band, 36.00 MHz for B-Band, or 42.00 MHz for C-Band.
2. Adjust Channel RX Tank L713 to obtain 1.5 V DC on CM701 pin 1.

3. Activate the transmit mode (using the Programmer). Adjust Channel TX Tank L733 to obtain 1.5 V DC on CM701-pin 1.

• **Crystal Type Selection**

4. Select the Test Mode of the Programmer, and choose Crystal Type as follows: X101 is marked '1', select Type 1; if X101 is marked '2', select Type 2; if X101 is marked '3', select Type 3. Refer to Crystal Alignment (page 2 - 8) for complete alignment instructions.

• **Reference Oscillator**

5. Initiate transmit on any channel. Measure transmitted RF carrier frequency without modulation and, if necessary, adjust L101 to bring the carrier frequency to within ±100 Hz of channel frequency.

60-WATT PA SECTION ALIGNMENT

1. Change the TX test to 30 MHz for A-Band, 36 MHz for B-Band, or 42 MHz for C-Band. Activate transmit mode.
2. Set RF output power to 60 W at J501 using the programmer.

MODULATOR ALIGNMENT

Always perform Modulator Alignment in its entirety—the following adjustments are interactive.

• **Modulation Limiting**

1. Disconnect the hand microphone from its front panel receptacle J301.
2. Apply 3 V_{rms} of 1000 Hz signal to pin 1 of Mic Jack J301, then initiate transmit (if not using the programmer, ground J301 pin 4).
3. Measure total carrier deviation and, if needed, adjust modulation limiting to obtain ±5 kHz using the programmer.

• **Microphone Gain**

4. No alignment for microphone gain is required.

PREPARATION

70-0351/0355

RECEIVER ALIGNMENT

1. Change the RX test frequency to 33.1 MHz for A-Band, 39.1 for B-Band, or 46.1 for C-Band.

• First Injection

2. No adjustment for first injection is required.

• Preselector Alignment

3. No adjustment for the preselector (L201, L202, L203, L204, L205, L206, L207, and L208) is required.

• Quadrature Detector

4. Apply 1 mV of modulated (by 1 kHz tone at ± 3 kHz deviation) on-channel RF signal to Antenna Jack J501. Adjust Detector L250 for maximum audio output.

• First IF

5. Apply enough modulated (by 1 kHz tone at ± 3 kHz deviation) on-channel RF signal to maintain 12 to 15 dB SINAD. Adjust L245, L247, L803 and L804 for maximum SINAD, reducing the RF signal generator output as necessary to stay between 12 and 15 dB SINAD.

NOTE: Do not adjust L801 or L802 unless appropriate test equipment is available for performing the "Noise Blanker Tuning" steps below. Normally, these coils are tuned for optimum sensitivity as are L803 and L804, then are retuned slightly for optimum noise blanker effectiveness. If the required test equipment is not available, skip steps 6 through 14. If coils L801 or L802 were replaced, they may be tuned for best sensitivity after adjustment of L245, L247, L803 and L804. Noise blanker performance specifications, however, may not be met.

• Noise Blanker Tuning

This procedure requires the additional test equipment shown in **Table 2 - 2**.

6. Adjust the pulse generator to obtain a 10 nsec wide pulse, as shown in **Figure 2 - 2**. Set the pulse period controls to obtain 200 μ sec between pulses (the pulse period is easier to observe on an oscilloscope if the pulse width is temporarily increased by about 10 times).
7. Temporarily disable the pulse generator.
8. Using coax cable of minimum convenient length, connect the pulse generator, the RF signal generator, and the radio to the two-way power divider.
9. Disable the noise blanker by placing SW801 to the OFF position.
10. Apply an on-channel signal to obtain 12 dB SINAD, then increase the RF generator output by 40 dB.
11. Enable the pulse generator to produce the 10 nsec pulses. Adjust pulse amplitude to return SINAD reading to 12 dB.
12. Switch SW801 to the ON position. The SINAD reading should improve.
13. Reduce the RF generator output until a 12 dB SINAD reading is obtained.
14. Using a non-metallic tool, slowly tune L801 (clockwise or counter-clockwise, as required) for best SINAD. The amount of L801 adjustment required should be slight. Tune L802 in the same manner. Repeat this step. Noise blanker tuning is complete.

Table 2 - 2 — Noise Blanker Test Equipment

TEST INSTRUMENT	CAPABILITIES	SUGGESTED MODEL
Pulse Generator	Pulse Rate: 5000 pulses per second Pulse Width: Adjustable to 10 ns at 1/2 amplitude. Output: Continuously variable from 0.1 to 10 V peak into 50 Ω	Hewlett Packard 8012B or similar
Power Divider, 3 port:	50 Ω each port, 6 dB attenuation, DC to 50 MHz as defined in EIA Standard RS-204C or RS-204D Appendix A.	Mini-Circuits model 2FRSC-2050 or similar

2

• Tight Squelch

15. Set the front panel Squelch control to maximum (full clockwise). Set Squelch Range RV241 fully counter clockwise.
16. **If filter FL801 has been removed from your radio:** Apply 0.4 μV of unmodulated on-channel RF signal to the 50-Ω antenna connector.

For all other radios: Apply 1.5 μV of unmodulated on-channel RF signal to the 50-Ω antenna connector.
17. Adjust Squelch Range RV241 clockwise until squelch just opens (audio on).

CTCSS/DCS (If Installed)

1. Enter DCS code +023, and adjust VR1 so that DCS deviation is at 0.75 ±0.1 kHz.
2. While observing recovered modulation on an oscilloscope, fine tune RV401 for a square DCS waveform as shown.
3. Readjust DCS deviation to 0.75 ±0.1 kHz.
4. Set frequency to CTCSS at 250.3 Hz. Adjust RV401 for 0.75 ±0.1 kHz
5. Repeat step 2.
6. Check CTCSS so that deviation is in 0.6—0.9 kHz range.

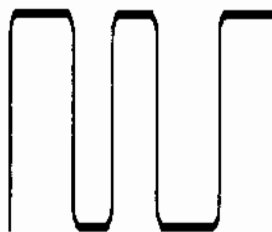

CORRECT

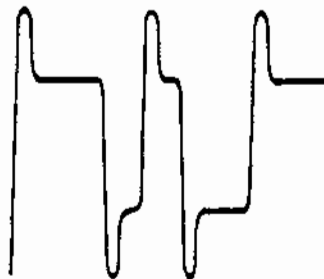

INCORRECT

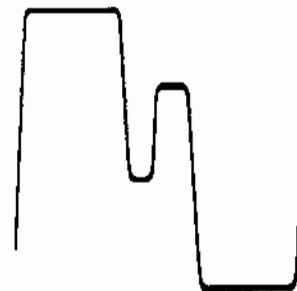

INCORRECT

PREPARATION

70-0351/0355

CRYSTAL ALIGNMENT

This alignment is required when a part in the reference oscillator circuit is replaced. This alignment is not needed during normal maintenance and radio alignment or programming.

When parts in the reference oscillator circuit are replaced, including the crystal, it is necessary to select the temperature compensation data of the microcomputer in accordance to the crystal markings. There are three types of crystals as (see **Table 2 - 3**). There are two ways to determine what type of crystal you have, either by the color of the dot on the top of the crystal or the type number on the side. See the example shown in **Figure 2 - 2**. See **Figure 2 - 1** for crystal location.

The procedure varies depending on what programmer is used. Proceed to the correct instructions for the programmer you are using.

• 70-1080A Programmer

Refer to the 70-1080A Programmer's Manual for more information.

1. Connect the radio to power and test equipment as described under the alignment procedure section of the service manual.
2. Connect the 70-1080A programmer to the radio.
3. Upload the contents of the radio into the 70-1080A programmer.
4. Enter the test mode by pressing **CH, 0**, then **ENT**.
5. Enter the correct **RX** (receive) and **TX** (transmit) test frequency for the radio. **NOTE:** The **CTCSS** and **DCS** does not need to be used for this test.
6. Press **GRP, 4**, then **ENT**. **'XTAL CHANGE OK ?'** will be displayed.
7. Press **ENT**. **'XTAL TYPE SELECT'** will be displayed. Determine the type of crystal the radio has installed as shown in **Figures 1** and **2** and enter the correct type as shown in **Table 2 - 3**.

8. Press **ENT**. **'DA CONTROL'** will be displayed.
9. Press **3**, then **ENT**. **'FO CONTROL'** with a number (0 — 63) on the bottom line, representing the adjustment point of the reference oscillator frequency trim, will be displayed.
10. Measure the temperature of the body of R107 using a contact type thermometer. You must hold the thermometer on R107 for at least one minute before taking the temperature reading. R107 is located under the VCO shield (see **Figure 2 - 1**).
11. Using a digital voltmeter, measure the DC voltage on pin 60 of the microcomputer.
12. Find the measured temperature of R107 in **Table 2 - 4** and find the corresponding voltage for the type of crystal installed. Compare this voltage to that measured in step 11.
13. If the voltage does not match within 0.02 V DC, adjust it by using the **UP** or **DOWN** keys on the 70-1080A programmer until the DC voltage on pin 60 of the microcomputer is correct. Typical setting should be between 30 — 40.
14. When complete press **FNC**, then **OPT**. **'DA DATA PROG END'** will be displayed.
15. Initiate transmit and adjust L101 to within ± 100 Hz of test frequency.
16. Return the radio to normal operation.

• 70-1489 Computer Based Programmer

Refer to the 70-1489 Computer Based Programmer's Manual for more information.

1. Connect the radio to power and test equipment as described under the alignment procedure section of the service manual.
2. Connect the radio to the computer as described in the Computer Based Programmer's manual.
3. Upload the contents of the radio into the computer.

4. Enter the test mode of the program.
5. Select **RX-TX** in the **TEST MODE** and press **ENTER**.
6. Select **TX** in the **RX-TX MODE** and press **ENTER**.
7. Enter the correct **RX** (receive) and **TX** (transmit) test frequency for the radio. **NOTE:** The **CTCSS/DCS** tones/codes do not need to be used for this test. Do not leave the **CHANNEL DATA FORM** screen at this time.
8. Measure the temperature of the body of **R107** using a contact type thermometer. You must hold the thermometer on **R107** for at least one minute before taking the temperature reading. **R107** is located under the **VCO** shield (see **Figure 2 - 1**).
9. Determine the type of crystal the radio has installed as shown in **Figures 2 - 1** and **2 - 2**.
10. Using a digital voltmeter, measure the DC voltage on pin 60 of the microcomputer.
11. Find the measured temperature of **R107** in **Table 2 - 4** and find the corresponding voltage for the type of crystal installed. Compare this voltage to that measured in step 10. If the voltage is within 0.02 volts DC, then return the radio to normal operation. Otherwise:
12. Press **ESC** then **ENTER**.
13. Select **TX-CONTROL** in the **TX MODE** and press **ENTER**.
14. Use the **DOWN** arrow to select **CRYSTAL TYPE** and press **ENTER**. This will open the choice window.
15. Select the correct crystal type that the radio has and press **ENTER**.
16. Use the **UP** arrow to select the **REFERENCE FREQUENCY ADJUSTMENT**.
17. Using the **F5 — F8** keys, adjust the voltage to within 0.02 V DC of the voltage determined in step 11. The typical setting of the **REFERENCE FREQUENCY ADJUSTMENT** should be between 30 — 40. Press **ENTER** after each entry of the **F5 — F8**. After completion of the adjustment of the voltage on pin 60 of the microcomputer, press **ESC**.
18. Select **SAVE-TX** in the **TX MODE** and press **ENTER**.
19. Initiate transmit and adjust **L101** to within ± 100 Hz of test frequency.
20. Return the radio to normal operation.

2

PREPARATION

70-0351/0355

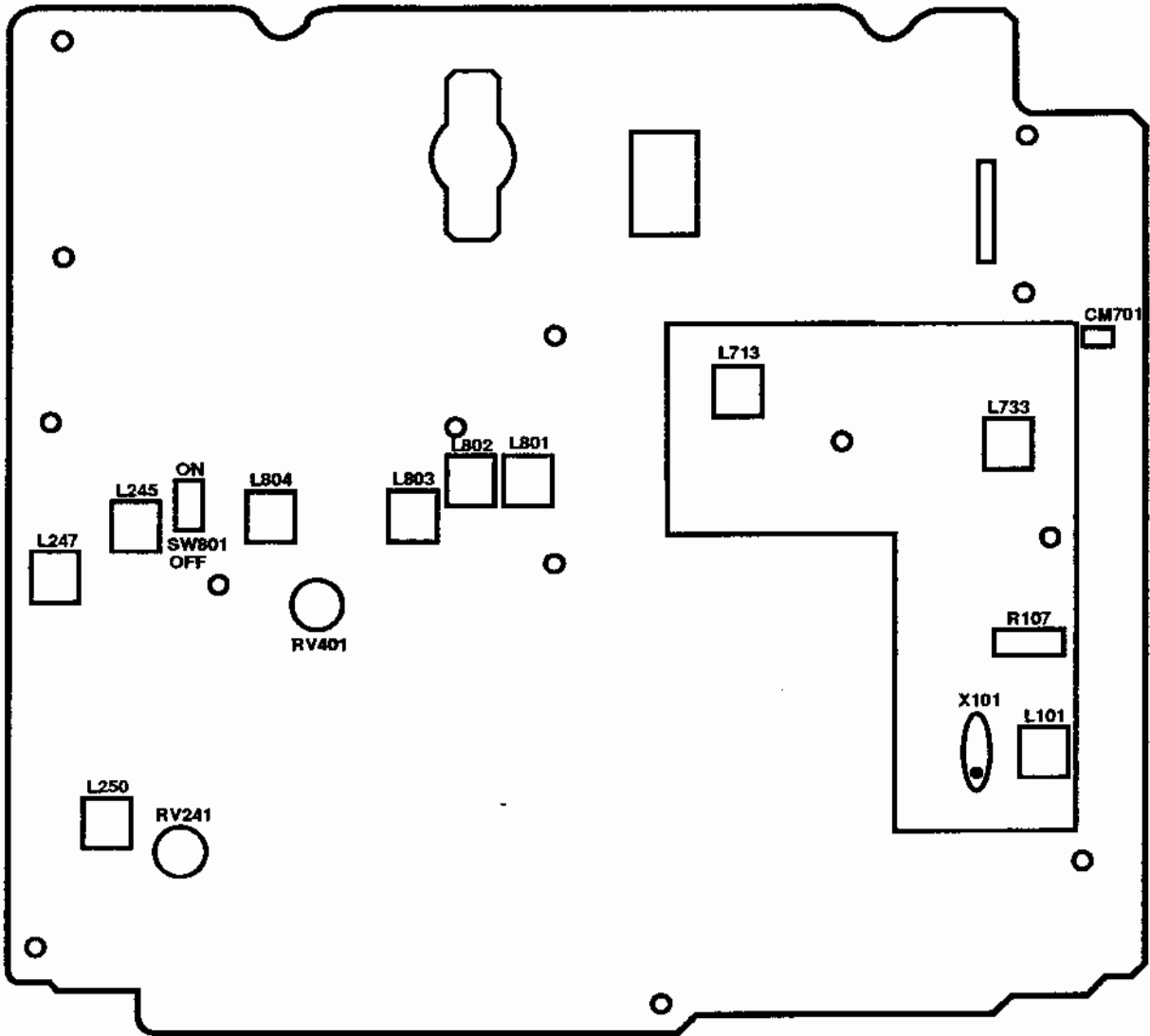

Figure 2 - 1 Adjustment Map — TR-053 Board

Table 2 - 3

CRYSTAL TYPE	I	II	III
CRYSTAL TYPE COLOR OF DOT ON TOP	BLACK	BLUE	RED
CRYSTAL TYPE TYPE NO. ON SIDE	1	2	3
TYPE NO. TO ENTER IN PROG MODE	1	2	3

Figure 2 - 2

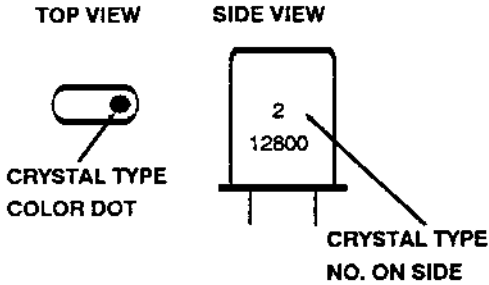
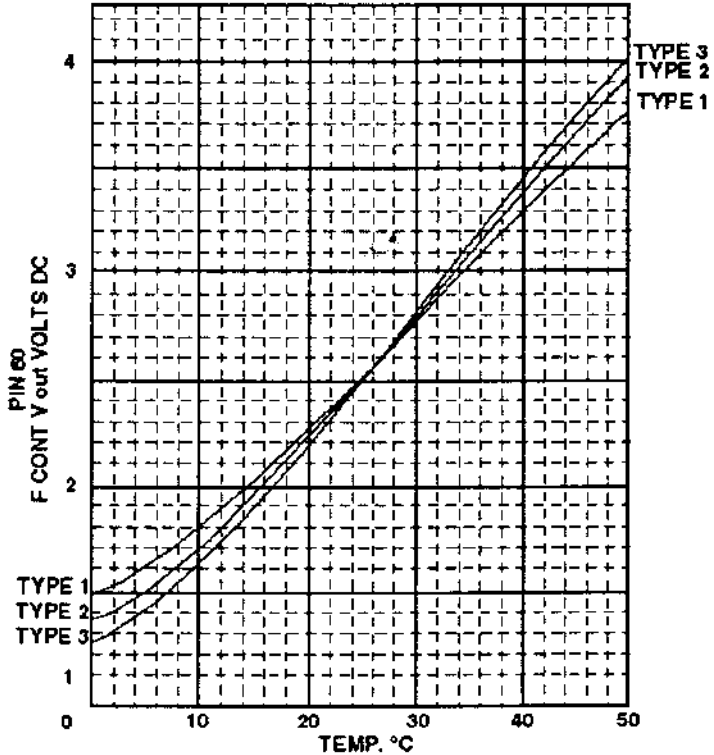

Table 2 - 4



PREPARATION

70-0351/0355

NOTES

SECTION 3

INSTALLATION

INSTALLATION

70-0351/0355

NOTES

INSTALLATION

MOUNTING

• Under-dash

The 70-0351A/B/C mounting bracket slides into the transceiver siderails and provides a 3.25" x 7.75" flat surface across the transceiver top with holes for bolting to a flat surface in the vehicle. $\frac{5}{32}$ " holes must be drilled in the mounting surface to accept the four $\frac{3}{8}$ " screws and washers provided.

• Trunk-Mount

The operator controls for the 70-0355A/B/C transceiver are inside a compact control head for operator access, while the bulk of the transceiver is located in a separate remotely mounted unit. It does not have an internal speaker. Instead, a separate 3.2 Ω external speaker (included with the 70-0355 package) must be installed and connected to the Control Head.

The cable that interconnects the Control Head to the trunk unit is four meters long and flat for laying under carpeting. The cable must not lay near hot areas (above the catalytic converter, for example), or against sharp edges.

A trunk unit mounting tray is provided with each transceiver. The flat tray is 7.5" square and must be bolted to a surface where the trunk unit will mount. $\frac{5}{32}$ " holes must be drilled in the mounting surface to accept the four $\frac{3}{8}$ " screws and washers provided. The 13" x 8" x 3" trunk unit then clips onto the tray.

A Control Head mounting bracket is provided with each transceiver. Its surface is $\frac{3}{4}$ " wide and 4" long with two screw holes 2" apart. $\frac{5}{32}$ " holes must be drilled in the mounting surface of the vehicle to accept the $\frac{3}{8}$ " screws and washers provided. The Control Head and Bracket assembly is 2 $\frac{1}{2}$ inches deep. At least $\frac{3}{4}$ " of additional depth is needed for the connectors that attach to the rear of the Control Head.

POWER

• Connections

For Under-Dash units, the Power/Accessory Cable is equipped with two unterminated 14 gauge wires two meters in length for connection to the vehicle electrical system. For Trunk-Mount units, the 70-2212B Power Cable is equipped with two unterminated 12 gauge wires six meters in length. These lengths will be sufficient for typical connection to a fuse block and chassis ground.

Connect the black wire to the negative (-) chassis ground of the vehicle. **DO NOT ATTEMPT TO INSTALL THE TRANSCEIVER IN A POSITIVE GROUND VEHICLE.** A large bolt that screws into the metallic vehicle body or chassis often provides an adequate ground if a lug is used to secure the wire to it.

Connect the red wire to the positive (+) side of the vehicle electrical system. This wire has its own in-line fuse for protection against wire penetration and transceiver defect. The connection can be made to the ignition hot so that the transceiver switches on with ignition, or it can be made to battery hot to enable the last-selected-channel of the transceiver (the transceiver must be turned off separately). Either connection is usually available in the vehicle fuse block if the red transceiver wire is terminated with an appropriate lug.

• Requirements

Both the 70-0351 and 70-0355 transceivers are designed to operate from a 12 V DC negative ground automotive electrical system. Current drain of at least 10 A should be expected. Inspection of the vehicle is recommended prior to installation. A low battery or other electrical system defects may degrade transceiver performance.

INSTALLATION

70-0351/0355

CAUTION: Check the voltage source before connecting the power cable. Too much voltage (above 16 V) can severely damage the transceiver.

Included with the trunk-mount transceiver is a 6 m power cable. The under-dash transceiver is shipped with a 2 m Power/Accessory cable. Each cable includes fused power leads for connection to vehicle electrical system. Because the transceiver chassis is connected to the negative (-) lead, **DO NOT INSTALL THE TRANSCEIVER IN A POSITIVE GROUND VEHICLE.** If the transceiver is used as a base station, the external AC-line-to-DC power supply must be adequately regulated and have sufficient current capacity.

ANTENNA

The communications system component that can affect overall performance the most is the antenna. A good quality antenna designed to provide 50 Ω terminating impedance at appropriate transceiver frequencies is recommended. When adjusting the antenna, be sure to follow its manufacturer's instructions. A better quality SWR meter should be used to accurately measure minimum reflected energy.

MICROPHONE HANGER

The hand microphone included with the transceiver has a button on its backside to mate with its hang-up clip. The clip must be mounted with three screws in a location convenient to the operator. Three 1/2" screws and three 3/4" screws, each requiring a 5/64" hole, are also provided.

An optional microphone hanger (model 70-2195) is available for use with the CTCSS option. This hang-up box may be installed in place of the microphone clip on both metallic or non-metallic surfaces.

POWER ACCESSORY PLUGS

• Under-dash

A 9-pin male Molex connector and a fused, 2 m power cable assembly, P/N 70-2211B, mates to the power/accessory connector (J415) on the rear of the 70-0351. Extra pin positions are used for con-

nection of optional devices not included with this assembly.

Optional devices can be connected to the Power/Accessory Plug by inserting Molex pins included with these devices into their respective vacant holes. See **Figure 3 - 1**. Option connections are shown in lighter shade.

• Trunk-mount

The 70-0355 has two 9-pin male Molex receptacles: J415 on the trunk unit; J324 on the Control Head. The trunk unit receptacle mates to the 70-2212B Power Cable assembly. The Power Cable includes an in-line fuse in its 6 m power leads and a jumper between pins 5 and 6 that routes speaker audio to the control head.

The 9-pin Accessory Plug connects to the rear of the control head. The speaker has Molex pins that insert into this plug. Extra pin positions are present for connection of the optional 70-2195 switching hang-up box (not included with the standard transceiver) for use with CTCSS or CDCSS. Two more pin positions are provided for optional auxiliary connections. See **Figure 3 - 2**.

EXTERNAL SPEAKER

• Under-dash (Model 70-2355)

Normally, the transceiver internal speaker is connected to receive audio by the jumper to pins 5 and 6. If one of the MIDLAND external speakers is to be utilized, the jumper must be removed to disable the internal speaker and the two wires from the external speaker must connect to pins 4 and 6.

NOTE: If the 70-2355 15 W External Speaker is to be connected, its input cable center conductor (white) must be connected to pin 6, and the shield (black) to pin 4.

• Trunk-mount

The 70-2355 15 W speaker comes with the standard trunk-mount transceiver configuration. It connects to the Control Head Accessory Plug. Its 5 1/2' cable is terminated with appropriate Molex pins for insertion into the trunk-mount Accessory Plug on the

Control Head or the under-dash Power/Accessory Plug. The speaker housing and mounting bracket assembly is 5" x 5" x 3", and the mounting surface is 4 1/4" x 1 1/4", with four 3/32" screw slots.

squelch when the microphone is lifted. The center conductor of the shielded hang-up box cable connects to pin 3, the shield to pin 2.

HANG-UP BOX

If the CTCSS feature is included in the transceiver, the optional 70-2195 Microphone Hang-Up contact/switch-box is installed to unmute CTCSS

AUXILIARY DEVICES

Pins 1 and 8 are available for auxiliary connections necessary with certain optional features. Wiring details for these are found in the literature for the option.

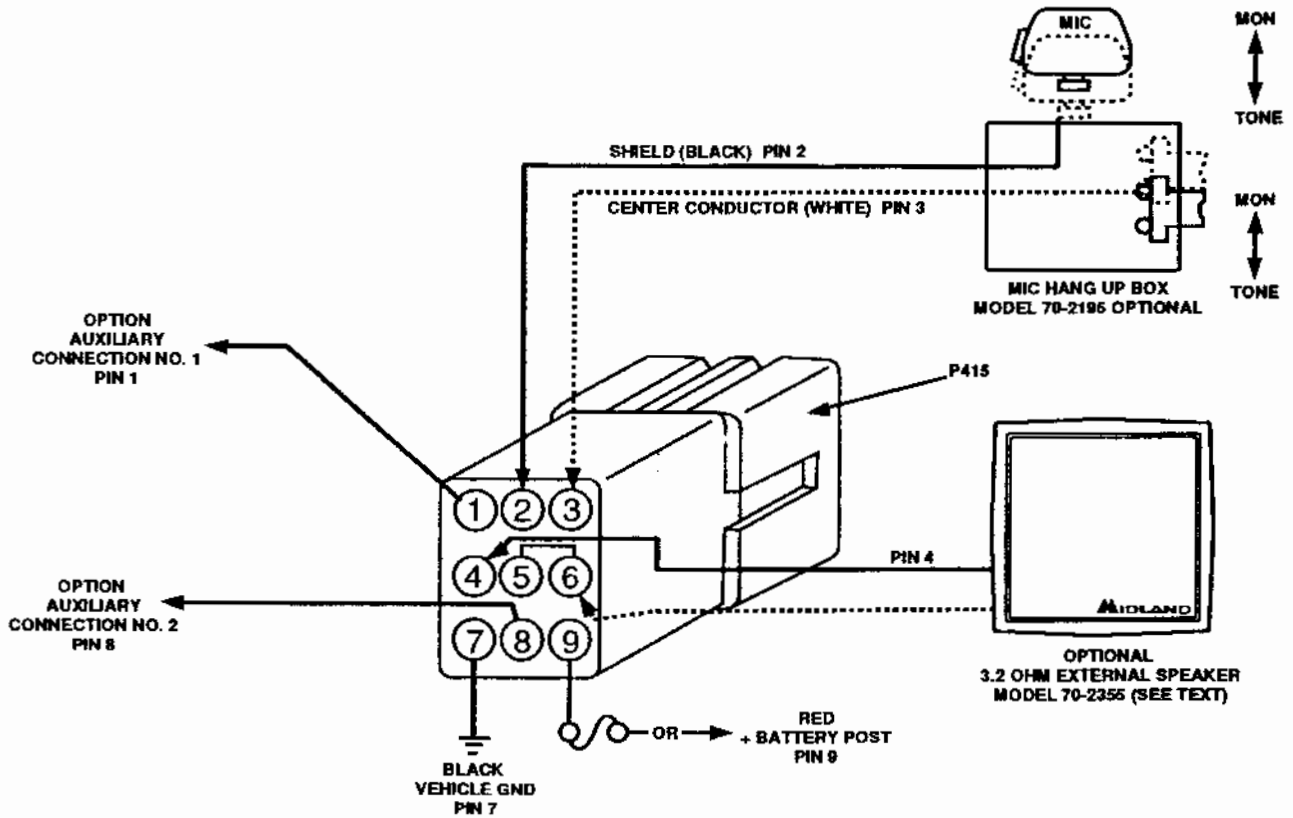

Figure 3 - 1 — Under-Dash Power/Accessory Plug

INSTALLATION

70-0351/0355

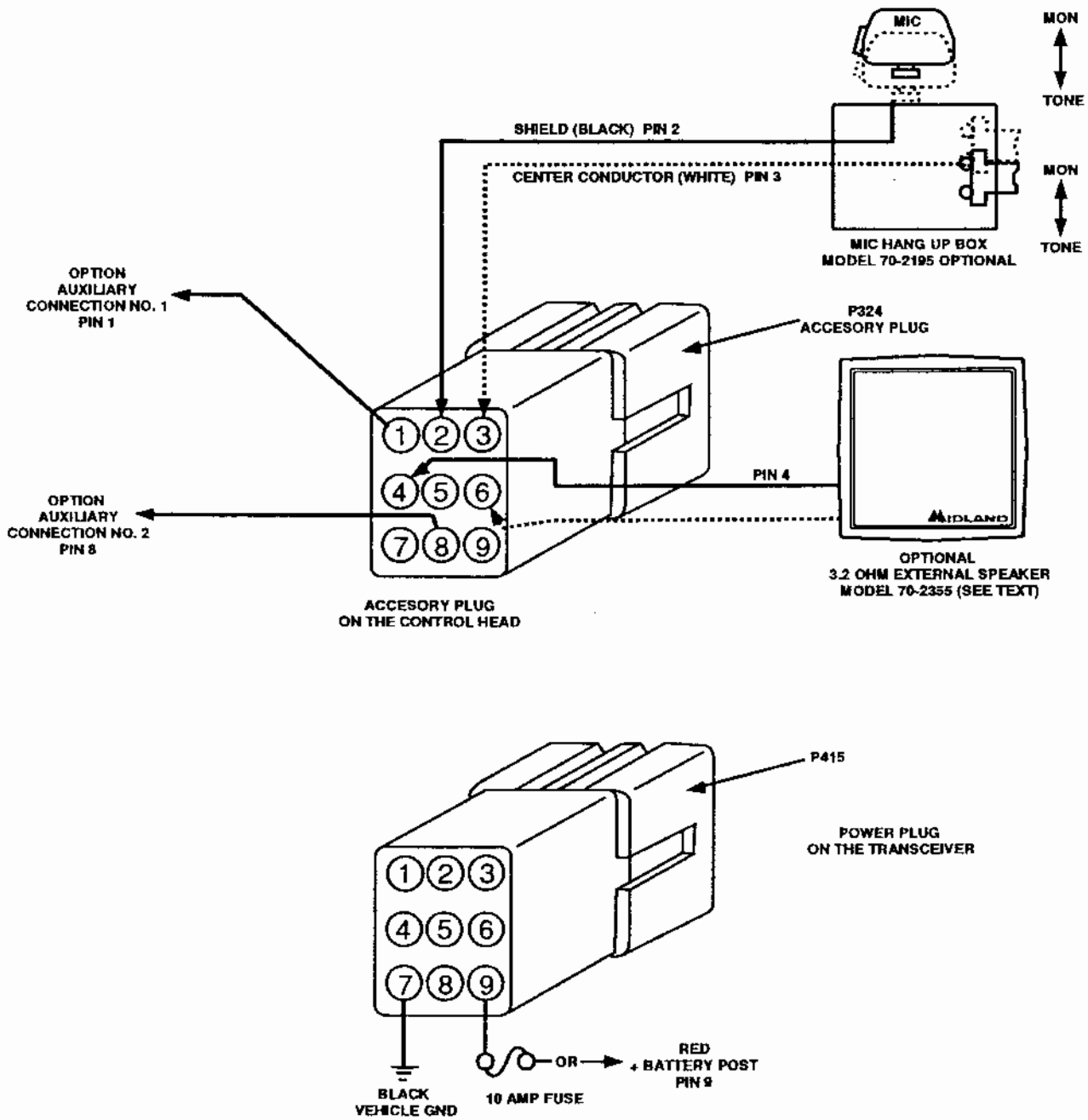

Figure 3 - 2 — Trunk-Mount Power and Accessory Plugs

SECTION 4

SERVICING

SERVICING

70-0351/0355

NOTES

REMOVING THE TR-053 BOARD

When servicing the XTR or adding option kits, you may need to remove the TR-053 Board. To do so:

1. Unscrew and remove the bottom cover.
 2. Unplug J401 and J411 (for Trunk-Mount units, unplug J414 as well).
 3. Under-Dash Units: Insert a screwdriver in the slot located on the Control Head above J411 and IC402 of the TR-053 Board (see **Figures 4 - 1a and 4 - 1b**). Pry up, then tilt the bottom part of the Control Head away from the radio chassis
- Trunk-Mount Units: Remove the two screws securing the Nose-Piece (located in the handle), and pull it off.
4. Snap off the PA Section and VCO/Reference Oscillator shield covers.
 5. Loosen the nut on Antenna Jack J501.
 6. Remove the eighteen screws securing the TR-053 Board (notice that two of the screws in the PA Section are longer than the rest).
 7. Remove the three clips holding IC401, IC402, and IC406 to the front of the radio.
 8. Lift the front part of the TR-053 Board up from the radio, and unclip Power Plug J415. Finish lifting the board out of the radio.

The TR-053 Board is now ready for servicing.

After servicing, reinstall the board by following the following steps:

9. Insert J415 through its hole and reattach it to the radio.
10. Lower the board back into the radio (make sure all wires are on top). The plate on J501 goes on the outside of the radio.
11. Insert the two long screws into their proper positions in the PA Section (see **Figures 4-1a and 4-1b**). Then insert the sixteen remaining screws.
12. Tighten the eighteen screws. Do not over-tighten.
13. Tighten the nut on J501. Check the solder connection on J501. Reflow solder if needed.
14. Replace the clips for IC401, IC402 and IC406. Replace the connector plugs into J401 and J411 (for Trunk-Mount Units, also replace the brown connector plug into J414 — notice that the white connector plug is not used).
15. Replace the cover shields for the VCO/Reference Oscillator and PA Section. Make sure that you don't clamp the wires under the covers.
16. Replace the Control Head (or Nose-Piece for Trunk-Mount Units).
17. Replace the bottom cover.

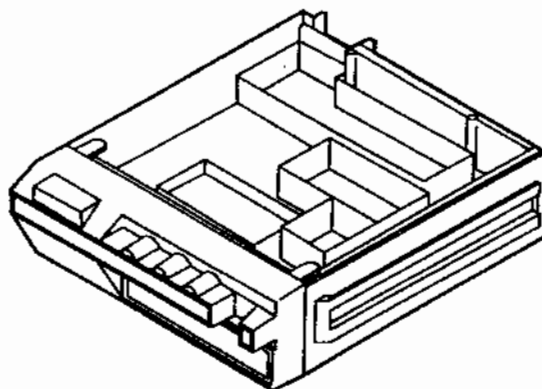

Figure 4 - 1a — SYN-TECH XTR Chassis and Control Head

SERVICING

70-0351/0355

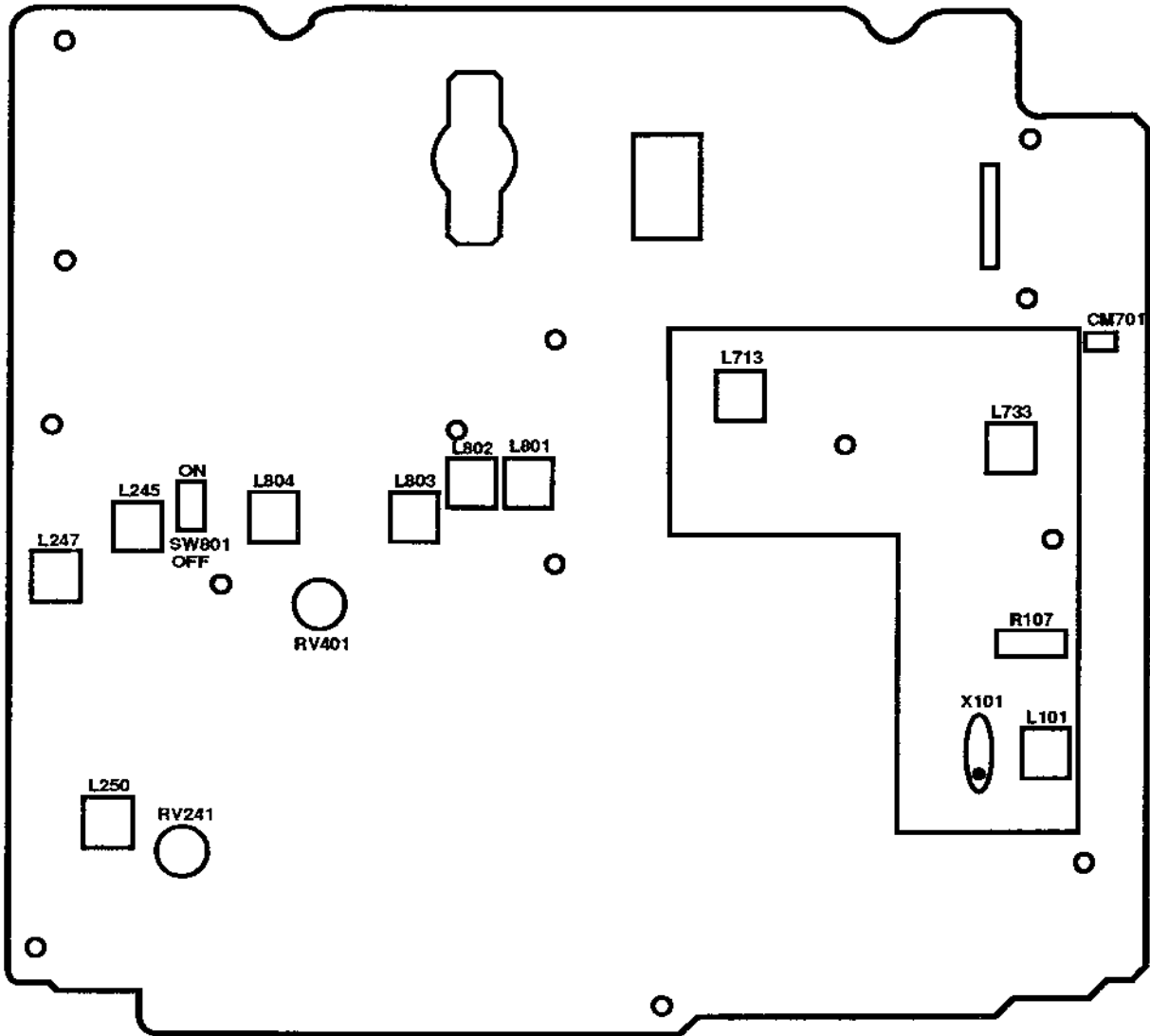
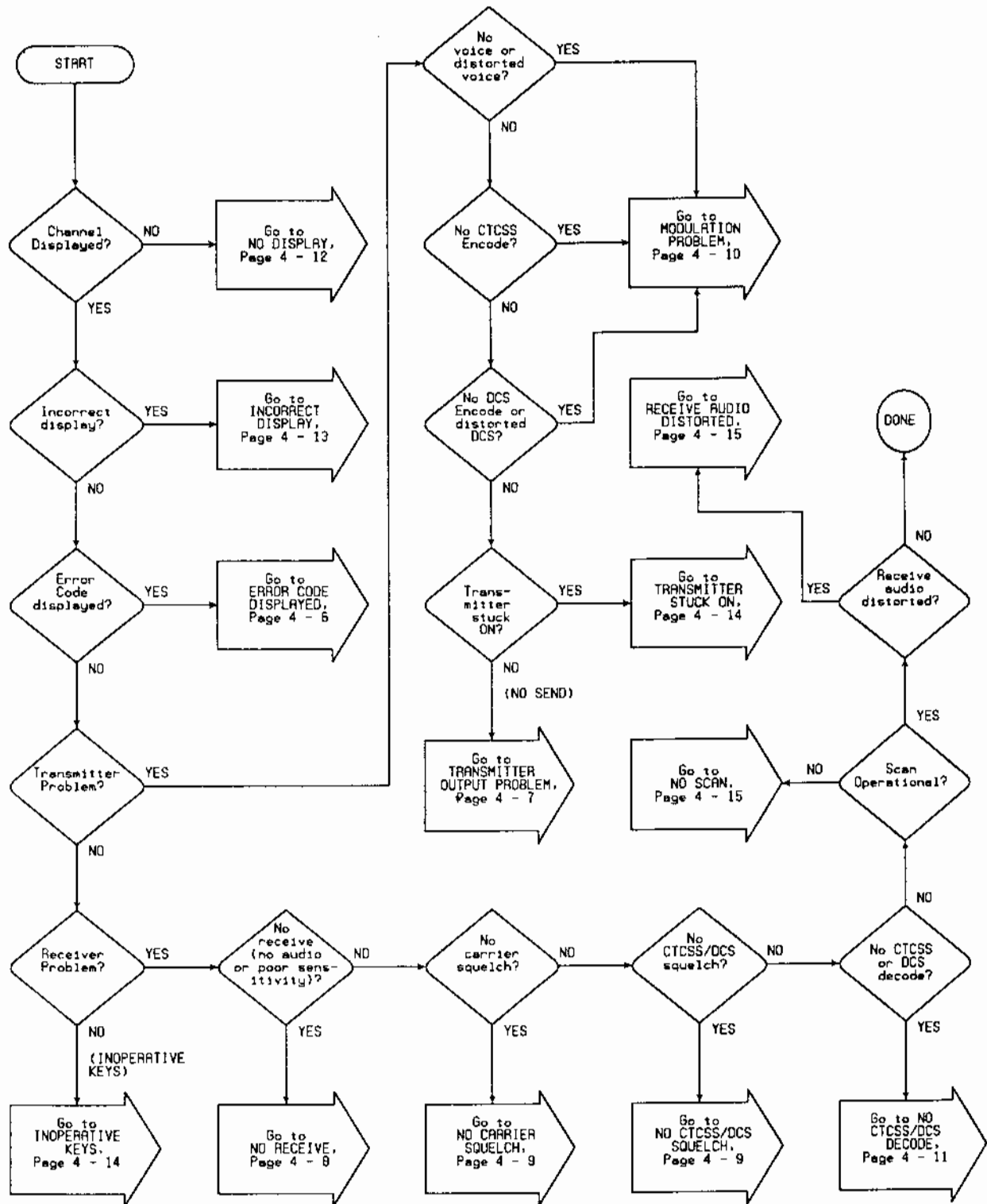
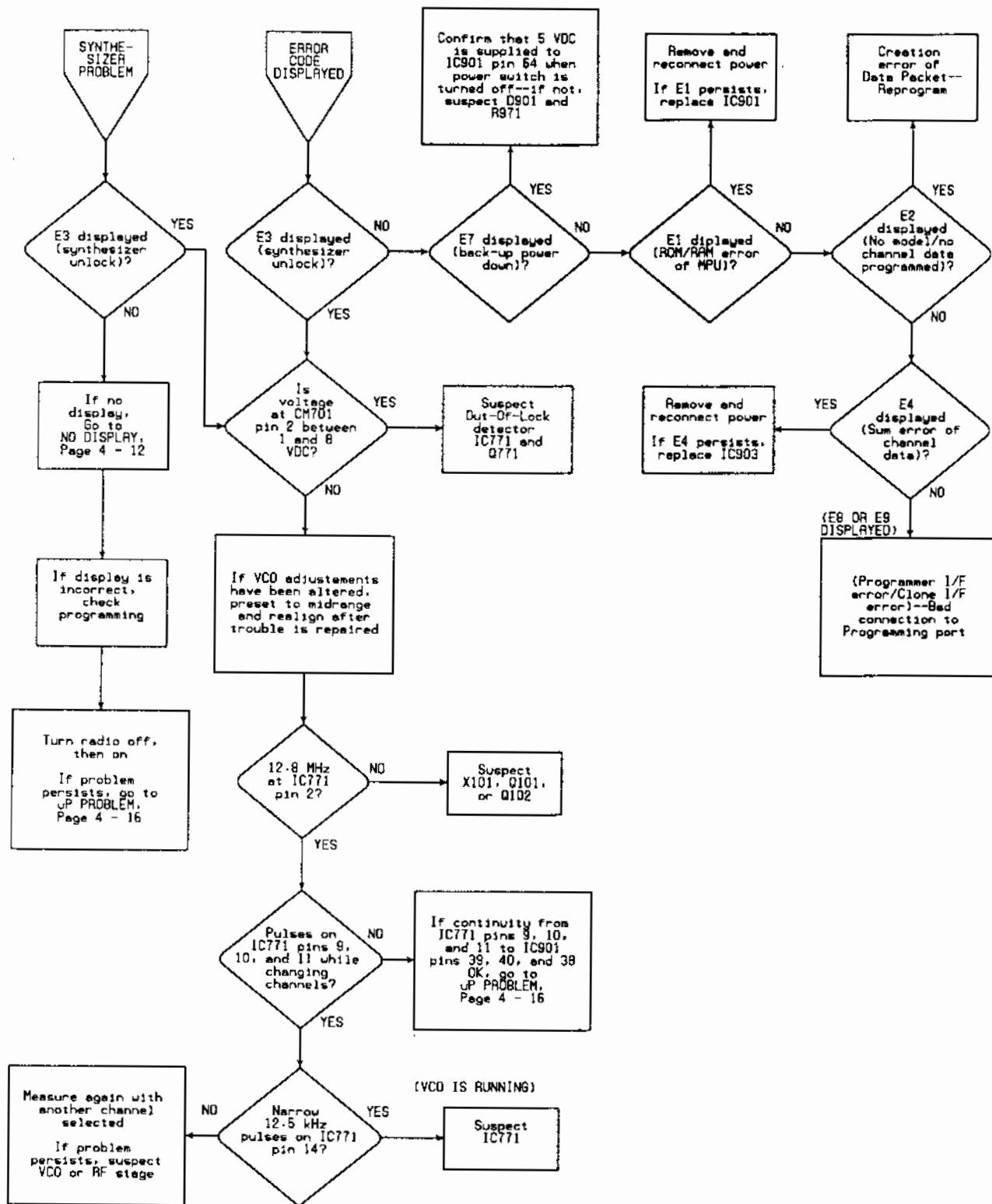

Figure 4 - 1b — TR-053 Board

TROUBLESHOOTING CHARTS



Troubleshooting Chart 4 - 1 — Getting Started



Troubleshooting Chart 4 - 2 — Synthesizer Problem/Error Code Displayed

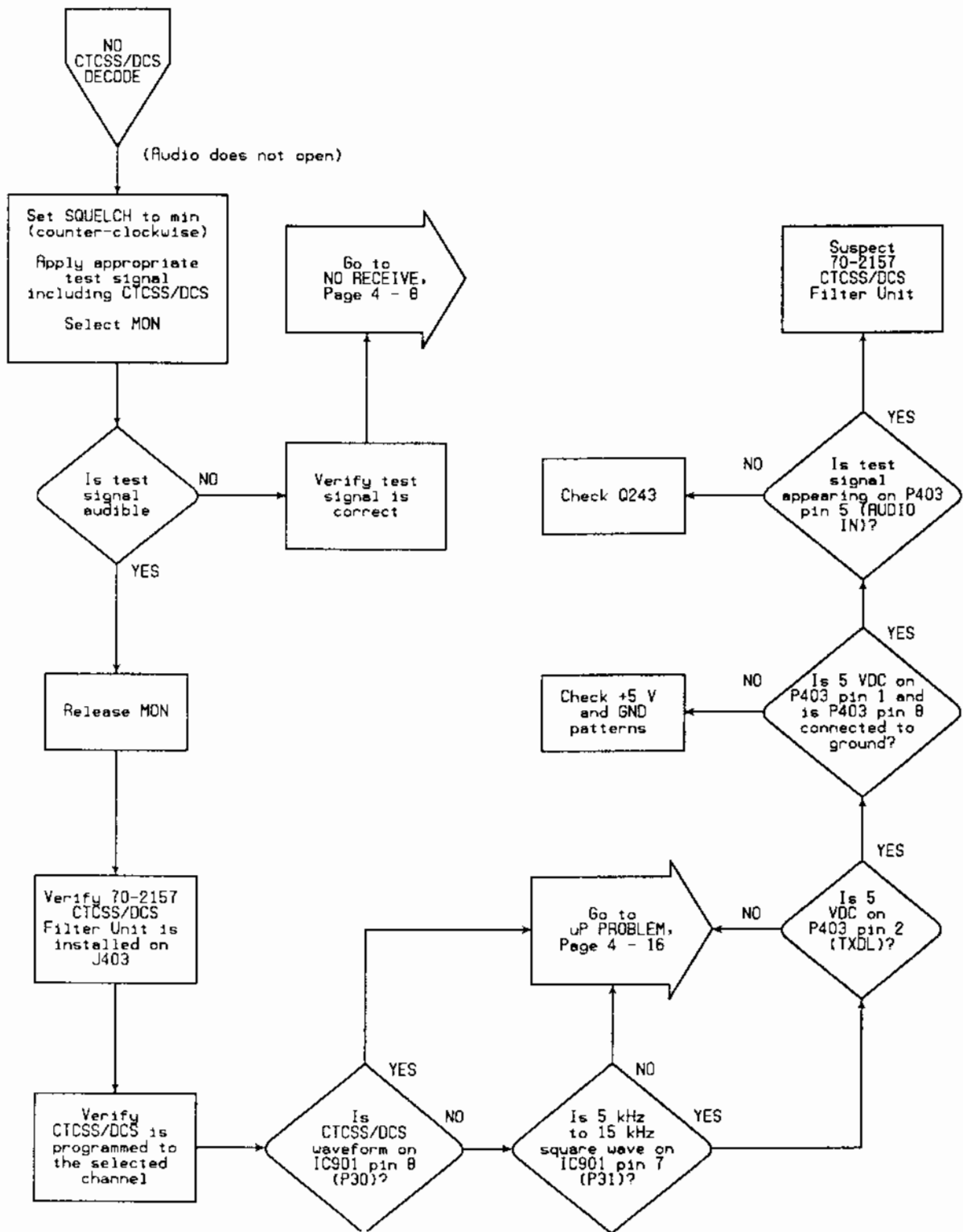

4

Troubleshooting Chart 4 - 7 — No CTCSS/DCS Decode

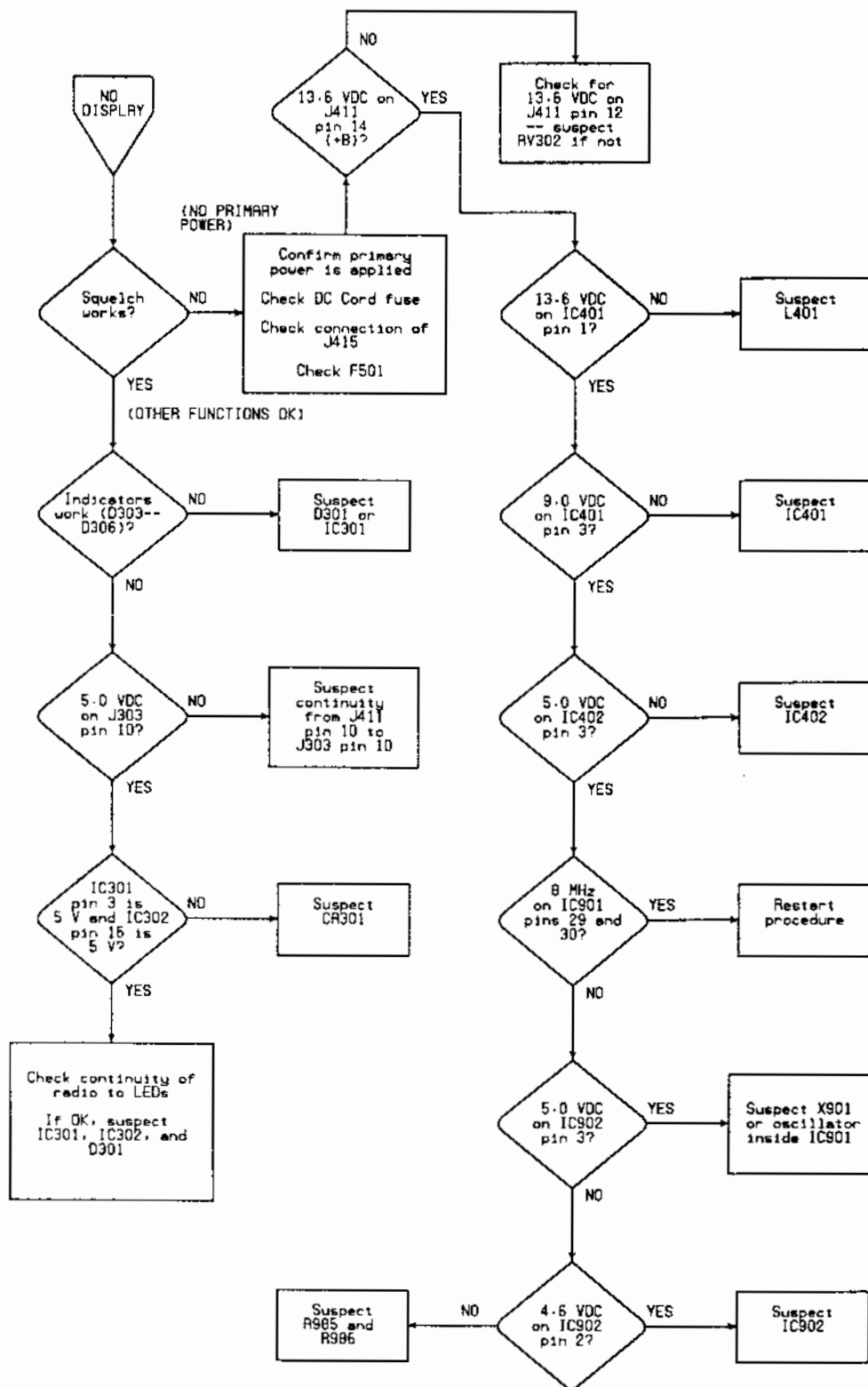

Troubleshooting Chart 4 - 8 — No Display

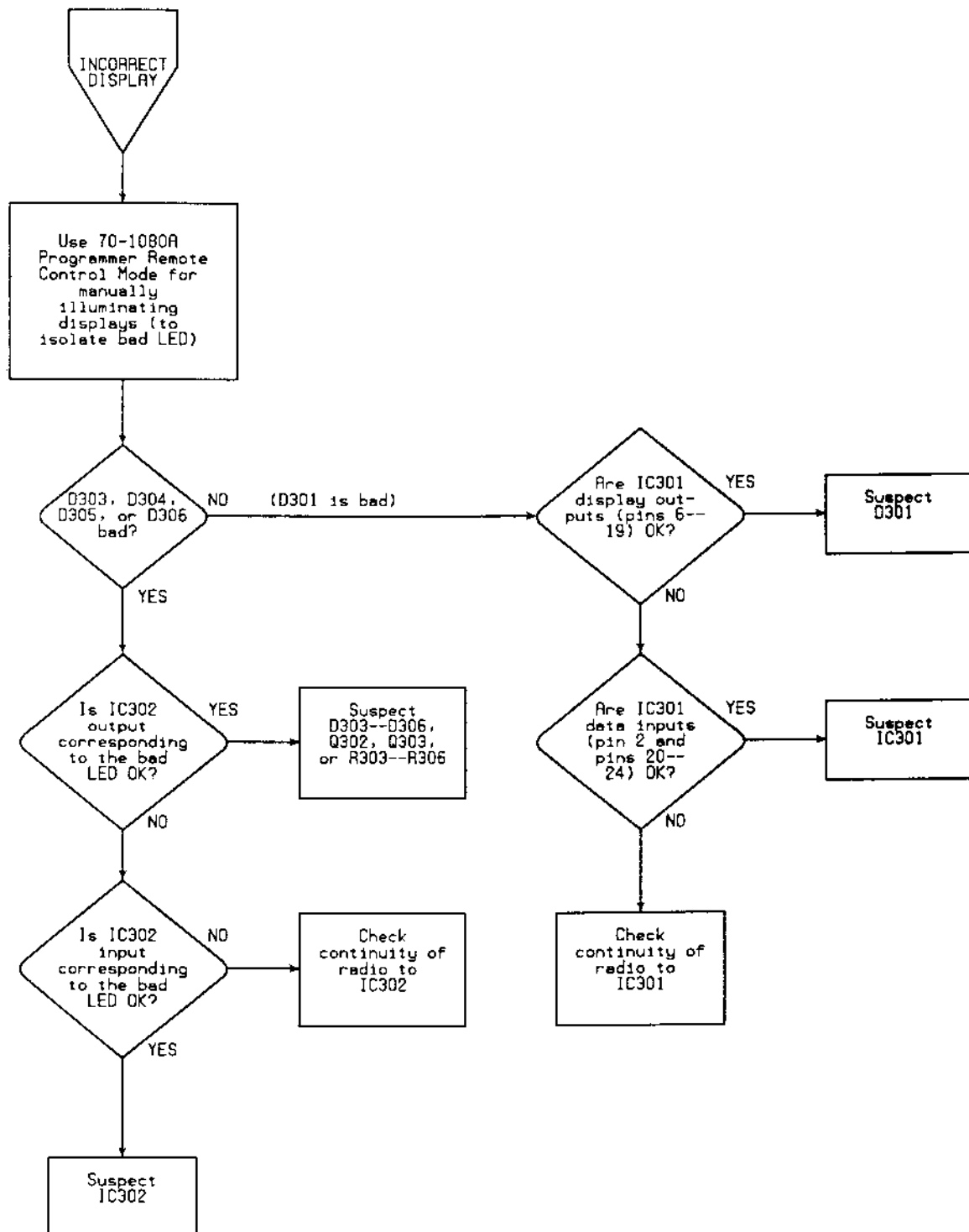

4

Troubleshooting Chart 4 - 9 — Incorrect Display

SERVICING

70-0351/0355

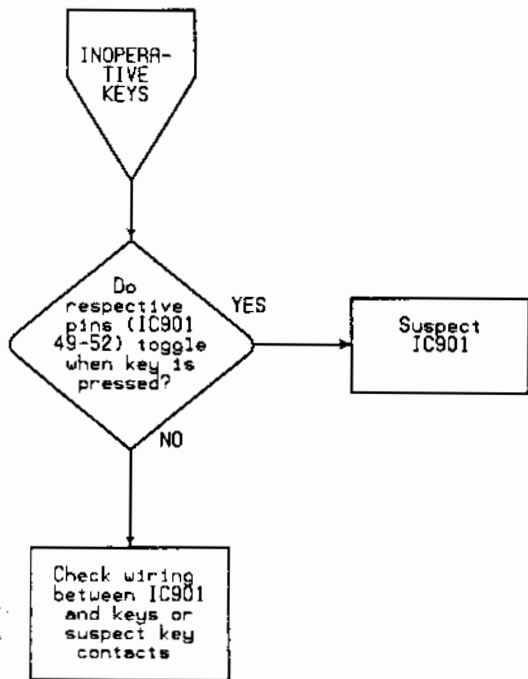

Troubleshooting Chart 4 - 10 — Inoperative Keys

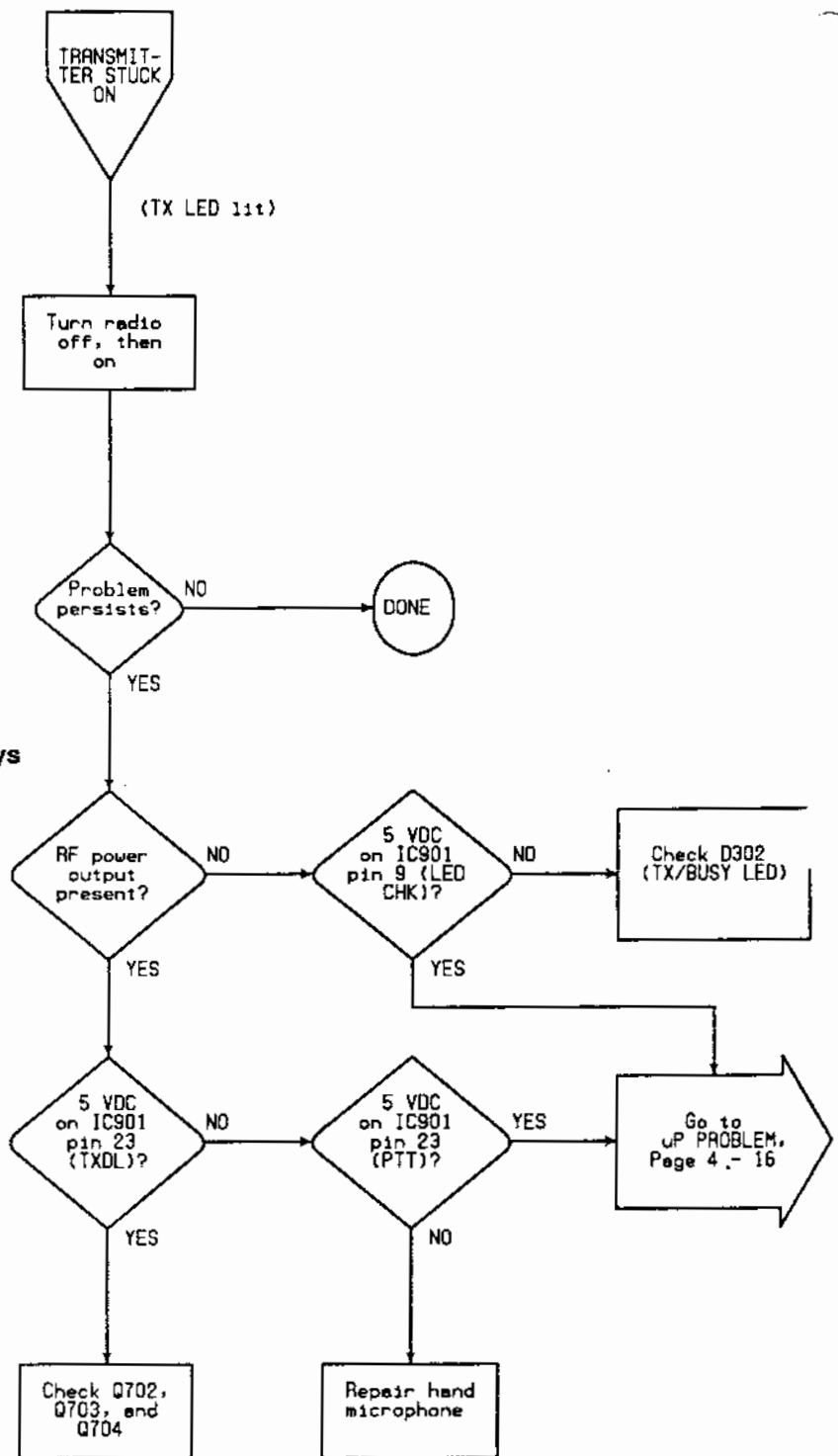

Troubleshooting Chart 4 - 11 — Transmitter Stuck On

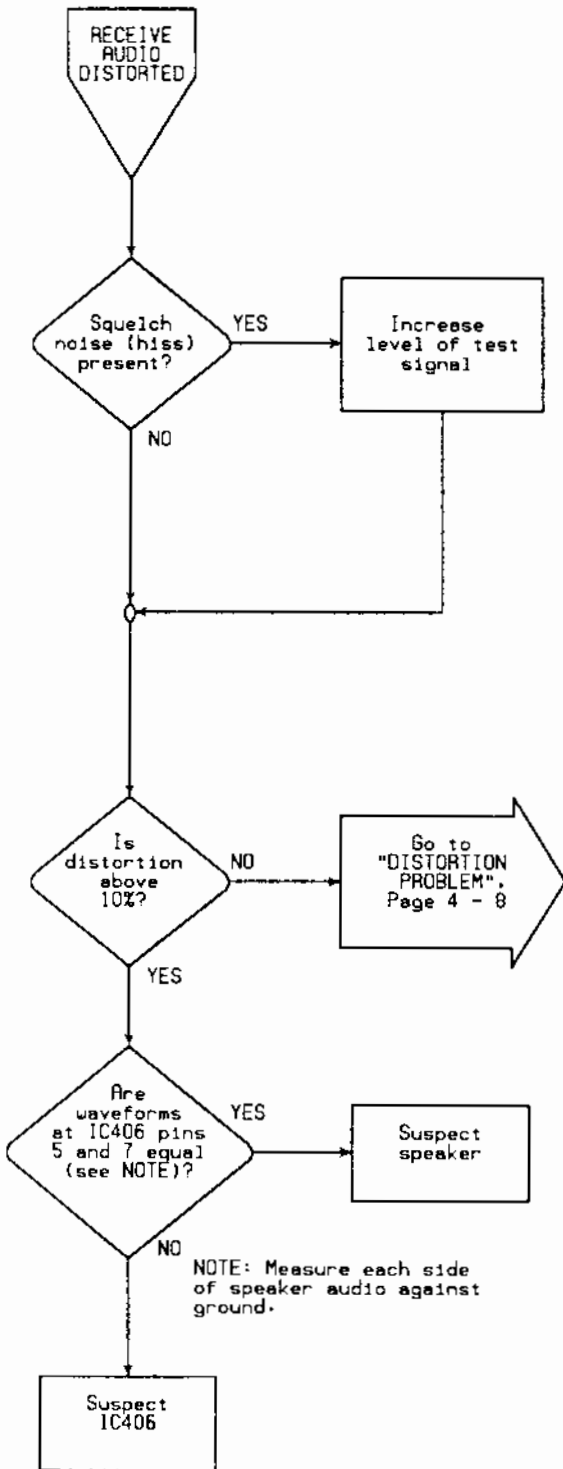

Troubleshooting Chart 4 - 12 — Receive Audio Distorted

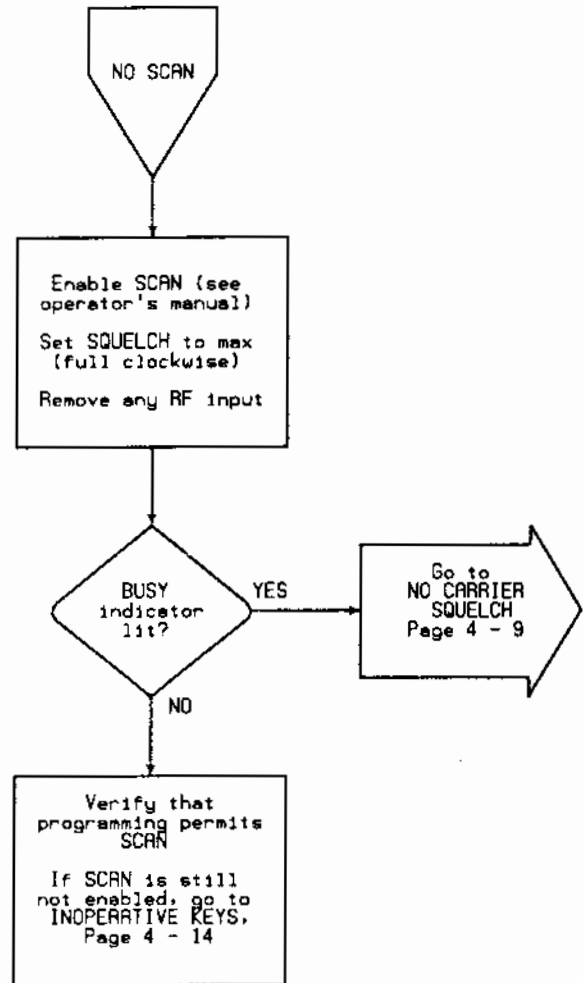

Troubleshooting Chart 4 - 13 — No Scan

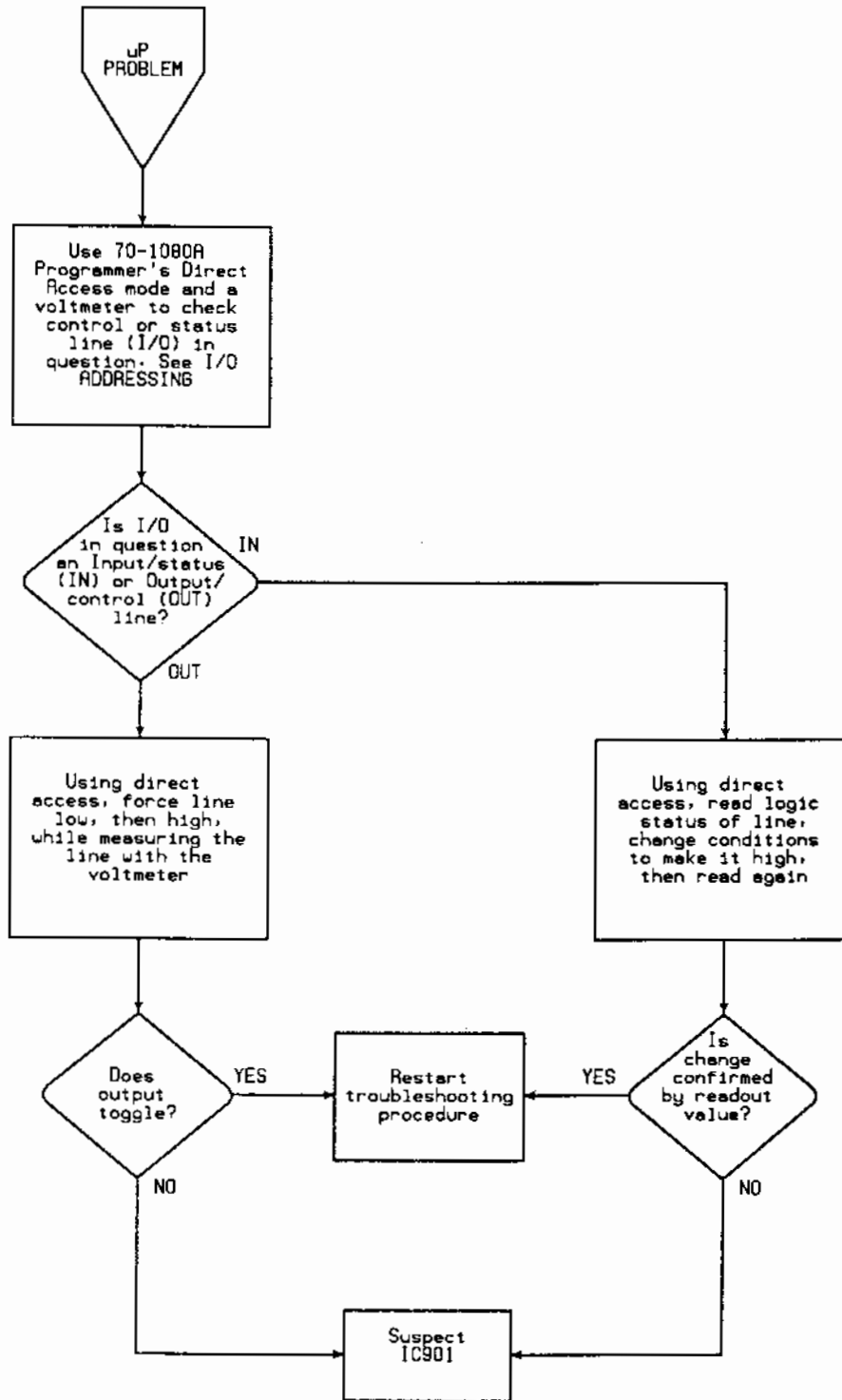

Troubleshooting Chart 4 - 14 — Microprocessor Problem

COMPONENT REPLACEMENT

STATIC POTENTIALS

Many of the transceiver components are susceptible to higher voltages whether they are in or out of a circuit. Avoid static or AC-line potentials when handling components and circuit boards. Prevent damage from electrically "hot" tips that carry AC-line or static potential by using a grounded soldering iron. The only way to alleviate risk of component damage from static discharge is to make sure all of the objects that touch the circuitry during component replacement carry the same potential. Since the soldering iron is grounded, everything else must be grounded: the bench, the equipment being worked on, and you. There usually isn't a need to wire yourself to your bench unless you work on carpeting on dry-air days. Just touch bench ground when you sit down so that you and the grounded work area are at the same potential.

REPLACING CHIP CAPACITORS AND RESISTORS

This section describes the best way to remove a chip component and install a new one. Chip components do not have leads, just metallic film on end-surfaces to solder to. Often the surface is tinned with solder. Because the metallic film can be easily damaged by contamination and excessive heat, these components must be soldered very carefully. No chip component can be unsoldered, then resoldered without damage. Always discard a used component.

• ITEMS REQUIRED:

- Grounded temperature-controlled soldering iron with a 1/32 inch flat-blade tip. The tip temperature must be maintained at approximately 600 degrees Fahrenheit.
- 60/40 electronics-grade solder, 22 gauge or thinner, with rosin flux.
- Tweezers or longnose pliers.
- Thin desoldering-wick.
- Isopropyl alcohol or Freon-TF for solvent.
- Rosin solder-flux. DO NOT USE ACID FLUX.

SERVICING

70-0351/0355

• **Procedure:**

1. Place the solder iron tip directly on the defective component to melt the glue under the component, then solder as shown in **Figure 4 - 2**. Remove the component with tweezers or longnose pliers. Discard the component.

CAUTION: Application of too much solder can create solder bridges between PC patterns under the soldered component and around the pad.

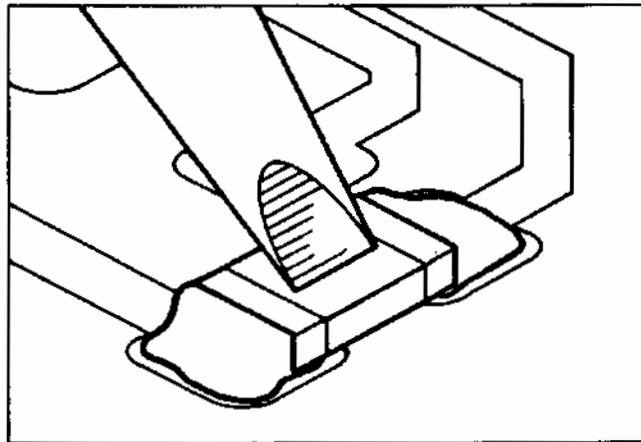

Figure 4 - 2

2. Completely remove old solder, old glue, and any other contaminants from the area with desoldering-wick and solvent.
3. Apply only enough fresh solder to coat the clean PC pad as shown in **Figure 4 - 3**.

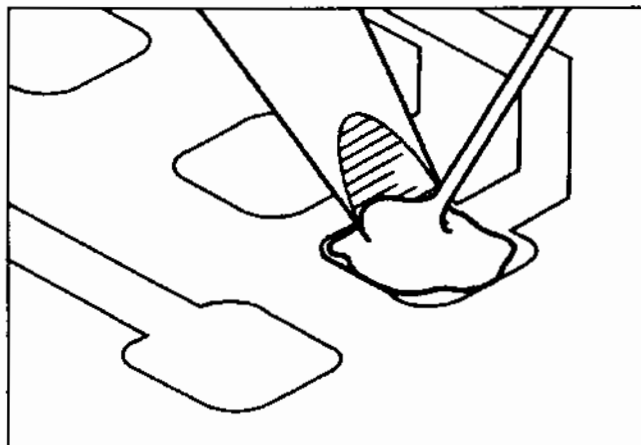

Figure 4 - 3

4. Place component and briefly heat the new solder and pad while holding the component with tweezers. Do not touch the new component with the iron. Only heated solder should touch the component to make a light 'tack' bond to it. See Figure 4 - 4.

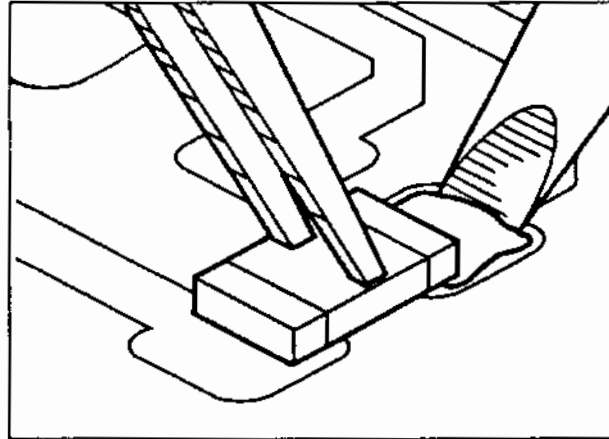

Figure 4 - 4

4

5. With one component end tacked to hold it, the other end can be soldered. Carefully apply heat to the PC pad while adding only enough fresh solder to produce a clean fillet as in Figure 4 - 5—do not apply too much solder, otherwise it may flow underneath and short the pads together. Let the hot solder flow onto the component—do not touch the component with the iron. Repeat to finish the other end of the component. Solder must adhere to all metallic end-surfaces on both ends as shown in Figure 4 - 6.

CAUTION: Avoid direct contact to the chip component with the iron tip. Too much heat and contamination will break down the metallic film on component ends resulting in loss of internal connection (a capacitor is comprised of several wafer plates that connect through the metallic end-surfaces). If satisfactory solder adhesion does not occur, the metallic end surface has been damaged and the chip component should be replaced again. More soldering will only damage the component further.

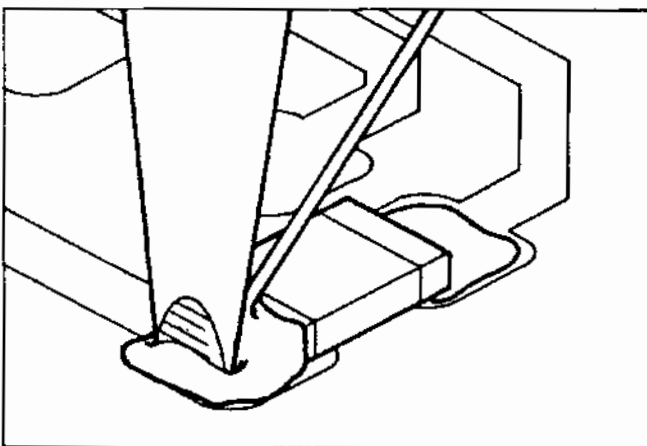

Figure 4 - 5

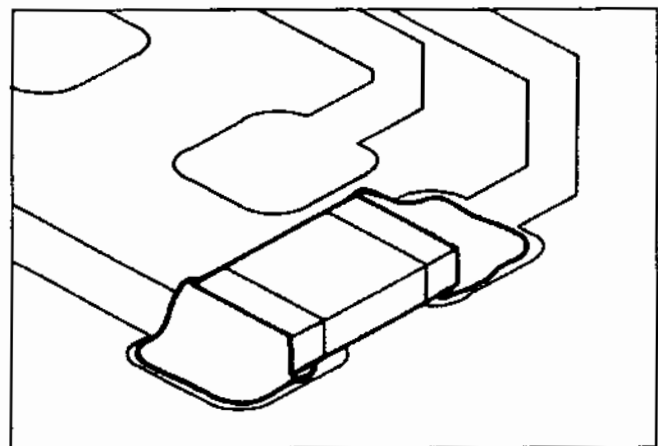

Figure 4 - 6

REPLACING COMPONENTS WITH FEED-THROUGH LEADS

Exercise extreme care when replacing components with leads that feed through a PC board. The copper plating on both sides of the printed circuit board and inside component lead holes easily separates and tears from the PC board when heated.

Use a solder suction tool or braided desoldering-wick to remove solder from component leads, one at a time. Solder must be removed carefully and thoroughly so that the IC can be pulled without resistance. After removing as much solder as possible, use a dental pick or straight-pin to break the leads loose from the inside of the cleaned-out hole. Cutting the defective components away from its leads first makes removing the leads and solder easier.

Before installing a new component, remove all solder from lead holes and make sure the device is oriented properly. Always inspect old part leads for any feed-through plating rings that may have been pulled out of holes. The plating may have completed a circuit. If so, make sure the corresponding lead of the new component is soldered to plating runners on both sides of PC board as shown below.

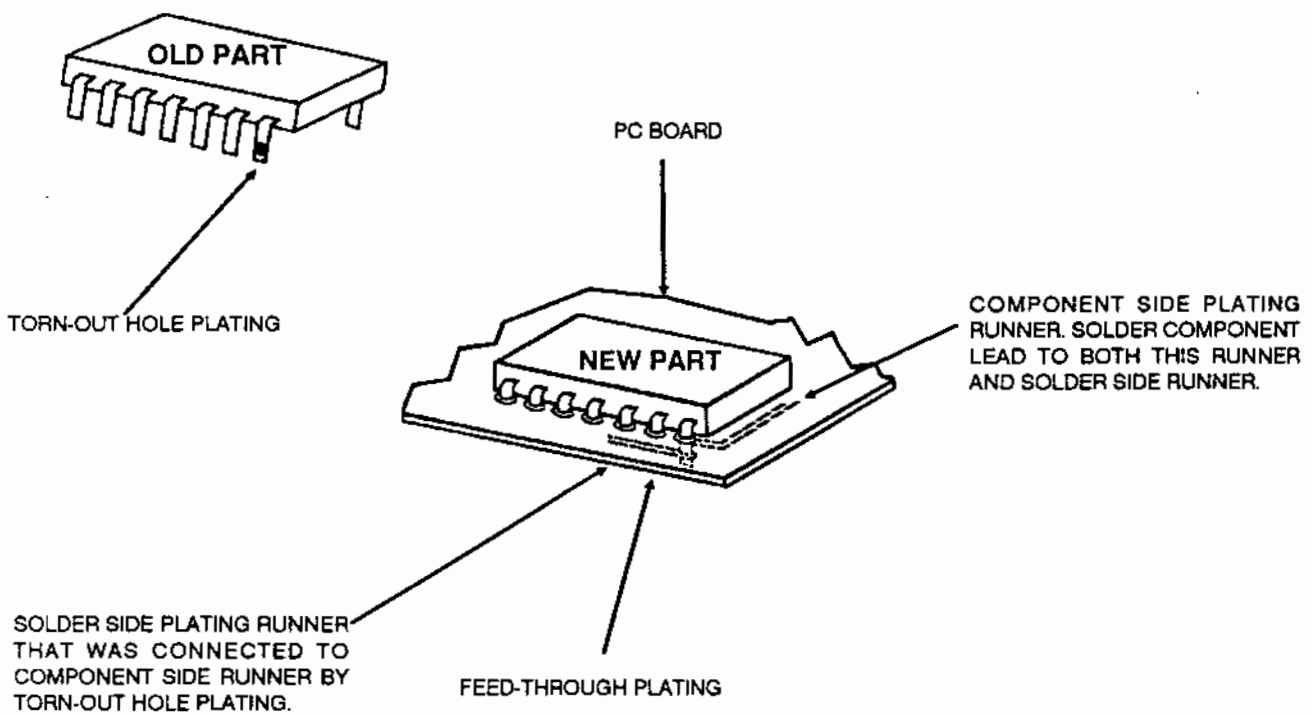

Figure 4 - 7

ELIMINATING RADIO INTERFERENCE

Occasionally, you must contend with interference from somewhere in the automobile. Interference problems are solved by understanding the interference and its path into the transceiver, locating its source logically, then eliminating it in the simplest way available.

Interference may be conducted into the transceiver directly, or induced into it, or both. Conducted interference passes through the DC power leads or the accessory wiring of the radio. Radiated interference, which can originate from anywhere in the vehicle, simply produces noise voltages on conductors inside the radio or its antenna. See **Figure 4 - 8**.

Conducted interference is simple noise voltage present in the vehicle electrical system. With many electrical devices turning on and off in a vehicle, current spikes produce voltage drops across wire resistances, causing voltage transients to appear throughout the electrical system. Connecting the radio power leads to this noisy electrical system applies the noise voltage directly to the radio. Most noise voltage is attenuated by power-line filters within the radio; but spikes that are severe enough may become audible.

While interference conducted through power leads affects only transceiver audio circuitry, induced interference often invades the receiver through the antenna by imitating receiver IF frequencies or channel frequencies. Induced interference occurs when an electromagnetic field penetrates the radio. If an electromagnetic field is strong enough, it can induce noise currents on the radio accessory and power wiring.

IDENTIFYING THE INTERFERENCE

The first step toward eliminating interference is to identify and characterize it. Listening to the noise can reveal a lot. For example: if the noise heard varies with engine speed, its source must relate to the engine, such as the alternator, ignition system, or tachometer.

Because you are dealing with frequency-modulated equipment, determining if the noise is at receiver-

sensitive frequencies is easy. With all squelch circuits open, simply apply an unmodulated signal to the transceiver that is strong enough (10 mV at the Antenna Jack) to overcome any high frequency noise signal that could invade below. If noise remains, interference is at low frequencies that can enter only by proximity coupling to radio wiring or direct conduction.

Next, power the radio with an independent 12 V power source (such as another car battery). Isolate by moving wiring and/or the radio while listening for changes in the noise level. If the noise stopped when you connected the independent power source, noise voltages are conducting through on the positive circuit or the ground (see **ELIMINATING CONDUCTED NOISE**).

ELIMINATING CONDUCTED NOISE

If noise voltage is present on the power leads, there may be defective equipment in the vehicle electrical system that needs repair. An alternator with a bad diode has a large current ripple on its output, which produces a whine in the transceiver that varies in pitch with engine speed. Its current capacity is limited, but vehicle operation will not be noticeably impaired. Lights that dim during large current demands are a good sign of such a defect.

Another possible source of conducted interference is a fan motor in the same circuit to which the radio is connected. Because a fan also induces interference, confirm that noise is conducted into the radio (see **IDENTIFYING THE INTERFERENCE**). If the interference is conducted into the DC power leads of the radio, find a power connection point in the electrical system for the transceiver that is further from the fan circuit.

Noise voltages can also be added to the radio DC power input via the ground path. This is a condition where a high, noisy current shares the ground path of the radio equipment. For example:

Ground current of a fan motor finds its way to the vehicle battery through segments of metal body A-frame assemblies (see **Figure 4 - 9**). If the elec-

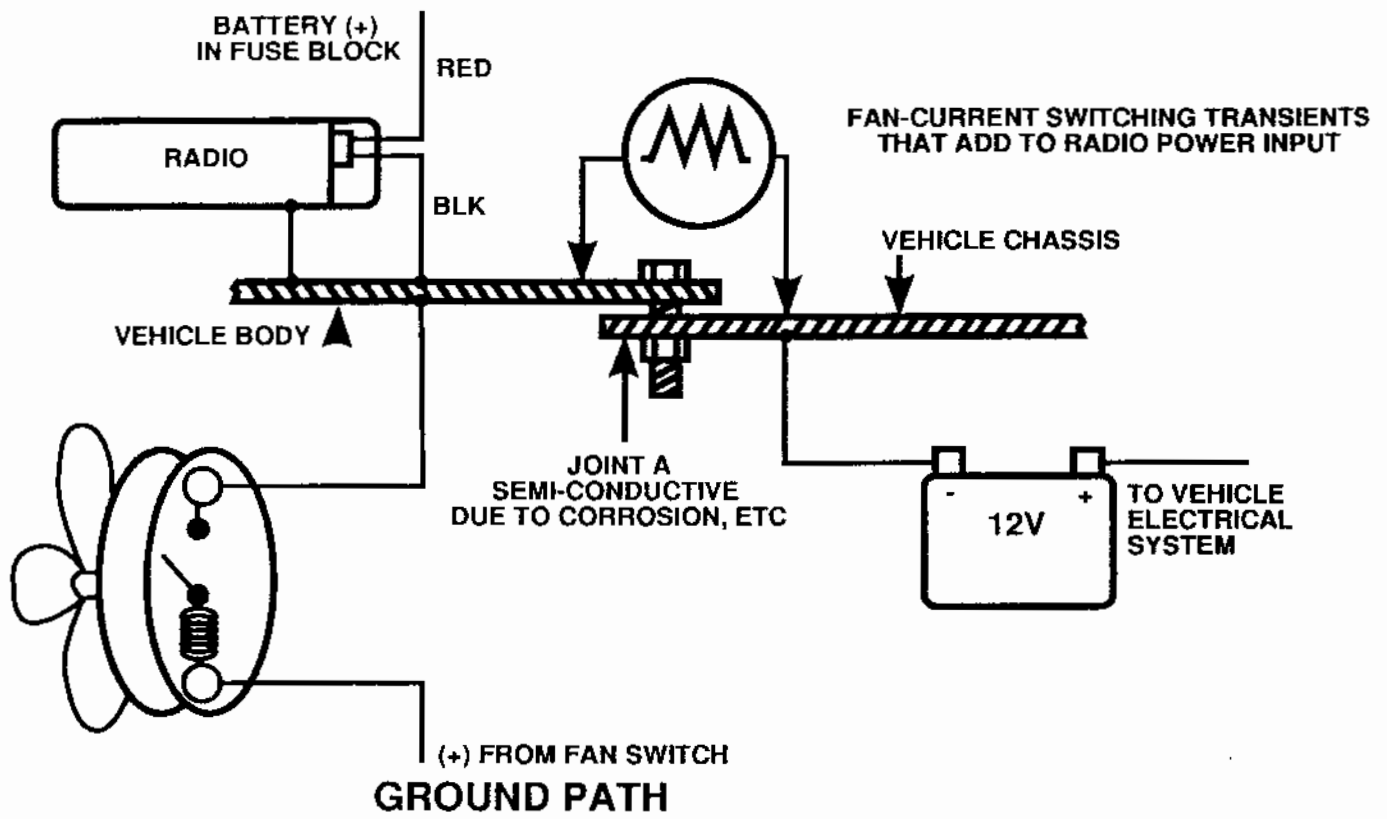

*THIS FAN MODEL EXCLUDES IT'S INDUCTANCE WHICH WOULD MAGNIFY THE ILLUSTRATED EFFECT

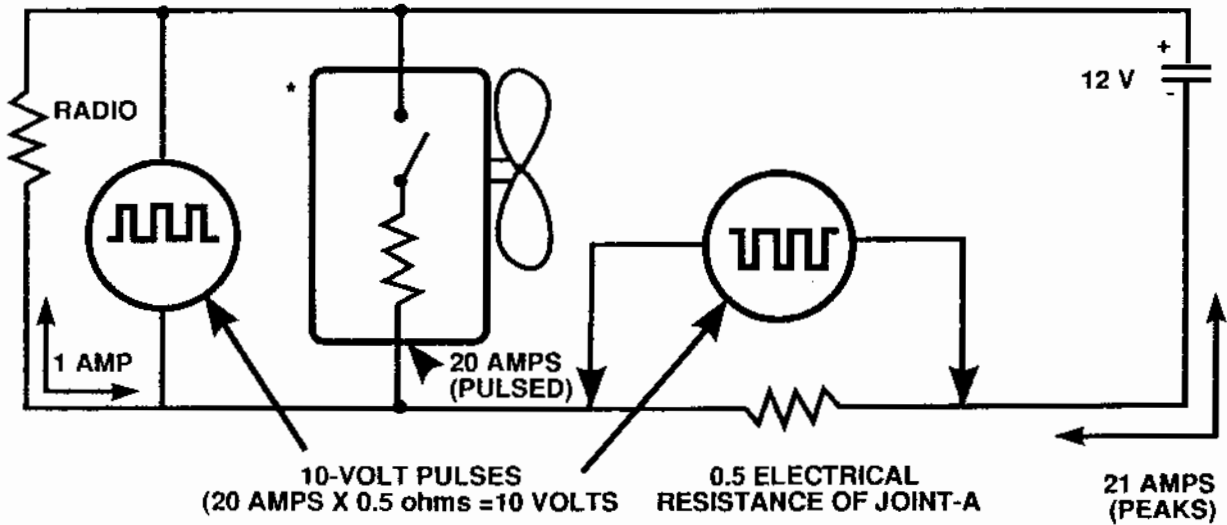

EQUIVALENT CIRCUIT

Figure 4 - 8 — Interference Paths

trical bond between two parts is weak, and the radio ground current must also travel through this weak joint, a voltage drop induced across the joint by the fan current will appear at the radio power plug.

To avoid a noisy ground, connect radio ground closer to the vehicle battery.

ELIMINATING RADIATED INTERFERENCE

If DC power source substitution proves interference is not conducted into the power leads, two likely sources of radiated interference are sparks and high frequency oscillators. Modern vehicles use many electronic accessories and systems that may produce a hash or whine in the transceiver. Oscillators within these devices, which sometimes are poorly shielded, may radiate an electromagnetic field at frequencies many multiples of the oscillator frequency.

Again, listen to the noise to learn about its source. Unless the interfering automobile accessory is part of engine operation, the noise won't vary with engine speed. The interfering accessory can be isolated by temporarily removing power to it and checking for absence of noise.

Because the lead-in wires of an automobile device can become radiating antennas, induced interference is more often radiated from the automobile accessory wiring than the accessory itself. Such interference can be inductively coupled into nearby radio power and accessory wiring or radiated toward the antenna.

Check that the radio wiring does not run next to, nor parallel with, vehicle wiring. Move the wiring to identify and/or solve this problem.

If necessary, RF chokes can be connected in series with the "hot" lead-in wires of the interfering device, close to its housing to kill the antenna effect. Usually, "hot" wires can be identified if the noise volume changes with wire movement.

Radiated interference may also enter through the antenna. This can be verified by substituting the antenna and its cable with a 50 Ω RF dummy load and short cable. The dummy load is necessary to

properly balance the receiver input and give comparable results. If the noise stops, interference was entering the antenna. The only way to solve this sort of interference problem is to eliminate radiation at the source with RF chokes as described above. Sometimes, positioning the antenna further from the interfering accessory may help.

ELIMINATING INTERFERENCE FROM SPARKS

Sparks produce electromagnetic energy over a large area of the RF spectrum. This energy usually invades the receiver input through the antenna. Therefore, the problem must be resolved at the source.

Modern vehicles use higher voltage ignition systems. As a result, electrical leakage occurs more easily through cracks and contaminants. If the interference produces a buzz while the engine is idling, and the buzz increases in pitch with engine speed, sparks are leaking to ground before distribution to the spark-plug wires. Check the ignition coil, its high voltage wire, and distributor cap for signs of arcing through cracks and burns or over dirt.

If the interference produces a repetitive popping sound while the engine is idling, and it increases in rate with engine speed, a single spark plug or wire are suspect. Check the distributor cap, spark plug wires, and spark plugs for cracks, burns, and dirt.

Spark plug and ignition coil wires in modern vehicles are made with suppressive (resistive) conductors to reduce electromagnetic radiation. This may not be the case in older vehicles. Check with an ohmmeter.

Interference from sparks made by fan motor brushes produces a whine that varies with fan speed. Badly worn brushes or bearings cause excessive sparks, and you may need to replace them. A 0.1 μ F coaxial capacitor can be connected to the positive lead as close to the motor as practical to reduce radiated interference. The capacitor body must connect securely to the grounded motor housing.

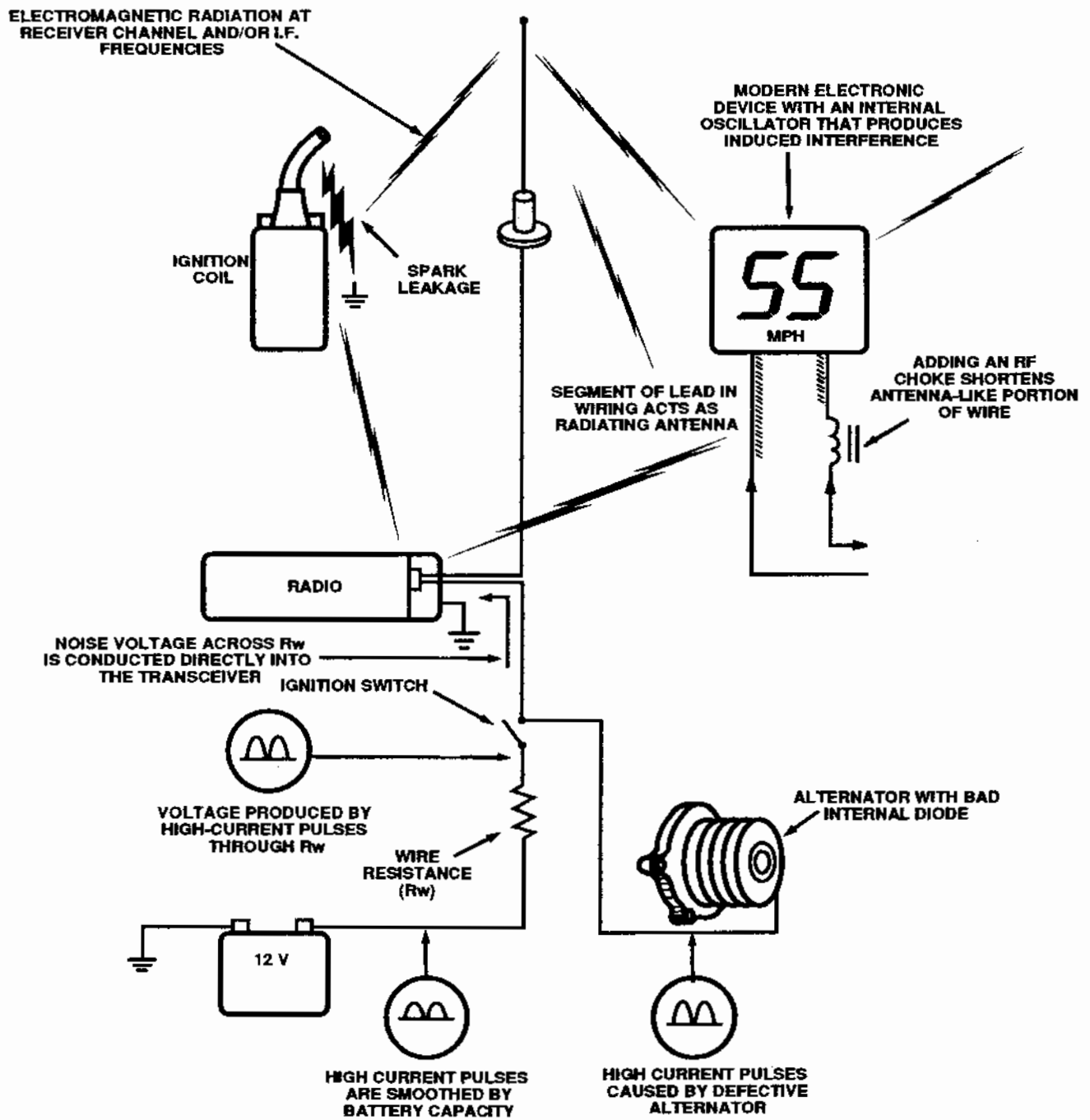

Figure 4 - 9 — A Noisy Ground

DC VOLTAGE CHARTS

Table 4 - 1 — Transistors

NAME	MODE	BASE	COLLECTOR	EMITTER
Q1	RX TX	0.7 0.0	0.0 5.0	0.0 0.0
Q2	RX	0.0-0.7	0.0-5.0	0.0
Q101	RX/TX	3.1	4.8	2.6
Q102	RX/TX	3.2	4.7	2.6
Q103	RX/TX	2.1	4.6	1.4
Q131	TX	0.9	7.6	0.7
Q201	RX	1.0	8.5	0.3
Q203	RX	0.7	6.2	0.5
Q241	RX	3.3	7.8	2.6
Q243	RX	3.1	9.1	2.2
Q244	RX	2.4	4.0	1.8
Q301	RX/TX	4.4	3.4	5.0
Q406	RX	3.6	5.0	0.0
Q409	RX/TX	8.8	8.8	8.2
Q410	RX	5.0	5.0	1.0
Q501	TX	0.8	0.0—12.2	0.0
Q502	TX	0.0	13.4	0.0
Q503	TX	0.0	13.4	0.0
Q504	TX	12.5	5.4	13.6
Q701	RX/TX	9.0	9.1	8.2
Q704	TX	8.3	8.2	9.0
Q705	RX TX	4.2 0.2	0.3 8.0	0.0 0.0
Q712	RX	1.6	7.0	0.9
Q732	TX	1.0	7.6	0.4
Q733	RX/TX	1.8	8.3	1.3
Q734	TX	1.8	8.2	1.3
Q773	RX/TX	0.0	—	0.0
Q774	RX/TX	9.0	—	9.0
Q775	RX/TX	9.0	9.0	9.0
Q776	RX/TX	0.0	0.0	0.0
Q804	RX	0.7	0.3	0.1
Q805	RX	4.7	0.1	5.3
Q806	RX	8.6	0.1	5.3
Q807	RX	0.0	8.6	0.0
Q808	RX	8.6	0.0	8.1
Q809	RX	8.4	8.4	8.9
Q810	RX	8.4	5.4	8.9
Q811	RX	5.4	8.9	4.7

Table 4 - 2 — Transistor Packs

NAME	MODE	PIN NO.					
		1	2	3	4	5	6
Q302	RX	0.0	5.0	0.0	0.0	5.0	0.0
Q303	RX	0.0	5.0	0.0	0.0	5.0	0.0
Q401	RX/TX	0.1	0.7	7.6	0.0	0.0	0.0
Q403	RX/TX	13.1	9.1	6.4	0.0	5.0	0.0-4.3
Q702	RX	7.6	0.0	0.0	0.0	0.0	8.2
	TX	7.6	0.0	7.5	7.5	8.0	8.2
Q703	RX	0.0	0.0	0.0	9.0	4.6	0.0
	TX	2.9	2.9	0.0	0.0	0.2	0.0
Q771	RX/TX	4.6	4.6	4.6	4.6	4.6	0.0
Q772	RX/TX	0.0	4.6	4.6	9.0	4.6	0.0
Q778	RX/TX	4.6	4.6	0.0	0.0	0.0	0.0

Table 4 - 3 — FET's

NAME	MODE	GATE 1	GATE 2	DRAIN	SOURCE
Q242	RX	0.0	—	9.0	0.52
Q408	SQ OPEN	4.7	—	5.0	5.0
	SQ CLOSED	0.0	—	5.0	5.0
Q711	RX	3.4	4.7	7.8	3.0
Q731	TX	3.4	4.7	7.8	3.0
Q801	RX	3.7	—	3.7	3.7
Q802	RX	3.7	—	3.7	3.7
Q803	RX	3.7	6.7	8.9	3.5

Table 4 - 4 — Integrated Circuits, 8 Pins or Less

NAME	MODE	PIN NO.							
		1	2	3	4	5	6	7	8
IC401	RX/TX	13.5	0.0	9.1	—	—	—	—	—
IC402	RX/TX	13.5	0.0	5.0	—	—	—	—	—
IC405	RX/TX	0.9	2.8	2.8	0.0	4.1	4.1	3.3	9.0
IC406	RX	6.5	6.5	6.4	0.0	6.0	13.5	6.5	—
IC408	TX	4.0	0.0	8.3	0.0	1.3	9.1	3.6	—
IC409	RX	4.0	0.0	—	0.0	1.3	9.1	3.6	—
IC412	TX	2.3	0.0	2.5	5.0	—	—	—	—
IC801	RX	8.9	8.9	0.0	2.83	4.5	2.8	0.0	8.9
IC902	RX/TX	4.9	4.9	0.0	—	—	—	—	—
IC903	RX/TX	0.0	0.0	0.0	8.2	—	1.2	9.1	3.6

Table 4 - 5 —Integrated Circuits, 13 to 16 Pins

NAME	MODE	PIN NO.							
		1	2	3	4	5	6	7	8
IC1	RX/TX	—	—	—	2.3	2.3	2.3	2.3	2.2
IC2	TX	—	—	—	—	5.0	0.0	0.0	2.3
	RX	—	—	—	—	0.0	5.0	0.0	2.3
IC50	RX/TX	1.7	1.7	1.7	5.0	1.7	1.7	1.7	1.7
IC241	SQ OPEN	6.7	6.6	6.6	6.8	6.4	6.4	6.4	6.8
	SQ CLOSED	6.7	6.0	6.6	6.8	6.4	6.4	6.4	6.8
IC301	RX/TX	0.0	—	5.0	—	—	—	—	—
IC302	RX/TX	—	—	—	—	—	—	—	0.0
IC404	RX/TX	4.7	8.5	9.1	0.0	0.1	4.8	0.0	0.0
IC411	RX/TX	4.7	4.7	4.7	9.0	4.7	4.7	4.7	4.7
IC771	RX/TX	2.3	2.3	4.7	4.7	4.6	0.0	4.7	3.2
IC772	RX/TX	0.7	0.7	0.7	0.7	9.0	9.0	0.0	0.7

NAME	MODE	PIN NO.							
		9	10	11	12	13	14	15	16
IC1	RX/TX	—	0.0	—	0.0	2.3	—	—	—
IC2	TX	2.3	2.3	2.3	5.0	0.0	5.0	—	—
	RX	2.3	2.3	2.3	0.0	5.0	5.0	—	—
IC50	RX/TX	1.7	1.7	0.0	1.7	1.7	—	—	—
IC241	SQ OPEN	2.8	0.7	0.8	3.0	0.0	3.0	0.0	1.8
	SQ CLOSED	2.8	0.7	0.8	3.1	6.3	4.7	0.0	1.8
IC301	RX/TX	—	—	—	—	—	—	—	5.0
IC302	RX/TX	—	—	—	—	—	5.0	—	—
IC404	RX/RX	8.5	9.1	0.0	0.2	0.0	9.0	—	—
IC411	RX/TX	4.7	4.7	0.0	4.7	4.7	4.7	—	—
IC771	RX/TX	0.0	4.8	0.1	—	—	—	4.6	3.5
IC772	RX/TX	0.7	0.7	0.7	9.0	9.0	9.1	—	—

SERVICING

70-0351/0355

NOTES

SECTION 5

CIRCUIT DESCRIPTIONS

CIRCUIT DESCRIPTIONS

70-0351/0355

NOTES

The SYN-TECH XTR TX/RX unit is made up of three major sections: the RF Section, the PA Section, and the Logic Section.

RF SECTION

The RF Section consists of a frequency synthesizer, a transmit modulator, a receiver, and receive audio amplifier circuits.

SYNTHESIZER

Radio frequency signals for transmission and receiver injection are produced by voltage controlled oscillators (VCO's) in a phase-lock loop (PLL) configuration.

• Voltage Controlled Oscillator

In this radio, two VCO's are used — Q731 operates in transmit mode to generate transmit frequencies; Q711 operates in receive mode to generate receive injection frequencies. Each is buffered independently: by Q732 and Q712 respectively. Outputs of the buffers are amplified by Q131 and Q203 respectively. RF signal at receiver injection frequency ($F_c + 10.7$ MHz) is applied from the LO amplifier Q203 in the receiver circuit. RF signal from Q131 is amplified further by the PA portion.

When the frequency of the VCO output drifts away from the desired value, the loop adjusts the steering voltage to compensate. A single VCO tank is voltage-tuned by varactor diodes D711 and D731 respectively. Loop steering voltage applies reverse bias to all these varactor diodes simultaneously. As steering voltage increases, varactor diode capacitance decreases: thus, net capacitance in each tank decreases, which increases resonant frequency of the tanks.

• Loop Dividers

The amplitude of the VCO signal from Q734 collector for TX and Q733 collector for RX is sufficient to feed prescaling frequency divider involved in IC771, which applies an output pulse to once every 64 or 65 input cycles. Additional frequency division is also performed within IC771 to produce 2.5 kHz.

X101 is a temperature-compensated crystal oscillator that produces a reference frequency of exactly 12.8 MHz. The reference frequency is divided by

IC771 to produce 2.5 kHz that is compared to the down-counted 2.5 kHz sample of VCO output. Normally the loop response is slowed enough by a Lag-Lead filter to block 2.5 kHz reference noise and prevent loop correction of voice modulation during transmit. Higher active filter rolloff frequency is selected by the microcomputer system on the Logic portion when the radio changes channels or it is keyed and unkeyed, by a logic low applied to the base of Q772. This increase in loop response speeds locking time.

A connection from an intermediate point in the phase/frequency comparator in IC771 is made at pin 7. When the loop is out of lock, the down-counted VCO sample is not in phase with the 2.5 kHz reference and low going pulses appear here, which produce a logic low at pin 7. This logic low is applied to Q778 through Q771 to switch Q403-1/2 and Q504. Q504 then clamps off bias to transmit PA preamplifier Q501 to prevent emission of erratic signals generated by the uncontrolled VCO.

• Modulator

Voice signals from the hand-microphone are applied to the active filter IC411, where frequency response is pre-emphasized and splatter filtered. Gain is such that stronger signals bring the output into clipping, which limits modulation. Harmonics above the 3 kHz modulation pass-band are removed by the 2.5 kHz pi-network in IC411. Modulation signals are then adjusted by IC408 and IC404 so that modulation at limiting will produce transmitted carrier deviation of ± 5 kHz. Output of processed voice signals at IC411 pin 14 is fed to the gain control IC408, where the control voltage is fed from the D/A converter IC404, controlled by the 70-1080A programmer.

RECEIVER

• Preselector

Through the TX and RX relay, RF signals are routed to the receiver input. Signals at image frequencies

CIRCUIT DESCRIPTIONS

70-0351/0355

and frequencies far removed from the desired channel are rejected by a preselector comprised of eight top-coupled, parallel tanks: L201, L202, L203, L204, L205, L206, L207 and L208. No tuning of these tanks is required for the entire channel frequency spread (6.3 MHz for A Band, 6 MHz for B Band, and 8 MHz for C Band). Q201 provides adequate gain to overcome preselector signal losses and maximize receiver sensitivity.

• Injection

First Local Oscillator signal ($F_c + 10.7$ MHz) is synthesized by the phase-lock loop and applied to Q203. A low-pass filter is provided at the output of Q203, and this rejects extraneous synthesized signals.

• First Mixer

To maximize intermodulation immunity, a balanced configuration is used for the first-mixer stage. High injection is applied to L212-primary and preselector output is applied to its secondary center tap. Diode double balanced mixer using quad-diode D202 is employed. High injection is applied to the push-pull input of the mixer. Some of this signal appears at mixer output, but most is lost because L211 is designed to be operated at the 10.7 MHz First IF frequency.

• First IF

Mixer output is applied to Q241, which drives L245. L245 tunes to match the input impedance of 10.7 MHz crystal filter FL241 and FL242, which reject signals outside the channel bandwidth. L247 matches FL242 to Q242 where the First IF signal is amplified at least 20 dB, then applied to Second IF IC241.

• Second IF

IC241 contains all second IF circuitry, a quadrature demodulator, and threshold gate. X241 and circuitry in IC241 generates a second LO injection of 10.245 MHz. A double-balanced mixer, that cancels both input signals internally, is used so that additional tuned circuits at its output are not needed. Mixer output signal of 455 kHz (IC241 pin 3) is bandpass filtered further by FL243 and FL244, then superamplified (100+ dB) by the second IF amplifier/limiter within IC241 (at pin 5).

• Demodulation

The quadrature detector in IC241 is another double-balanced mixer to which limiter output is applied. Its second input is taken from 455 kHz tank L250. Limiter output (IC241 pin 7) is also fed to L250. Frequency deviations from carrier center will cause phase difference between the two demodulator inputs, which produces output. Thus preamplified recovered audio appears at demodulator output pin 9. C264, C265 and L251 attenuate signals above 100 kHz.

• Audio

Recovered audio from Q243 is routed to the gain control IC409 and applied to the active filter IC411. The amplification level is controlled by the gain control unit. Output of the gain controller IC409 is applied to the audio amplifier IC406. Power Amplifier IC406 amplifies the audio signal and drives the speaker.

• Squelch

Audio signals at low-pass filter L251 are routed through Squelch Range RV241, which calibrates squelch-break level when the front panel SQUELCH control is maximum. Signals at RV241 top feed a two-tank 50 kHz filter. The resulting 50 kHz signal is amplified by IC241 and Q244, then rectified by D243 to produce a DC voltage that varies inversely with received RF-carrier level. The front panel Squelch control sinks current from D243 so that the voltage can be adjusted. The DC voltage is input to a level detector within IC241 and detector output is an open collector that sinks voltages to logic low when on-channel receiver input is above the squelch threshold established by RV241. Level detector output is applied through NSQ, the interconnect to microcomputer input port P41, so that the microcomputer can take appropriate action.

• Noise Blanker

Noise generated at the output of Q241 is amplified at Q803 and then sent to IC801. IC801 controls gain of pin 8 output through Q809 to Q811 (rectifier/amplifier circuit) and fed-back to pin 5. Output of IC801 pin 1 is rectified at Q804 and given to Q805 and Q806 (one-shot multi-vibrator), which generates a blanking pulse. Q801 and Q802 switch 'IF' signal on and off by blanking pulse amplified at Q807 and Q808.

60-WATT PA SECTION

• RF Power Amplifier

A PC-board stripline is used to match the Q501 base terminal to the coax. RF impedance at the collector of Q501 is transformed by PC-board stripline to the base terminal of drive Q502 and the collector of Q502 is transformed to the base of Q503. Similarly, RF impedance at the collector of final-stage Q503 is transformed by PC stripline and T1 to match the impedance at RF-gate K501. L510—L512 and C561—C568 comprise the harmonic filter. R521 and R522 serve to drain static and other DC potentials from the antenna.

• Antenna Gate

In receive mode, Relay K501 is switched to the C544 route. The RF signal path from final amplifier Q503 is then severed.

In transmit mode, Relay K501 is switched off the C544 route. The receiver port network is detuned so that it appears as a high impedance to the antenna, and K501 switches final amplifier output to the antenna at J501.

• Automatic Power Control

T1, ahead of the harmonic filter, serves as a directional coupler. D503 rectifies a small RF sample that is developed across the thin runner, producing a DC voltage that increases with RF power traveling forward into the antenna. This power-level sensing voltage is the inverting input of the comparator IC405 pin 6. The reference voltage applied to the comparator IC405 pin 5 is fed from the D/A converter IC404 pin 4, which is controlled by the microcomputer via the 70-1080A Programmer (in alignment mode).

Output of the comparator IC405 is applied to Q504 via Q403, which is a current source that feeds primary DC, to the collector circuits of the predriver Q501. The feedback loop, from the directional coupler to Q504 via the comparator input IC405 pin 6 holds RF output power at the constant level determined by the reference voltage of IC405 pin 5, which is initially adjusted using the programmer.

LOGIC SECTION

DC POWER AND RESET

5 V DC power to all logic circuitry in the Logic portion is supplied from switched 13.6 V and is regulated by IC402. Microcomputer IC901 is powered by the 5 V drop across D903, which is sourced by IC401 9 V regulator supply.

MICROCOMPUTER

Radio operation is under control of a microcomputer system located on the Logic Board. This system is comprised of Microcomputer IC901 and 2K EEPROM IC903.

All CPU activity is performed step-by-step in time with a clock. The frequency of the clock is fixed by crystal X901. Because of the high clock speed, microcomputer activity seems instantaneous.

• Display and Switches

Rotating S305 (UP) or (DN) applies a momentary logic low to pin 56 or 55 of IC901, respectively. IC901 interprets this request as a channel change up or down and outputs the appropriate BCD display data from pin 13—pin 16 (DSP3—DSP0), which is applied to the BCD-to-Seven Segment Display driver, IC301. The channel display data is latched into IC301 by the DSP STB from pin 12 of IC901. Once latched, the appropriate channel is displayed on the channel display, D301.

Pressing S301 (MON) applies a momentary logic low to pin 50 of IC901. IC901 responds by putting CTCSS/DCS decode (if installed) in the monitor state and outputs a logic high from pin 13 (DSP3) which is latched in IC302 by the LED STB sent from pin 11. The logic high is inverted by Q302-2/2 to light the MON LED, D303.

CIRCUIT DESCRIPTIONS

70-0351/0355

Pressing optional switch S302 (PSCAN) applies a momentary logic low to pin 51 of IC901. IC901 places the radio in the PSCAN mode and indicates this by outputting a logic high from pin 16 (DSP0) which is latched into IC302 by the LED STB sent from pin 11. The logic high is inverted by Q302-1/2 to light the optional PSCAN LED, D304.

Before going into the PSCAN mode, pressing S304 (ADD/DEL) applies a momentary logic low to pin 49 of IC901. IC901 outputs to the ADD/DEL LED (D306), causing it to begin flashing, allowing the user to check the PSCAN list.

During transmit, TX 9V is present at the anode of D701, which applies a positive voltage to the anode of the TX LED, turning it on. When a signal is received, Q410 is turned on, which allows a positive voltage to be applied to the anode of the BUSY LED via D401-3/3.

• CTCSS/DCS Encode/Decode

IC901 controls CTCSS/DCS encode and decode. If the optional 70-2157 CTCSS board has been installed, during receive mode the receive audio signal is high-pass filtered at IC50 (on the 70-2157 board) to remove the CTCSS/DCS tones/codes. The CTCSS/DCS square wave is input through the Signal I/O line, pin 8 of IC901. IC901 determines if the CTCSS/DCS signal received is a valid tone/code. If it is valid, the output at pin 21 (MUTE) will go to logic high, which opens radio squelch.

In TX mode, pin 8 of IC901 will output the programmed CTCSS/DCS tone/code to the 70-2157 board, if installed. TXDL goes low, turning off Q1, which turns on IC2-2/4 and IC2-4/4, allowing the tone/code on the Signal I/O line to pass through IC1. IC1 is a programmable filter that "cleans up" CTCSS/DCS tones/codes. The generated tone is applied to Level Adjust RV1, and from there to Balance Control RV401 via C6. The signal is then sent to IC411-3/4, where it is mixed with the mic audio, and also to D102 in the reference oscillator.

• RX and TX Switching

In receive mode, TXDL (pin 33 of IC901) is at logic high. This turns Q705 on, which causes Q702-1/2 to turn on. This applies RX8V to the VCO. Also, when TXDL is high, Q703-1/2 turns on, and Q703-2/2

turns off. This turns Q702-2/2 and Q704 off, which turns TX8V and TX9V off.

In transmit mode, TXDL is at logic low. This turns Q703-1/2 off, which turns Q703-2/2 on. This turns Q702-2/2 and Q704 on, which turn TX8V and TX9V on. Also, when TXDL is low, this turns Q705 off, which causes Q702-1/2 to turn off. This turns RX8V off, and TX8V and TX9V on.

• Data Control

When the radio is turned on, the contents of EEPROM IC903 are serially clocked into IC901 so that it can set up receiver frequency, scan operation, transmit/receive hold timer, busy-channel lock-out timer, time-out-timer and reference oscillator frequency control.

When a channel is changed, or when PTT is pressed, the contents of EEPROM IC903 are sent to IC901. IC901 then uses this data to send the appropriate information for the channel selected to IC771, CTCSS/DCS circuitry, display circuitry, and any signalling options.

• Reference Oscillator Frequency Control

The resistance of thermistor R107 varies with temperature. This resistance change is converted to a voltage by IC405. Output of IC405 is sent to IC901 pin 59 (TEMP). IC901 compares this data internally with the preset crystal type and programmed offset, and outputs a compensating voltage from pin 60 (F CONT). This voltage is sent to varactor diode D101 to stabilize the frequency of the reference oscillator.

• Transmit Output Power Control

Power level data is sent from IC901 pin 40 (DATA) to IC404 (the D/A converter) and outputs a reference voltage from pin 4 as described under "Automatic Power Control" on page 5 - 5.

• Modulation Level Control

Modulation level data is sent from IC901 pin 40 (DATA) to IC404 (the D/A converter) and outputs a reference voltage from pin 2, which adjust the gain of IC408. This controls the modulation level as described under "Modulator", page 5 - 3.

Table 5-1—IC901 PINOUTS

Pin No.	Pin Name	I/O Flow	Function Label	Logic & Function
1	P37	I	PC RTS	Programmer Interface
2	P36	O	PC CTS	Programmer Interface
3	P35	O	PC RD	Programmer Interface
4	P34	I	PC SD	Programmer Interface
5	P33	I	PC CD	Programmer Interface
6	P32	O	BEEP OUT	Beep Tone Output
7	P31	O	SGNCLK	Clock Output for CTCSS/CDCSS
8	P30	I/O	SG IO	Signal I/O for CTCSS/CDCSS
9	P57	O	LEDCHK	LED Check Output
10	P56	O	LEDAUX	not used
11	P55	O	LED STB	Paralleled-Data Strobe for Indicators
12	P54	O	DSP STB	Parallel Data Strobe for Displays
13	P53	O	DSP3	Display/LED Data
14	P52	O	DSP2	Display/LED Data
15	P51	O	DSP1	Display/LED Data
16	P50	O	DSP0	Display/LED Data
17	P67	O	AUXOUT	Aux Switch Output (Low = ON)
18	P66	I	TASW	Talk-around Switch Input (Low = ON)
19	P65	O	SCRB STB	Serial Data Strobe for Voice Scrambler
20	P64	O	AUX STB	Serial Data Strobe for AUX
21	P63	O	MUTE	Low = MUTE
22	P62	I	HANGUP	Low = HANG UP
23	P61	I	PTT	Low = TX
24	P60	I	VLINT	Low = LOW VOLTAGE
25	R/W	O	---	not used
26	SYNC.	O	---	not used
27	CNV _{VSS}	I	---	GND
28	RESET	I	---	Low = MICROCOMPUTER RESET
29	X _{IN}	I	----	Crystal Oscillator, 8 MHz
30	X _{OUT}	O	----	Crystal Oscillator, 8 MHz
31	0	O	---	not used
32	V _{SS}	I	---	GND
33	P27	O	TXDL	Low = TX ACTIVATE
34	P26	O	DA STB	Serial Data Strobe for D/A Converter
35	P25	O	VCOSW	VCO Switch Signal Output
36	P24	O	LPSW	Loop Switch Signal Output
37	P23	I/O	PLCL	Synth Unlock (Low = UNLOCK)
38	P22	O	DSTB	Serial Data Strobe for Synthesizer
39	P21	O	DCLK	Clock for Serial Data
40	P20	O	CHDT	Serial Data Output
41	P17	I/O	----	not used
42	P16	I/O	ECS4	Chip Select for EEPROM 4
43	P15	I/O	ECS3	Chip Select for EEPROM 3
44	P14	I/O	ECS2	Chip Select for EEPROM 2
45	P13	I/O	ESC1	Chip Select for EEPROM 1
46	P12	O	ECLK	Clock for EEPROM
47	P11	O	EDI	Data Input into EEPROM
48	P10	I	ED0	Data Output from EEPROM
49	P07	I	AUXSW/CH0	AUX Switch (Low = ACTIVE)/CHNL NO. INPUT
50	P06	I	MONSW/CH1	Monitor Switch (Low = ACTIVE)/CHNL NO. INPUT
51	P05	I	PRISW/CH2	PRI Switch (Low = ACTIVE)/CHNL NO. INPUT
52	P04	I	SCNSW/CH3	SCAN Switch (Low = ACTIVE)/CHNL NO. INPUT
53	P03	I	DEPWRSW/CH4	DE-POWER Switch (Low = ACTIVE)/CHNL NO. INPUT
54	P02	I	---/CH5	not used/CHNL NO. INPUT
55	P01	I	DNSW/CH6	DOWN Switch (Low = ACTIVE)/CHNL NO. INPUT
56	P00	I	UPSW/CH7	UP Switch (Low = ACTIVE)/CHNL NO. INPUT
57	P42	I	VL _{TIN}	not used
58	P41	I	NSQ _{IN}	NSQ Status Input (High = RECEIVE)
59	P40	I	TMP _{TR}	Thermal Sensor Input
60	DA2	O	REFCNT	Reference Frequency Control Output
61	DA1	O	---	not used
62	VREF	I	---	Reference Voltage Input to Convert A/D
63	AVSS	I	---	GND
64	VCC	I	---	+5 V

CIRCUIT DESCRIPTIONS

70-0351/0355

NOTES

5 - 8

SECTION 6

DIAGRAMS

DIAGRAMS

70-0351/0355

NOTES

6 - 2

SECTION 7

PARTS

PARTS

70-0351/0355

NOTES

7-2

MECHANICAL PARTS

U/D = UNDER-DASH T/M = TRUNK-MOUNT		
REF NO.	DESCRIPTION	PART NO.
1	CHASSIS	70-010261
2	COVER	70-010262
3	ANT PANEL	70-010313
4	CLIP	70-150126
5	PROGRAMMER PORT PACKING	70-157358
6	T/M BRACKET	70-158323
7	T/M CAP	70-150127
9	DUST PACKING	70-157428
11	PA SHIELD CASE	70-089345
12	PA SHIELD COVER	70-089340
13	VCO SHIELD CASE	70-089341
14	VCO SHIELD COVER	70-089342
15	LOG SHIELD CASE	70-089343
16	LOG SHIELD COVER	70-089344
19	GROUND LUG	70-150181
21	T/M FRONT COVER ASSY	70-010284
22	U/D FRONT COVER ASSY	70-010289
23	U/D SPEAKER BRACKET	70-158324
24	U/D VOLUME KNOB	70-110066
25	U/D VOLUME KNOB	70-110067
26	U/D SWITCH BUTTON	70-110065
31	U/D CONTROL CASE ASSEMBLY	70-010286
32	T/M CONTROL CASE ASSEMBLY	70-010290
33	T/M CONTROL CHASSIS	70-010287
34	T/M CONTROL COVER	70-010288
35	T/M CONTROL BRACKET	70-158326
36	T/M COIN SCREW	70-150130
37	T/M FIBER WASHER	70-151363
38	T/M RUBBER WASHER	70-150135
39	T/M PCB GUIDE	70-150140
39	U/D PCB GUIDE	70-158354
40	U/D VOLUME BRACKET	70-158328
42	LED SPACER	70-150133
45	T/M HANDLE	70-158325
46	T/M HANDLE BASE	70-150132
48	T/M BRACKET ASSY	70-158326
50	U/D BRACKET ASSY	70-158327
53	WASHER	70-150150
81	INSULATOR	70-157409
86	RING	70-150148
70	CHASSIS	70-010300
71	PA COVER (H)	70-010302
72	PA PACKING	70-157398
73	SHIELD TUBE	70-157399
74	CONNECTOR COVER	70-010304
75	LOCK PLATE	70-010303
76	PCB HEAT SINK	70-089359
78	FE GROUND SPRING	70-152123
89	IF SHIELD	70-089386
101	SCREW PLAX PAN HD M3 x 10	70-150138
105	T/M SCREW SEMS PAN HD M2 x 14	70-150191
106	SCREW SEMS M3 x 10	70-150180
107	SCREW SEMS M3 x 12	70-150151
109	U/D FIXED SCREW PACK	70-000012
110	T/M FIXED SCREW PACK	70-000013
111	T/M SCREW BIND HD M3 x 8	70-150146
112	SCREW FLAT HD M3 x 8	70-150177
113	SCREW FLAT HD M3 x 10	70-150178
114	SCREW BIND HD M3 x 12	70-151839
115	SCREW BIND HD M3 x 10	70-150171
116	SEMS M3 x 8	70-150179
G01	TRX, LOGIC PCB	TR-053
G02	MIC CONNECTOR PCB	CX-90
G03	DISPLAY PCB	CX-81
G04	OPERATE PCB	CX-92
G05	T/M ADAPTOR (HANDLE) PCB	Z-593
G06	T/M ADAPTOR (SMALL REMOTE)	Z-594

7

PARTS

70-0351/0355

TR-053 BOARD

70-0351/0355 A BAND USE "A"			70-0351/0355 B BAND USE "B"			70-0351/0355 C BAND USE "C"		
REF NO.	DESCRIPTION	PART NO.	REF NO.	DESCRIPTION	PART NO.			
CAPACITORS			CAPACITORS (CONTINUED)					
C102	47 pF, 50 V, CER	70-138185	C217 A	680 pF, 50 V, CER	70-138252			
C103	1000 pF, 50 V, CER	70-138255	C217 B	680 pF, 50 V, CER	70-138252			
C104	100 pF, 50 V, CER	70-138364	C217 C	580 pF, 50 V, CER	70-138407			
C106	22 pF, 50 V, CER	70-138171	C218 A	270 pF, 50 V, CER	70-138403			
C107	27 pF, 50 V, CER	70-138185	C218 B	180 pF, 50 V, CER	70-138230			
C108	0.022 uF, 50 V, CER	70-138182	C218 C	130 pF, 50 V, CER	70-138406			
C109	1000 pF, 50 V, CER	70-138255	C219 A	750 pF, 50 V, CER	70-138405			
C110	10 pF, 50 V, CER	70-138187	C219 B	580 pF, 50 V, CER	70-138407			
C111	0.022 uF, 50 V, CER	70-138182	C219 C	470 pF, 50 V, CER	70-138404			
C112	0.022 uF, 50 V, CER	70-138182	C220 A	750 pF, 50 V, CER	70-138405			
C113	47 pF, 50 V, CER	70-138185	C220 B	390 pF, 50 V, CER	70-138363			
C114	47 pF, 50 V, CER	70-138185	C220 C	220 pF, 50 V, CER	70-138176			
C115	1000 pF, 50 V, CER	70-138255	C221 A	270 pF, 50 V, CER	70-138403			
C116	0.022 uF, 50 V, CER	70-138182	C221 B	220 pF, 50 V, CER	70-138176			
C117	120 pF, 50 V, CER	70-138303	C221 C	180 pF, 50 V, CER	70-138230			
C118	120 pF, 50 V, CER	70-138303	C222	0.01 uF, 50 V, CER	70-138270			
C119	1000 pF, 50 V, CER	70-138255	C223	0.01 uF, 50 V, CER	70-138270			
C122	1000 pF, 50 V, CER	70-138255	C224	0.01 uF, 50 V, CER	70-138270			
C124	1000 pF, 50 V, CER	70-138255	C232 A	58 pF, 50 V, CER	70-138254			
C125	10 uF, 16 V, AL, ELYC	70-138191	C232 B	47 pF, 50 V, CER	70-138185			
C131	0.022 uF, 50 V, CER	70-138182	C232 C	33 pF, 50 V, CER	70-138188			
C132	4700 pF, 50 V, CER	70-138183	C233	4700 pF, 50 V, CER	70-138183			
C134	100 pF, 50 V, CER	70-138175	C235	100 pF, 50 V, CER	70-138175			
C136 A	220 pF, 50 V, CER	70-138349	C237 A	39 pF, 50 V, CER	70-138233			
C136 B	150 pF, 50 V, CER	70-138231	C237 B	33 pF, 50 V, CER	70-138186			
C136 C	100 pF, 50 V, CER	70-138175	C237 C	22 pF, 50 V, CER	70-138171			
C137	100 pF, 50 V, CER	70-138175	C238	100 pF, 50 V, CER	70-138175			
C138 A	100 pF, 50 V, CER	70-138175	C239	0.022 uF, 50 V, CER	70-138182			
C138 B	68 pF, 50 V, CER	70-138229	C241	580 pF, 50 V, CER	70-138407			
C138 C	100 pF, 50 V, CER	70-138175	C242	82 pF, 50 V, CER	70-138250			
C201 A	270 pF, 50 V, CER	70-138403	C243	270 pF, 50 V, CER	70-138403			
C201 B	180 pF, 50 V, CER	70-138230	C244	82 pF, 50 V, CER	70-138250			
C201 C	150 pF, 50 V, CER	70-138231	C245	22 pF, 50 V, CER	70-138171			
C202 A	750 pF, 50 V, CER	70-138405	C246	0.022 uF, 50 V, CER	70-138182			
C202 B	470 pF, 50 V, CER	70-138404	C247	0.022 uF, 50 V, CER	70-138182			
C202 C	270 pF, 50 V, CER	70-138403	C248	0.022 uF, 50 V, CER	70-138182			
C203 A	680 pF, 50 V, CER	70-138252	C249	0.022 uF, 50 V, CER	70-138182			
C203 B	470 pF, 50 V, CER	70-138404	C250	150 pF, 50 V, CER	70-138231			
C203 C	390 pF, 50 V, CER	70-138363	C251	330 pF, 50 V, CER	70-138228			
C204 A	100 pF, 50 V, CER	70-138175	C252	7 pF, 50 V, CER	70-138181			
C204 B	130 pF, 50 V, CER	70-138406	C253	88 pF, 50 V, CER	70-138228			
C204 C	100 pF, 50 V, CER	70-138175	C254	0.022 uF, 50 V, CER	70-138182			
C205 A	33 pF, 50 V, CER	70-138188	C255	47 pF, 50 V, CER	70-138185			
C205 B	22 pF, 50 V, CER	70-138171	C256	100 pF, 50 V, CER	70-138175			
C205 C	15 pF, 50 V, CER	70-138205	C257	22 pF, 50 V, CER	70-138171			
C206 A	100 pF, 50 V, CER	70-138175	C258	0.1 uF, 25 V, CER	70-138327			
C206 B	130 pF, 50 V, CER	70-138406	C259	0.1 uF, 25 V, CER	70-138327			
C206 C	100 pF, 50 V, CER	70-138175	C260	0.01 pF, 50 V, CER	70-138270			
C207 A	680 pF, 50 V, CER	70-138252	C261	0.022 uF, 50 V, CER	70-138182			
C207 B	470 pF, 50 V, CER	70-138404	C262	0.022 uF, 50 V, CER	70-138182			
C207 C	390 pF, 50 V, CER	70-138363	C263	120 uF, 16 V, AL, ELYC	70-135167			
C208 A	820 pF, 50 V, CER	70-138406	C264	0.022 uF, 50 V, CER	70-138182			
C208 B	580 pF, 50 V, CER	70-138407	C265	4700 pF, 50 V, CER	70-138183			
C208 C	470 pF, 50 V, CER	70-138404	C266	0.022 uF, 50 V, CER	70-138182			
C209 A	270 pF, 50 V, CER	70-138403	C267	0.022 uF, 50 V, CER	70-138182			
C209 B	180 pF, 50 V, CER	70-138230	C268	6800 pF, 50 V, CER	70-138173			
C209 C	120 pF, 50 V, CER	70-138303	C269	2200 pF, 50 V, CER	70-138235			
C210	0.01 uF, 50 V, CER	70-138270	C270	6800 pF, 50 V, CER	70-138173			
C212 A	68 pF, 50 V, CER	70-138228	C271	4700 pF, 50 V, CER	70-138183			
C212 B	0.01 uF, 50 V, CER	70-138270	C272	1000 pF, 50 V, CER	70-138255			
C212 C	0.01 uF, 50 V, CER	70-138270	C273	0.047 uF, 16 V, CER	70-138408			
C213 A	270 pF, 50 V, CER	70-138403	C274	4700 pF, 50 V, CER	70-138183			
C213 B	220 pF, 50 V, CER	70-138178	C275	1 uF, 35 V, TA, ELYC	70-138087			
C213 C	180 pF, 50 V, CER	70-138230	C276	0.022 pF, 50 V, CER	70-138182			
C214 A	750 pF, 50 V, CER	70-138405	C277	1000 pF, 50 V, CER	70-138255			
C214 B	470 pF, 50 V, CER	70-138404	C278	1 uF, 50 V, AL, ELYC	70-135147			
C214 C	270 pF, 50 V, CER	70-138403	C279	0.022 uF, 50 V, CER	70-138182			
C215 A	750 pF, 50 V, CER	70-138405	C280	1000 pF, 50 V, CER	70-138255			
C215 B	580 pF, 50 V, CER	70-138407	C281	47 pF, 50 V, CER	70-138185			
C215 C	470 pF, 50 V, CER	70-138404	C283	47 uF, 25 V, AL, ELYC	70-135144			
C216 A	270 pF, 50 V, CER	70-138403	C284	0.022 uF, 50 V, CER	70-135182			
C216 B	180 pF, 50 V, CER	70-138230	C285	220 uF, 25 V, AL, ELYC	70-131300			
C216 C	130 pF, 50 V, CER	70-138406	C401	0.1 uF, 25 V, CER	70-138327			
			C403	220 pF, 50 V, CER	70-138349			

TR-053 BOARD (CONTINUED)

REF. NO.	DESCRIPTION	PART NO.	REF. NO.	DESCRIPTION	PART NO.
CAPACITORS (CONTINUED)			CAPACITORS (CONTINUED)		
C404	10 uF, 16 V, AL, ELYC	70-138181	C533 C	150 pF, 100 V, MICA	70-138111
C406	10 uF, 16 V, AL, ELYC	70-138181	C534 A	100 pF, 100 V, MICA	70-138115
C407	0.047 uF, 50 V, CER	70-131298	C534 B	220 pF, 100 V, MICA	70-138112
C408	1 uF, 50 V, AL, ELYC	70-138184	C534 C	220 pF, 100 V, MICA	70-138112
C409	220 uF, 16 V, AL, ELYC	70-135164	C535	220 pF, 100 V, MICA	70-138112
C410	220 uF, 10 V, CER	70-135217	C536	220 pF, 100 V, MICA	70-138112
C411	0.022 uF, 50 V, CER	70-132033	C537 A	220 pF, 100 V, MICA	70-138112
C412	10 uF, 16 V, AL, ELYC	70-138181	C537 B	120 pF, 100 V, MICA	70-138116
C413	10 uF, 16 V, AL, ELYC	70-138181	C537 C	220 pF, 100 V, MICA	70-138112
C414	10 uF, 16 V, AL, ELYC	70-138181	C538 C	220 pF, 100 V, CER	70-138261
C415	10 uF, 16 V, AL, ELYC	70-138181	C538 B	100 pF, 500 V, CER	70-138264
C418	82 pF, 50 V, CER	70-138250	C538 A	1000 pF, 100 V, CER	70-138239
C417	0.01 uF, 50 V, CER	70-138270	C539 A	56 pF, 500 V, CER	70-138285
C422	220 uF, 25 V, AL, ELYC	70-135186	C539 B	120 pF, 500 V, CER	70-138306
C423	10 uF, 16 V, AL, ELYC	70-138181	C541	1000 pF, 100 V, CER	70-138239
C424	10 uF, 16 V, AL, ELYC	70-138181	C542	0.01 uF, 50 V, CER	70-131297
C425	1000 pF, 50 V, CER	70-138255	C543	47 uF, 25 V, AL, ELYC	70-135055
C426	0.01 uF, 50 V, CER	70-138270	C544	0.01 uF, 50 V, CER	70-138270
C428	0.1 uF, 25 V, CER	70-138327	C545	8 pF, 500 V, CER	70-138329
C429	0.1 uF, 25 V, CER	70-138327	C546	1000 pF, 100 V, CER	70-138239
C430	0.1 uF, 25 V, CER	70-138327	C547	1000 pF, 50 V, CER	70-138255
C431	1 uF, 50 V, AL, ELYC	70-138184	C548	1000 pF, 50 V, CER	70-138255
C432	22 uF, 16 V, AL, ELYC	70-135220	C549	0.01 uF, 50 V, CER	70-138270
C433	22 uF, 16 V, AL, ELYC	70-135220	C550	0.01 uF, 50 V, CER	70-138270
C434	2200 uF, 25 V, AL, ELYC	70-135235	C551	150 pF, 50 V, CER	70-138231
C436	220 uF, 10 V, AL, ELYC	70-135217	C560	0.1 uF, 25 V, CER	70-138327
C438	0.1 uF, 25 V, CER	70-138327	C561	10 uF, 25 V, AL, ELYC	70-135173
C439	0.1 uF, 25 V, CER	70-138327	C562 A	47 pF, 500 V, CER	70-138268
C443	0.01 uF, 50 V, CER	70-138270	C562 B	38 pF, 500 V, CER	70-138266
C446	1000 pF, 50 V, CER	70-138255	C562 C	38 pF, 500 V, CER	70-138266
C448	0.1 uF, 25 V, CER	70-138327	C563 A	47 pF, 500 V, CER	70-138268
C448	4.7 uF, 16 V, TA, ELYC	70-138101	C563 B	56 pF, 500 V, CER	70-138285
C450	1000 pF, 50 V, CER	70-138255	C564 A	120 pF, 500 V, CER	70-138306
C451	82 pF, 50 V, CER	70-138250	C564 B	100 pF, 500 V, CER	70-138264
C452	0.022 uF, 50 V, CER	70-138182	C564 C	82 pF, 500 V, CER	70-138259
C457	220 pF, 50 V, CER	70-138176	C565 A	27 pF, 500 V, CER	70-138305
C458	220 pF, 50 V, CER	70-138176	C565 B	15 pF, 500 V, CER	70-138267
C461	10 uF, 16 V, AL, ELYC	70-138181	C565 C	18 pF, 500 V, CER	70-138265
C462	10 uF, 16 V, AL, ELYC	70-138181	C566 A	150 pF, 100 V, CER	70-138258
C465	100 pF, 50 V, CER	70-138175	C566 B	120 pF, 500 V, CER	70-138306
C466	220 pF, 50 V, CER	70-138176	C566 C	100 pF, 500 V, CER	70-138264
C467	0.1 uF, 25 V, CER	70-138327	C567 A	5 pF, 500 V, CER	70-138312
C468	4.7 uF, 35 V, TA, ELYC	70-138088	C567 B	7 pF, 500 V, CER	70-138310
C502	0.01 uF, 50 V, CER	70-138270	C567 C	6 pF, 500 V, CER	70-138329
C503	1000 pF, 50 V, CER	70-138255	C568 A	91 pF, 500 V, CER	70-138307
C504	47 uF, 25 V, AL, ELYC	70-135055	C568 B	88 pF, 500 V, CER	70-138288
C506	150 pF, 50 V, CER	70-138231	C568 C	56 pF, 500 V, CER	70-138285
C507	0.01 uF, 50 V, CER	70-138270	C701	47 uF, 16 V, AL, ELYC	70-135219
C508 B	100 pF, 50 V, CER	70-138175	C702	0.022 uF, 50 V, CER	70-138162
C508 C	150 pF, 50 V, CER	70-138231	C703	1000 pF, 50 V, CER	70-138255
C509 A	470 pF, 50 V, CER	70-138404	C711	4700 pF, 50 V, CER	70-138163
C509 B	100 pF, 50 V, CER	70-138175	C712 A	68 pF, 50 V, CER	70-138229
C509 C	82 pF, 50 V, CER	70-138250	C712 B	56 pF, 50 V, CER	70-138254
C511	1000 pF, 50 V, CER	70-138255	C712 C	56 pF, 50 V, CER	70-138254
C512	0.01 uF, 25 V, CER	70-138270	C713	10 pF, 50 V, CER	70-138187
C513	15 uF, 25 V, AL, ELYC	70-135154	C714	4700 pF, 50 V, CER	70-138163
C515	1000 pF, 50 V, CER	70-138255	C715	22 pF, 50 V, CER	70-138171
C516	0.01 pF, 50 V, CER	70-138270	C716 A	150 pF, 50 V, CER	70-138231
C517	1000 pF, 50 V, CER	70-138255	C716 B	100 pF, 50 V, CER	70-138175
C519 B	22 pF, 50 V, CER	70-138171	C716 C	100 pF, 50 V, CER	70-138175
C520 A	380 pF, 50 V, CER	70-131270	C717	4700 pF, 50 V, CER	70-138163
C520 B	220 pF, 50 V, CER	70-131199	C718	4700 pF, 50 V, CER	70-138163
C520 C	270 pF, 50 V, CER	70-131226	C719 A	100 pF, 50 V, CER	70-138175
C521 A	120 pF, 50 V, CER	70-132057	C719 B	88 pF, 50 V, CER	70-138229
C521 B	150 pF, 50 V, CER	70-132055	C719 C	88 pF, 50 V, CER	70-138229
C521 C	220 pF, 50 V, CER	70-131199	C720 A	100 pF, 50 V, CER	70-138175
C522 A	120 pF, 50 V, CER	70-131057	C720 B	88 pF, 50 V, CER	70-138229
C522 B	150 pF, 50 V, CER	70-132055	C720 C	88 pF, 50 V, CER	70-138229
C522 C	220 pF, 50 V, CER	70-131199	C721	2 pF, 50 V, CER	70-138169
C523	220 pF, 50 V, CER	70-131199	C722	4700 pF, 50 V, CER	70-138163
C524	1000 pF, 50 V, CER	70-138255	C723	0.1 uF, 25 V, CER	70-138327
C525	0.01 uF, 50 V, CER	70-138270	C724	0.022 uF, 50 V, CER	70-138162
C526	2200 uF, 25 V, AL, ELYC	70-135235	C725	4700 pF, 50 V, CER	70-138163
C530 C	100 pF, 100 V, MICA	70-138115	C726	4700 pF, 50 V, CER	70-138163
C531 A	100 pF, 500 V, CER	70-138264	C727	22 pF, 50 V, CER	70-138171
C531 B	100 pF, 500 V, CER	70-138264	C730	100 pF, 50 V, CER	70-138175
C531 C	100 pF, 100 V, MICA	70-138115	C731	4700 pF, 50 V, CER	70-138163
C532 A	100 pF, 100 V, MICA	70-138115	C732	150 pF, 50 V, CER	70-138231
C532 B	120 pF, 100 V, MICA	70-138116	C733 A	5 pF, 50 V, CER	70-137065

PARTS

70-0351/0355

TR-053 BOARD (CONTINUED)

REF NO.	DESCRIPTION	PART NO.	REF NO.	DESCRIPTION	PART NO.
CAPACITORS (CONTINUED)			CAPACITORS (CONTINUED)		
C733 B	8 pF, 50 V, CER	70-138210	C803	7 pF, 50 V, CER	70-138181
C733 C	8 pF, 50 V, CER	70-138210	C804	100 pF, 50 V, CER	70-138175
C734 A	330 pF, 50 V, CER	70-138228	C805	10 pF, 50 V, CER	70-138187
C734 B	330 pF, 50 V, CER	70-138228	C806	100 pF, 50 V, CER	70-138175
C734 C	220 pF, 50 V, CER	70-138176	C807	10 pF, 50 V, CER	70-138187
C735	10 pF, 50 V, CER	70-138187	C808	100 pF, 50 V, CER	70-138175
C736 A	220 pF, 50 V, CER	70-138176	C809	0.1 uF, 25 V, CER	70-138327
C736 B	220 pF, 50 V, CER	70-138176	C810	10 pF, 50 V, CER	70-138187
C736 C	180 pF, 50 V, CER	70-138230	C811	0.1 uF, 25 V, CER	70-138327
C737	4700 pF, 50 V, CER	70-138163	C813	220 pF, 50 V, CER	70-138176
C738	4700 pF, 50 V, CER	70-138163	C814	4 pF, 50 V, CER	70-138179
C738 A	100 pF, 50 V, CER	70-138175	C815	0.047 uF, 16 V, CER	70-138409
C738 B	120 pF, 50 V, CER	70-138303	C816	0.047 uF, 16 V, CER	70-138409
C738 C	100 pF, 50 V, CER	70-138175	C818	15 pF, 50 V, CER	70-138205
C740 A	100 pF, 50 V, CER	70-138175	C819	0.022 uF, 50 V, CER	70-138162
C740 B	120 pF, 50 V, CER	70-138303	C820	0.047 uF, 16 V, CER	70-138409
C740 C	100 pF, 50 V, CER	70-138175	C821	33 pF, 50 V, CER	70-138188
C741	3 pF, 50 V, CER	70-138164	C822	0.022 uF, 50 V, CER	70-138162
C742	0.022 uF, 50 V, CER	70-138162	C823	0.047 uF, 16 V, CER	70-138409
C743	4700 pF, 50 V, CER	70-138163	C824	0.01 uF, 50 V, CER	70-138270
C744	0.022 uF, 50 V, CER	70-138162	C825	470 pF, 50 V, CER	70-138404
C745	4700 pF, 50 V, CER	70-138163	C826	0.1 uF, 50 V, CER	70-138327
C746	4700 pF, 50 V, CER	70-138163	C827	470 pF, 50 V, CER	70-138404
C747	10 pF, 50 V, CER	70-138167	C828	10 uF, 16 V, TA, ELYC	70-135165
C750	100 pF, 50 V, CER	70-138175	C829	18 pF, 50 V, CER	70-138206
C751 A	9 pF, 50 V, CER	70-138186	C830	1000 pF, 50 V, CER	70-138255
C751 B	7 pF, 50 V, CER	70-138181	C831	0.047 uF, 50 V, CER	70-138409
C751 C	6 pF, 50 V, CER	70-138210	C832	470 pF, 50 V, CER	70-138404
C752 A	27 pF, 50 V, CER	70-138165	C833	1000 pF, 50 V, CER	70-138255
C752 B	18 pF, 50 V, CER	70-138206	C834	4700 pF, 50 V, CER	70-138163
C752 C	22 pF, 50 V, CER	70-138171	C835	10 uF, 16 V, CER	70-135165
C753	2200 pF, 50 V, CER	70-138235	C836	4700 pF, 50 V, CER	70-138163
C754 A	39 pF, 50 V, CER	70-138233	C837	0.1 uF, 25 V, CER	70-138327
C754 B	33 pF, 50 V, CER	70-138168	C838	0.047 uF, 16 V, CER	70-138409
C754 C	27 pF, 50 V, CER	70-138165	C842	0.1 uF, 25 V, CER	70-138327
C755	2200 pF, 50 V, CER	70-138235	C843	0.1 uF, 25 V, CER	70-138327
C756 A	8 pF, 50 V, CER	70-138203	C821	0.022 uF, 50 V, CER	70-138162
C756 B	7 pF, 50 V, CER	70-138181	C825	1000 pF, 50 V, CER	70-138255
C756 C	6 pF, 50 V, CER	70-138210	C826	0.01 uF, 50 V, CER	70-138270
C758	3 pF, 50 V, CER	70-138184	C828	1000 pF, 50 V, CER	70-138255
C759	3 pF, 50 V, CER	70-138184	C827	1000 pF, 50 V, CER	70-138255
C760	4700 pF, 50 V, CER	70-138163	C828	1000 pF, 50 V, CER	70-138255
C761	4700 pF, 50 V, CER	70-138163	C829	22 pF, 50 V, CER	70-138171
C762 A	15 pF, 50 V, CER	70-138205	C830	47 pF, 50 V, CER	70-138185
C762 B	8 pF, 50 V, CER	70-138210	C831	10 uF, 16 V, AL, ELYC	70-138191
C762 C	3 pF, 50 V, CER	70-138164	C832	10 uF, 16 V, AL, ELYC	70-138191
C763	15 pF, 50 V, CER	70-138205	C833	1000 pF, 50 V, CER	70-138255
C765	4700 pF, 50 V, CER	70-138163	C835	0.022 uF, 50 V, CER	70-138162
C766	4700 pF, 50 V, CER	70-138163	C836	0.01 uF, 50 V, CER	70-138270
C768	8 pF, 50 V, CER	70-138203	DIODES		
C769 A	220 pF, 50 V, CER	70-138349	D101	KV1430TR01-34 (F3)	70-085312
C769 B	100 pF, 50 V, CER	70-138175	D102	KV1430TR01-34 (F3)	70-085312
C769 C	100 pF, 50 V, CER	70-138175	D201	DCC010	70-085313
C770 A	56 pF, 50 V, CER	70-138254	D202	ND487C2-3R	70-085228
C770 B	33 pF, 50 V, CER	70-138188	D241	DCA010-TA	70-085250
C770 C	22 pF, 50 V, CER	70-138171	D242	MA3088-M TW	70-085273
C771	0.022 uF, 50 V, CER	70-138162	D243	HSM88S	70-085154
C772	0.1 uF, 25 V, CER	70-138327	D244	DCA010-TA	70-085250
C773	88 pF, 50 V, CER	70-138226	D401	IMN10	70-085339
C775	0.022 uF, 50 V, CER	70-138162	D501	DWA010	70-085246
C776	47 uF, 25 V, AL, ELYC	70-135144	D602	DCA010	70-085250
C777	1000 pF, 50 V, CER	70-138255	D603	HSM88S	70-085154
C778	0.022 uF, 50 V, CER	70-138162	D604	RM4AM	70-085157
C779	0.1 uF, 50 V, PLAS	70-138189	D701	DCA010-TA	70-085250
C781	1000 pF, 50 V, CER	70-138255	D702	DCA010-TA	70-085250
C782	1 uF, 63 V, PLAS	70-137101	D711	SVC341L	70-085352
C783	0.022 uF, 50 V, CER	70-138162	D713	MA704A	70-085247
C784	0.1 uF, 50 V, PLAS	70-138189	D731	SVC341L	70-085352
C785	0.022 uF, 50 V, CER	70-138162	D733	MA704A	70-085247
C787	1000 pF, 50 V, CER	70-138255	D734	1SV186	70-085159
C788	1000 pF, 50 V, CER	70-138255	D735	1SV186	70-085159
C789 A	15 pF, 50 V, CER	70-138205	D771	DCB010-TA	70-085245
C789 B	15 pF, 50 V, CER	70-138205	D801	DCC010	70-085513
C789 C	39 pF, 50 V, CER	70-138233	D801	DCB010-TA	70-085245
C792 A	56 pF, 50 V, CER	70-138254	D802	DCA010	70-085250
C792 B	47 pF, 50 V, CER	70-138185	D803	HZM58	70-085253
C792 C	47 pF, 50 V, CER	70-138185	D804	DCA010	70-085250
C801	39 pF, 50 V, CER	70-138233	D805	DWA010-TF	70-085246
C802	100 pF, 50 V, CER	70-138175			

TR-053 BOARD (CONTINUED)

REF NO.	DESCRIPTION	PART NO.	REF NO.	DESCRIPTION	PART NO.
FILTERS			COILS (CONTINUED)		
FL241	10F12B	70-179100	L246	ELESN220KA	70-090541
FL242	10F12B	70-179100	L247	24L129	70-090542
FL243	CFU455G2	70-179093	L248	LQH3N6R8	70-090543
FL244	CFU455F2	70-179078	L249	ELESN470KA	70-090544
FL801	TPA 10.7 MA3	70-179101	L250	41L001	70-090423
INTEGRATED CIRCUITS			L251	ELESN102KA	70-090474
IC241	MC3361	70-078218	L252	ELESN47KA	70-090544
IC401	AN8541	70-078253	L253	ELESN331KA	70-090478
IC402	HA17805W	70-078567	L254	ELESN331KA	70-090478
IC404	MC144111P	70-078568	L255	ELESN47KA	70-090544
IC405	BA728F	70-078568	L256	ELESN47KA	70-090544
IC406	TDA7240AV	70-078570	L401	1.0 MH	70-178057
IC408	AN5262	70-078571	L402	ELESN4.7KA	70-090488
IC409	AN5262	70-078571	L501	C6.5T	70-090481
IC411	MPC4741G2	70-078628	L502 A	C6.5T	70-090481
IC412	AFL24F3120A14	70-078629	L502 B	C8.5T	70-090481
IC771	MB1504PF-G-BND-TF	70-078598	L502 C	C5.5T	70-090488
IC772	BU4066BF-T1	70-078573	L503 A	C5.5T	70-090488
IC801	MC1350P	70-078627	L503 B	S5.5T	70-090478
IC901	M37450M4-273SP	70-078574	L503 C	C3.5T	70-090494
IC902	MN1280R	70-078575	L504 A	S3.5T	70-090491
IC903	M6M80021L	70-078576	L504 B	S2.5T	70-090490
JACKS			L504 C	S1.5T	70-090495
J401	IL-S-14P-S2T2-EF	70-158558	L505	BL02RN1-R62	70-090122
J402	PS-10PE-D4T1-B1	70-158428	L506	C6.5T	70-090481
J403	53029-0810	70-158559	L507 A	Z1.264D 1.5T	70-090642
J404	IL-Y-4P-S15T2-EF	70-158560	L507 B	Z1.2C5D 0.5T	70-090132
J407	IL-Y-12P-S15T2-EF	70-158561	L507 C	L=7.5 W=5.0	70-090552
J408	IL-Y-13P-S15T2-EF	70-158562	L508 A	Z1.2C5D 3.5T	70-090553
J409	JM16LS-10BAT	70-158563	L508 B	Z1.2C5D 2.5T	70-090102
J410	IL-Y-10P-S15T2-EF	70-158564	L508 C	Z1.2C5D 2.5T	70-090102
J411	IL-S-15P-S2T2-EF	70-158425	L509 A	Z1.2C5D 2.5T	70-090102
J413	EMCS0552M	70-158093	L509 B	Z1.2C5D 3.5T	70-090553
J414	IL-G-2P-S3T2-E	70-158585	L510 A	S10-J 5.5T	70-090556
J420	IL-Y-4P-S15T2-EF	70-158580	L510 B	S10-H6 5.5T	70-090555
J501	M-RM	70-158090	L510 C	S10-H6 4.5T	70-090554
JUMPERS			L511 A	S10-H6 4.5T	70-090554
JP1	0 OHM, 1/10 W, MET	70-144106	L511 B	S10-H6 8.5T	70-090557
JP2	0 OHM, 1/10 W, MET	70-144108	L511 C	S10-J 5.5T	70-090556
JP3	0 OHM, 1/10 W, MET	70-144106	L512 A	S10-J 7.5T	70-090559
JP6	0 OHM, 1/10 W, MET	70-144106	L512 B	S10-H6 8.5T	70-090557
JP7	0 OHM, 1/10 W, MET	70-144108	L512 C	S10-H6 7.5T	70-090558
JP8	0 OHM, 1/10 W, MET	70-144106	L513	BL01RN-A62B1	70-090560
JP9	0 OHM, 1/10 W, MET	70-144106	L514	BL01RN-A62B1	70-090560
JP11	0 OHM, 1/10 W, MET	70-144106	L515	BL01RN-A62B1	70-090560
COILS			L516	BL02RN1-R62	70-090122
L101	42L060	70-090462	L517	BL01RN1-A62	70-090483
L132	LQH3N 1R0M02M00-100	70-090535	L518	BL01RN1-A62	70-090483
L133	LQN2AR22	70-090483	L519	ELESN4R7KA	70-090488
L134	LQN2AR22	70-090483	L520	BL01RN-A62B1	70-090560
L201	L-1S7-M1 9.5T	70-090536	L521	ELESN 1R0	70-090480
L202	L-1S7-M1 9.5T	70-090536	L525	BL01RN-A62	70-090482
L203	L-1S7-M1 9.5T	70-090536	L526	BL01RN-A62	70-090482
L204	L-1S7-M1 9.5T	70-090536	L527	BL01RN-A62	70-090482
L205	L-1S7-M1 9.5T	70-090536	L528	BL01RN-A62	70-090482
L206	L-1S7-M1 9.5T	70-090536	L530	BL01RN-A62	70-090482
L207	L-1S7-M1 9.5T	70-090536	L711	LQH3N100K02M00-100	70-090545
L208	L-1S7-M1 9.5T	70-090536	L712	LQH3N100K02M00-100	70-090545
L209	LQH3N R36M	70-090537	L713 A	L-157-M1 7.5 T	70-090547
L210	ELESN470KA	70-090544	L713 B	L-157-M1 7.5 T	70-090547
L211	DBM	70-090407	L713 C	L-157-M1 6.5 T	70-090546
L212	DBM	70-090407	L714	LQH3N100K02M00-100	70-090545
L231	LQH3N1R0M02M00	70-090535	L715	LQH3N100K02M00-100	70-090545
L232	LQN2AR22K	70-090463	L716	LQH3N1R0M02M00-100	70-090535
L233	LQN2AR22K	70-090463	L718	LQN2AR10K	70-090548
L241	LQH3NR39	70-090537	L719	LQN2AR10K	70-090548
L242	LQH3N3P3	70-090538	L720	LQN2AR10K	70-090548
L243	LQH3N3P3	70-090538	L721	LQN2AR10K	70-090548
L244	LQH3N470	70-090538	L731	LQH3N100K02M00-100	70-090545
L245	42L064	70-090540	L732	LQH3N100K02M00-100	70-090545
			L733 A	L-1S7-M1 10.5T	70-090551
			L733 B	L-1S7-M1 8.5 T	70-090550
			L733 C	L-1S7-M1 8.5T	70-090549
			L734	LQH3N100K02M00-100	70-090545
			L735	LQH3N100K02M00-100	70-090545
			L736	LQH3N100K02M00-100	70-090545
			L771	LQN2A47NM	70-090464
			L801	42L064	70-090540
			L802	42L064	70-090540
			L803	42L064	70-090540
			L804	42L064	70-090540

TR-053 BOARD (CONTINUED)

REF NO.	DESCRIPTION	PART NO.	REF NO.	DESCRIPTION	PART NO.
COILS (CONTINUED)			RESISTORS (CONTINUED)		
L805	LQH3N1R0	70-090535	R120	100 KOHM, 1/10 W, MET	70-145146
L806	LQH3N4R7	70-090513	R123	220 KOHM, 1/10 W, MET	70-145131
L807	LQH3N6R8	70-090543	R124	47 KOHM, 1/10 W, MET	70-145122
L808	ELESN102K	70-090474	R125	47 KOHM, 1/10 W, MET	70-145122
T1	17005	70-090399	R126	15 KOHM, 1/10 W, MET	70-144119
			R127	4.7 KOHM, 1/10 W, MET	70-144120
			R128	470 OHM, 1/10 W, MET	70-144152
TRANSISTORS			R129	680 OHM, 1/10 W, MET	70-144123
Q101	2SC2620B-TR (OB)	70-080181	R131	10 OHM, 1/10 W, MET	70-144115
Q102	2SC2462C-TR (LC)	70-080288	R132	470 OHM, 1/10 W, MET	70-144152
Q103	2SC2462C-TR (LC)	70-080288	R133	10 KOHM, 1/10 W, MET	70-144120
Q131	2SC3357-T2	70-080375	R135	100 OHM, 1/10 W, MET	70-145146
Q201	2SC3356	70-080192	R196	68 OHM, 1/10 W, MET	70-144114
Q203	2SC3357	70-080375	R137	100 OHM, 1/10 W, MET	70-145146
Q241	2SK125	70-080089	R201 A	47 OHM, 1/10 W, MET	70-145130
Q242	2SK360E	70-080362	R201 B	33 OHM, 1/10 W, MET	70-140320
Q243	2SC2462	70-080294	R201 C	47 OHM, 1/10 W, MET	70-145130
Q244	2SC2462	70-080294	R202	16 KOHM, 1/10 W, MET	70-144171
Q401	IMX2-T108 (X2)	70-080363	R203	580 OHM, 1/10 W, MET	70-144130
Q403	IMX2-T108 (X2)	70-080363	R204	22 KOHM, 1/10 W, MET	70-144121
Q406	2SC2462	70-080294	R205	5.6 KOHM, 1/10 W, MET	70-144168
Q408	2SK508	70-080191	R206	22 OHM, 1/10 W, MET	70-144160
Q409	2SC2462	70-080294	R207 B	470 OHM, 1/10 W, MET	70-144152
Q410	2SC2462	70-080294	R207 C	270 OHM, 1/10 W, MET	70-144116
Q501	2SC2538	70-080108	R208 B	10 OHM, 1/10 W, MET	70-144115
Q502	2SC1671	70-080054	R208 C	0 OHM, 1/10 W, MET	70-144106
Q503	2SC2630	70-080091	R208 D	470 OHM, 1/10 W, MET	70-144152
Q504	2SB1085Q	70-080367	R209 C	270 OHM, 1/10 W, MET	70-144116
Q701	2SC2462C	70-080288	R231	470 OHM, 1/10 W, MET	70-144152
Q702	IMB3-T110 (B3)	70-080364	R232	10 KOHM, 1/10 W, MET	70-144120
Q703	IMH1-T1	70-080296	R234	22 OHM, 1/10 W, MET	70-144160
Q704	2SB798	70-080184	R235	270 OHM, 1/10 W, MET	70-144116
Q705	DTC124EK	70-080274	R236	18 OHM, 1/10 W, MET	70-144171
Q711	3SK151GR	70-080303	R237	270 OHM, 1/10 W, MET	70-144116
Q712	2SC2351-T2B R3	70-080218	R241	47 OHM, 1/10 W, MET	70-145130
Q731	3SK151GR-TE85L	70-080303	R242	150 OHM, 1/10 W, MET	70-140321
Q732	2SC2351-T2V R3	70-080218	R243	470 OHM, 1/10 W, MET	70-144152
Q733	2SC2351-T2V R3	70-080218	R244	5.6 KOHM, 1/10 W, MET	70-144168
Q734	2SC2351-T2V R3	70-080218	R245	3.3 KOHM, 1/10 W, MET	70-144118
Q771	IMD3-T1	70-080297	R248	100 OHM, 1/10 W, MET	70-145146
Q772	IMH1-T1	70-080296	R247	82 KOHM, 1/10 W, MET	70-144173
Q773	2SC2462C	70-080288	R248	22 KOHM, 1/10 W, MET	70-144121
Q774	2SA1122C	70-080182	R249	150 OHM, 1/10 W, MET	70-140321
Q775	2SA1121C	70-080339	R250	12 KOHM, 1/10 W, MET	70-144111
Q778	2SC2462LC	70-080294	R251	330 OHM, 1/10 W, MET	70-144184
Q778	IMH1	70-080296	R252	3.9 KOHM, 1/10 W, MET	70-145132
Q801	2SK508K52	70-080324	R254	0 OHM, 1/10 W, MET	70-144106
Q802	2SK508K52	70-080324	R255	1.2 KOHM, 1/10 W, MET	70-144167
Q803	3SK151GR	70-080303	R256	82 KOHM, 1/10 W, MET	70-144173
Q804	2SC2462C	70-080288	R257	47 KOHM, 1/10 W, MET	70-144122
Q805	2SA1121C	70-080339	R258	470 KOHM, 1/10 W, MET	70-144188
Q806	2SA1121C	70-080339	R259	2.2 KOHM, 1/10 W, MET	70-144113
Q807	2SC2462	70-080180	R260	5.6 KOHM, 1/10 W, MET	70-144168
Q808	2SA1121C	70-080339	R261	3.3 KOHM, 1/10 W, MET	70-144118
Q809	2SSA1121C	70-080339	R262	82 KOHM, 1/10 W, MET	70-144173
Q810	2SA1121C	70-080339	R263	10 KOHM, 1/10 W, MET	70-144120
Q811	2SC2462C	70-080180	R264	27 KOHM, 1/10 W, MET	70-144183
Q812	DTC124EK	70-080300	R265	15 KOHM, 1/10 W, MET	70-144122
RESISTORS			R266	47 KOHM, 1/10 W, MET	70-144231
R101	47 KOHM, 1/10 W, MET	70-145145	R401	270 OHM, 1/4 W, MET	70-144193
R102	47 KOHM, 1/10 W, MET	70-145145	R402	22 KOHM, 1/10 W, MET	70-144121
R103	47 KOHM, 1/10 W, MET	70-145145	R404	33 KOHM, 1/10 W, MET	70-144112
R104	47 KOHM, 1/10 W, MET	70-145145	R405	1 KOHM, 1/10 W, MET	70-144125
R108	22 KOHM, 1/10 W, MET	70-144121	R406	100 KOHM, 1/10 W, MET	70-144321
R107	1 KOHM, 1/4 W, MET	70-144288	R407	100 KOHM, 1/10 W, MET	70-144321
R108	10 KOHM, 1/10 W, MET	70-144120	R408	100 KOHM, 1/10 W, MET	70-144321
R109	4.7 KOHM, 1/10 W, MET	70-144123	R409	100 KOHM, 1/10 W, MET	70-144321
R110	2.2 KOHM, 1/10 W, MET	70-144113	R410	33 KOHM, 1/10 W, MET	70-144112
R111	1.5 KOHM, 1/10 W, MET	70-144134	R411	22 KOHM, 1/10 W, MET	70-144121
R112	10 KOHM, 1/10 W, MET	70-144120	R412	10 KOHM, 1/10 W, MET	70-144120
R113	4.7 KOHM, 1/10 W, MET	70-144123	R413	1 KOHM, 1/10 W, MET	70-144125
R114	1 KOHM, 1/10 W, MET	70-144125	R414	15 KOHM, 1/10 W, MET	70-144122
R115	100 OHM, 1/10 W, MET	70-145146	R415	150 KOHM, 1/10 W, MET	70-144129
R116	100 OHM, 1/10 W, MET	70-145146	R416	68 KOHM, 1/10 W, MET	70-144119
R117	220 OHM, 1/10 W, MET	70-144184	R417	4.7 KOHM, 1/10 W, MET	70-144123
R118	10 KOHM, 1/10 W, MET	70-144120	R418	100 KOHM, 1/10 W, MET	70-145146
R119	100 KOHM, 1/10 W, MET	70-145148	R419	330 KOHM, 1/10 W, MET	70-140318
			R421	150 KOHM, 1/10 W, MET	70-144129
			R422	22 KOHM, 1/10 W, MET	70-144121
			R423	100 KOHM, 1/10 W, MET	70-144321

TR-053 BOARD (CONTINUED)

REF NO.	DESCRIPTION	PART NO.	REF NO.	DESCRIPTION	PART NO.
RESISTORS (CONTINUED)			RESISTORS (CONTINUED)		
R424	47 KOHM, 1/10 W, MET	70-145145	R716	6.8 KOHM, 1/10 W, MET	70-144156
R425	12 KOHM, 1/10 W, MET	70-144111	R717	150 OHM, 1/10 W, MET	70-140321
R426	1 KOHM, 1/10 W, MET	70-144125	R718	3.3 KOHM, 1/10 W, MET	70-144118
R427	4.7 KOHM, 1/10 W, MET	70-144123	R719	1 KOHM, 1/10 W, MET	70-144125
R428	680 OHM, 1/10 W, MET	70-144157	R720	100 OHM, 1/10 W, MET	70-145145
R430	1 KOHM, 1/10 W, MET	70-144125	R721	47 OHM, 1/10 W, MET	70-145130
R431	1.5 KOHM, 1/10 W, MET	70-144134	R722	47 OHM, 1/10 W, MET	70-145130
R434	15 KOHM, 1/10 W, MET	70-144122	R731	47 OHM, 1/10 W, MET	70-145130
R435	10 KOHM, 1/10 W, MET	70-144120	R732	6.8 KOHM, 1/10 W, MET	70-144158
R436	22 KOHM, 1/10 W, MET	70-144121	R733	10 KOHM, 1/10 W, MET	70-144120
R437	10 KOHM, 1/10 W, MET	70-144120	R734	22 KOHM, 1/10 W, MET	70-144121
R439	1 KOHM, 1/10 W, MET	70-144125	R735	22 KOHM, 1/10 W, MET	70-144121
R440	150 KOHM, 1/10 W, MET	70-144287	R736	1 KOHM, 1/10 W, MET	70-144125
R441	100 KOHM, 1/10 W, MET	70-144322	R737	150 OHM, 1/10 W, MET	70-140321
R442	1 KOHM, 1/10 W, MET	70-144288	R738	3.3 KOHM, 1/10 W, MET	70-144118
R443	39 KOHM, 1/10 W, MET	70-144290	R739	1 KOHM, 1/10 W, MET	70-144125
R444	82 KOHM, 1/10 W, MET	70-144291	R740	100 OHM, 1/10 W, MET	70-145146
R445	100 KOHM, 1/10 W, MET	70-144119	R741	47 OHM, 1/10 W, MET	70-145130
R446	22 KOHM, 1/10 W, MET	70-144188	R742	47 OHM, 1/10 W, MET	70-145130
R447	4.7 KOHM, 1/10 W, MET	70-144123	R751	47 KOHM, 1/10 W, MET	70-145145
R448	10 KOHM, 1/10 W, MET	70-144120	R752	47 KOHM, 1/10 W, MET	70-145145
R452	330 OHM, 1/8 W, MET	70-144065	R754	3.3 KOHM, 1/10 W, MET	70-144118
R453	100 OHM, 1/10 W, MET	70-144115	R755	1 KOHM, 1/10 W, MET	70-144125
R455	10 KOHM, 1/10 W, MET	70-144120	R756	100 OHM, 1/10 W, MET	70-145146
R456	10 KOHM, 1/10 W, MET	70-144120	R757	47 OHM, 1/10 W, MET	70-145130
R457	2.2 KOHM, 1/10 W, MET	70-144113	R758	1 KOHM, 1/10 W, MET	70-144125
R458	330 OHM, 1/10 W, MET	70-144164	R759	3.3 KOHM, 1/10 W, MET	70-144118
R461	1 KOHM, 1/10 W, MET	70-144125	R780	100 OHM, 1/10 W, MET	70-145146
R462	3.3 KOHM, 1/10 W, MET	70-144118	R781	0 OHM, 1/10 W, MET	70-144106
R463	560 OHM, 1/10 W, MET	70-144130	R782	0 OHM, 1/10 W, MET	70-144106
R464	2.7 KOHM, 1/10 W, MET	70-144159	R770	47 KOHM, 1/10 W, MET	70-145145
R465	100 KOHM, 1/10 W, MET	70-144321	R771	100 KOHM, 1/10 W, MET	70-144321
R466	47 KOHM, 1/10 W, MET	70-145145	R772	22 OHM, 1/10 W, MET	70-144180
R467	47 KOHM, 1/10 W, MET	70-145145	R773	100 KOHM, 1/10 W, MET	70-144321
R470	22 KOHM, 1/10 W, MET	70-144121	R774	1 KOHM, 1/10 W, MET	70-144125
R471	0 OHM, 1/10 W, MET	70-144106	R775	0 OHM, 1/10 W, MET	70-144106
R472	22 KOHM, 1/10 W, MET	70-144121	R776	47 KOHM, 1/10 W, MET	70-145145
R501	2.2 KOHM, 1/10 W, MET	70-144113	R777	4.7 KOHM, 1/10 W, MET	70-144123
R502	220 OHM, 1/10 W, MET	70-144194	R778	10 KOHM, 1/10 W, MET	70-144120
R503	10 OHM, 1/10 W, MET	70-144115	R779	22 KOHM, 1/10 W, MET	70-144121
R504	10 OHM, 1/10 W, MET	70-144115	R780	0 OHM, 1/10 W, MET	70-144106
R505	10 OHM, 1/10 W, MET	70-144115	R782	4.7 KOHM, 1/10 W, MET	70-144123
R507 A	33 OHM, 1/10 W, MET	70-144005	R783	47 KOHM, 1/10 W, MET	70-145145
R507 B	68 OHM, 1/10 W, MET	70-144008	R784	47 KOHM, 1/10 W, MET	70-145145
R507 C	68 OHM, 1/10 W, MET	70-144008	R785	100 KOHM, 1/10 W, MET	70-144321
R508 A	68 OHM, 1/10 W, MET	70-144008	R786	22 KOHM, 1/10 W, MET	70-144121
R508 B	33 OHM, 1/10 W, MET	70-144005	R787	100 OHM, 1/10 W, MET	70-145146
R508 C	68 OHM, 1/10 W, MET	70-144006	R788	22 OHM, 1/10 W, MET	70-144180
R509 A	33 OHM, 1 W, MET	70-144201	R789	4.7 KOHM, 1/10 W, MET	70-144123
R509 B	180 OHM, 1 W, MET	70-144313	R790	1 KOHM, 1/10 W, MET	70-144125
R509 C	180 OHM, 1 W, MET	70-144313	R781	1 KOHM, 1/10 W, MET	70-144125
R511	150 OHM, 1/10 W, MET	70-140321	R782	4.7 KOHM, 1/10 W, MET	70-144123
R512	150 OHM, 1/10 W, MET	70-140321	R783	47 KOHM, 1/10 W, MET	70-145145
R513	250 OHM, 1/10 W, MET	70-140321	R784	1.5 KOHM, 1/10 W, MET	70-144134
R514	33 OHM, 2 W, MET	70-144135	R795	47 KOHM, 1/10 W, MET	70-145145
R515	100 OHM, 1/10 W, MET	70-145146	R796	22 KOHM, 1/10 W, MET	70-144121
R516	100 OHM, 1/10 W, MET	70-145146	R797	5.6 KOHM, 1/10 W, MET	70-144188
R517	100 OHM, 1/10 W, MET	70-145146	R798	1 KOHM, 1/10 W, MET	70-144125
R518	100 OHM, 1/10 W, MET	70-145146	R799	2.7 KOHM, 1/10 W, MET	70-144159
R519	4.7 KOHM, 1/10 W, MET	70-144123	R801	4.7 KOHM, 1/10 W, MET	70-144123
R521	100 KOHM, 1/10 W, MET	70-144321	R802	3.3 KOHM, 1/10 W, MET	70-144118
R522	100 KOHM, 1/10 W, MET	70-144321	R803	10 KOHM, 1/10 W, MET	70-144120
R524	1 KOHM, 1/10 W, MET	70-144125	R804	10 KOHM, 1/10 W, MET	70-144120
R525	180 OHM, 1/8 W, MET	70-144012	R805	3.3 KOHM, 1/10 W, MET	70-144118
R526	180 OHM, 1/8 W, MET	70-144012	R806	4.7 KOHM, 1/10 W, MET	70-144123
R527	180 OHM, 1/8 W, MET	70-144012	R807	560 OHM, 1/10 W, MET	70-144130
R528	180 OHM, 1/8 W, MET	70-144012	R808	4.7 KOHM, 1/10 W, MET	70-144123
R529	180 OHM, 1/8 W, MET	70-144012	R809	3.3 KOHM, 1/10 W, MET	70-144118
R701	220 OHM, 1/10 W, MET	70-144194	R810	3.3 KOHM, 1/10 W, MET	70-144118
R702	47 KOHM, 1/10 W, MET	70-145145	R811	10 KOHM, 1/10 W, MET	70-144120
R704	47 KOHM, 1/10 W, MET	70-145145	R812	220 OHM, 1/10 W, MET	70-144194
R705	47 KOHM, 1/10 W, MET	70-145145	R813	2.2 KOHM, 1/10 W, MET	70-144113
R706	47 KOHM, 1/10 W, MET	70-145145	R814	150 OHM, 1/10 W, MET	70-140321
R707	220 OHM, 1/10 W, MET	70-144194	R815	470 OHM, 1/10 W, MET	70-144152
R708	4.7 KOHM, 1/10 W, MET	70-144123	R816	8.2 KOHM, 1/10 W, MET	70-14305
R711	47 OHM, 1/10 W, MET	70-145130	R817	1 KOHM, 1/10 W, MET	70-144286
R712	6.8 KOHM, 1/10 W, MET	70-144158	R818	470 OHM, 1/10 W, MET	70-144152
R713	10 KOHM, 1/10 W, MET	70-144120	R819	150 OHM, 1/10 W, MET	70-140321
R714	22 KOHM, 1/10 W, MET	70-144121	R820	150 OHM, 1/10 W, MET	70-140321
R715	22 KOHM, 1/10 W, MET	70-144121	R821	5.6 KOHM, 1/10 W, MET	70-144188

PARTS

70-0351/0355

REF NO.	DESCRIPTION	PART NO.	REF NO.	DESCRIPTION	PART NO.
RESISTORS (CONTINUED)			RESISTORS (CONTINUED)		
R822	1.8 KOHM, 1/10 W, MET	70-144154	R963	1 KOHM, 1/10 W, MET	70-144125
R823	2.2 KOHM, 1/10 W, MET	70-144113	R964	22 KOHM, 1/10 W, MET	70-144121
R824	8.2 KOHM, 1/10 W, MET	70-140305	R965	1 KOHM, 1/10 W, MET	70-144125
R825	220 OHM, 1/10 W, MET	70-144194	R966	10 KOHM, 1/10 W, MET	70-144120
R826	10 KOHM, 1/10 W, MET	70-144120	R967	22 KOHM, 1/10 W, MET	70-144121
R827	10 KOHM, 1/10 W, MET	70-144120	R968	10 KOHM, 1/10 W, MET	70-144120
R828	560 OHM, 1/10 W, MET	70-144130	R971	47 KOHM, 1/10 W, MET	70-145145
R829	680 OHM, 1/10 W, MET	70-144157	R972	820 OHM, 1/10 W, MET	70-144185
R830	88 OHM, 1/10 W, MET	70-144114	R973	820 OHM, 1/10 W, MET	70-144185
R831	1 KOHM, 1/10 W, MET	70-144125	R974	820 OHM, 1/10 W, MET	70-144185
R832	10 KOHM, 1/10 W, MET	70-144120	R978	100 KOHM, 1/10 W, MET	70-144321
R833	180 OHM, 1/10 W, MET	70-144150	R979	22 KOHM, 1/10 W, MET	70-144121
R835	1 KOHM, 1/10 W, MET	70-144125	R980	10 KOHM, 1/10 W, MET	70-144120
R836	100 KOHM, 1/10 W, MET	70-144321	R981	1 KOHM, 1/10 W, MET	70-144125
R837	47 KOHM, 1/10 W, MET	70-144145	R982	1 KOHM, 1/10 W, MET	70-144125
R838	10 KOHM, 1/10 W, MET	70-144120	R983	22 KOHM, 1/10 W, MET	70-144121
R839	5.6 KOHM, 1/10 W, MET	70-144188	R984	1 KOHM, 1/10 W, MET	70-144125
R840	33 OHM, 1/10 W, MET	70-140320	R985	3.9 KOHM, 1/10 W, MET	70-145132
R842	33 OHM, 1/10 W, MET	70-140320	R986	4.7 KOHM, 1/10 W, MET	70-144123
R843	33 OHM, 1/10 W, MET	70-140320	R988	1 MOHM, 1/10 W, MET	70-144155
R811	22 KOHM, 1/10 W, MET	70-144121	R989	1 KOHM, 1/10 W, MET	70-144125
R812	22 KOHM, 1/10 W, MET	70-144121	R991	22 KOHM, 1/10 W, MET	70-144121
R813	22 KOHM, 1/10 W, MET	70-144121	R992	10 KOHM, 1/10 W, MET	70-144120
R814	22 KOHM, 1/10 W, MET	70-144121	R996	10 KOHM, 1/10 W, MET	70-144120
R815	22 KOHM, 1/10 W, MET	70-144121	R997	100 KOHM, 1/10 W, MET	70-144321
R816	22 KOHM, 1/10 W, MET	70-144121	R998	220 KOHM, 1/10 W, MET	70-144131
R821	1 KOHM, 1/10 W, MET	70-144125			
R822	1 KOHM, 1/10 W, MET	70-144125			
R823	1 KOHM, 1/10 W, MET	70-144125			
R824	1 KOHM, 1/10 W, MET	70-144125			
R825	1 KOHM, 1/10 W, MET	70-144125			
R826	1 KOHM, 1/10 W, MET	70-144125			
R827	470 OHM, 1/10 W, MET	70-144152			
R831	47 KOHM, 1/10 W, MET	70-145145			
R832	47 KOHM, 1/10 W, MET	70-145145			
R833	47 KOHM, 1/10 W, MET	70-145145			
R835	22 KOHM, 1/10 W, MET	70-144121			
R836	0 OHM, 1/10 W, MET	70-144108			
R837	1 KOHM, 1/10 W, MET	70-144125			
R845	1 KOHM, 1/10 W, MET	70-144125			
R846	1 KOHM, 1/10 W, MET	70-144125			
R847	1 KOHM, 1/10 W, MET	70-144125			
R848	1 KOHM, 1/10 W, MET	70-144125			
R849	1 KOHM, 1/10 W, MET	70-144125			
R851	1 KOHM, 1/10 W, MET	70-144125			
R852	1 KOHM, 1/10 W, MET	70-144125			
R853	1 KOHM, 1/10 W, MET	70-144125			
R854	1 KOHM, 1/10 W, MET	70-144125			
R855	1 KOHM, 1/10 W, MET	70-144125			
R856	1 KOHM, 1/10 W, MET	70-144125			
R857	1 KOHM, 1/10 W, MET	70-144125			
R858	0 OHM, 1/10 W, MET	70-144108			
R859	10 KOHM, 1/10 W, MET	70-144120			
R861	1 KOHM, 1/10 W, MET	70-144125			
				VARIABLE RESISTORS	
			RV241	RH082KCJ3 (2.2K)	70-184109
			RV401	100K	70-184110
				MISCELLANEOUS	
				INSULATION PLATE	70-157357
				SHIELD CASE	70-089339
			CA511	CABLE, L = 150	70-034059
			CA513	CABLE, L = 250	70-034844
			CB001	CNTL12XS102M	70-088071
			CB002	CNTL9XS102M	70-088072
			CM201	IL-S-2P-S2T2-EF	70-159399
			CM701	IL-S-2P-S2T2-EF	70-159399
			F501	FUSE, 5A	70-204082
			K501	RELAY, HB1-DC6V	70-105010
			P403	PLUG, 53029-BCPB	70-159587
			P410	PLUG, IL-Y-105	70-159854
			RC901	RC9019/CR8602	70-088073
			RC902	RC9020/CR8402	70-088074
			SW801	SWITCH	70-183119
			X101	CRYSTAL, HC-431u 12.8 MHz	70-128087
			X241	43U 10.245 MHz	70-128025
			X901	XTAL, AT-51, 8.000 MHz	70-128099

CONTROL HEAD

70-0351/0355 A BAND USE "A"		70-0351/0355 B BAND USE "B"		70-0351/0355 C BAND USE "C"		UD = Under-dash only TM = Trunk-mount only		
REF. NO.	DESCRIPTION	PART NO.	REF. NO.	DESCRIPTION	PART NO.	REF. NO.	DESCRIPTION	PART NO.
CAPACITORS			RESISTORS					
C301	0.01 uF, 50 V, CER	70-138270	R313	33 KOHM, 1/10 W, MET	70-144112			
C302	1000 pF, 50 V, CER	70-138170	R314	150 OHM, 1/8 W, MET	70-144011			
C303	0.01 uF, 50 V, CER	70-138270	R316	150 OHM, 1/8 W, MET	70-144011			
C304	1 uF, 50 V, AL ELYC	70-138194	R317	330 OHM, 1/8 W, MET	70-144184			
C305	1000 pF, 50 V, CER	70-138170	VARIABLE RESISTORS					
C306	1000 pF, 50 V, CER	70-138170						
C307 (UD)	470 uF, 25 V, AL ELYC	70-135237	RV301	K1214005L (10KB)	70-180025			
C331 TM	1000 pF, 45 V, CER	70-131387	RV302	K1214105G (10KB)	70-180028			
CABLE ASSEMBLIES			SWITCHES					
CA301	SMV 2d 15x21	70-034620						
CA302	SMV 2d 3x8	70-034821	S301	ESB-64803	70-183080			
CA303-1	ILYB-15P-ILS 15S	70-034622	S302	ESB-64803	70-183080			
CA303-2	ILYB-14P-ILS 14S	70-034623	S303	ESB-64803	70-183080			
CA304	ILG 2S-S3C2	70-034624	S304	ESB-64803	70-183080			
CA324 TM	1282R L=120	70-034630	S305	SRBU1C L=15MM	70-183084			
DIODES			JACKS					
D301	LED LB 402	70-202066	J301	NS1504L	70-159100			
D302	SLM-245 LMW TE84L	70-085316	J304	IL-G-2P-S3T2-EF	70-159565			
D303	SLM-125MT TE84L	70-085317	J321 TM	D3431	70-159593			
D304	SLM-125MT TE84L	70-085317	J322 TM	IL-S-15P-S2T2-EF	70-159425			
D305	SLM-125MT TE84L	70-085317	J323 TM	IL-S-14P-S2T2-EF	70-159558			
D306	SLM-125MT TE84L	70-085317	J324 TM	IL-S-14P-S2T2-EF	70-159558			
INTEGRATED CIRCUITS			JUMPERS					
IC301	AN6997K	70-078577						
IC302	BU74HC174F-T1	70-078578	JP301	0 OHM, 1/10 W, MET	70-144106			
TRANSISTORS			JP302	0 OHM, 1/10 W, MET	70-144106			
Q301	2SA1121C-TR	70-080338	JP303	0 OHM, 1/10 W, MET	70-144106			
Q302	IMH1-T1	70-080296	JP304	0 OHM, 1/10 W, MET	70-144106			
Q303	IMH1-T1	70-080296	JP306	0 OHM, 1/10 W, MET	70-144106			
RESISTORS			JP307	0 OHM, 1/10 W, MET	70-144106			
R301	880 OHM, 1/10 W, MET	70-144157	JP308	0 OHM, 1/10 W, MET	70-144106			
R303	270 OHM, 1/10 W, MET	70-144116	JP309	0 OHM, 1/10 W, MET	70-144106			
R304	270 OHM, 1/10 W, MET	70-144116	JP310	0 OHM, 1/10 W, MET	70-144106			
R305	270 OHM, 1/10 W, MET	70-144116	JP331 TM	0 OHM, 1/10 W, MET	70-144106			
R306	270 OHM, 1/10 W, MET	70-144116	JP332 TM	0 OHM, 1/10 W, MET	70-144106			
R308	330 KOHM, 1/10 W, MET	70-140318	JP333 TM	0 OHM, 1/10 W, MET	70-144106			
R309	47 KOHM, 1/10 W, MET	70-145145	JP334 TM	0 OHM, 1/10 W, MET	70-144106			
R310	47 KOHM, 1/10 W, MET	70-145145	MISCELLANEOUS					
R311	47 KOHM, 1/10 W, MET	70-145145	CD301	PHOTO SENSOR P1201	70-085054			
R312	220 KOHM, 1/10 W, MET	70-144131	SP301 UD	SPEAKER	70-080033			



PARTS

70-0351/0355

Z-593 TRUNK-MOUNT INTERFACE BOARD

70-0355 A BAND USE "A"			70-0355 B BAND USE "B"			70-0355 C BAND USE "C"		
REF NO.	DESCRIPTION	PART NO.	REF NO.	DESCRIPTION	PART NO.			
CAPACITORS			CONNECTORS					
C311	0.01 uF, 50 V, CER	70-138270	J311	D3431	70-158582			
C312	0.01 uF, 50 V, CER	70-138270	JUMPERS					
C313	0.01 uF, 50 V, CER	70-138270	JP311	0 OHM, 1/10 W, MET	70-144108			
C314	0.01 uF, 50 V, CER	70-138270	JP312	0 OHM, 1/10 W, MET	70-144108			
C318	0.01 uF, 50 V, CER	70-138270	JP313	0 OHM, 1/10 W, MET	70-144108			
C317	0.01 uF, 50 V, CER	70-138270	JP318	0 OHM, 1/10 W, MET	70-144108			
C318	0.01 uF, 50 V, CER	70-138270	JP317	0 OHM, 1/10 W, MET	70-144108			
C319	0.01 uF, 50 V, CER	70-138270	JP318	0 OHM, 1/10 W, MET	70-144108			
C321	0.01 uF, 50 V, CER	70-138270	JP319	0 OHM, 1/10 W, MET	70-144108			
C322	0.01 uF, 50 V, CER	70-138270	JP321	0 OHM, 1/10 W, MET	70-144108			
C328	4.7 uF, 50 V, CER	70-138068	JP322	0 OHM, 1/10 W, MET	70-144108			
CABLE ASSEMBLIES			JP323	0 OHM, 1/10 W, MET	70-144108			
CA311	IL-YB-14P-IL-S-14S	70-034827	JP324	0 OHM, 1/10 W, MET	70-144108			
CA312	IL-3-2P-IL-G-2S	70-034828	SWITCHES					
CA313	ILJ2P-EMCHUM0201W	70-034825	K311	RELAY AGP9003	70-105022			
CA316	IL-YE-15P-IL-S-15S	70-034598						
DIODES								
D311	DCB010	70-085323						

70-2157 CTCSS FILTER BOARD

70-0351/0355 A BAND USE "A"			70-0351/0355 B BAND USE "B"			70-0351/0355 C BAND USE "C"		
REF NO.	DESCRIPTION	PART NO.	REF NO.	DESCRIPTION	PART NO.			
CAPACITORS			RESISTORS					
C1	6.3 uF, 10 V, AL, ELYC	70-135335	R1	10 KOHM, 1/10 W, MET	70-144120			
C2	680 pF, 50 V, CER	70-138252	R2	12 KOHM, 1/10 W, MET	70-144111			
C4	6.3 uF, 10 V, AL, ELYC	70-135335	R3	10 KOHM, 1/10 W, MET	70-144120			
C5	0.1 uF, 25 V, CER	70-138327	R4	100 KOHM, 1/10 W, MET	70-145128			
C8	6.3 uF, 10 V, AL, ELYC	70-135335	R5	100 KOHM, 1/10 W, MET	70-145128			
C7	1 uF, 50 V, CER	70-135257	R6	150 KOHM, 1/10 W, MET	70-144129			
C8	0.022 uF, 25 V, CER	70-138162	R7	120 KOHM, 1/10 W, MET	70-144310			
C8	1500 pF, 50 V, CER	70-138204	R9	1 KOHM, 1/10 W, MET	70-144125			
C10	1500 pF, 50 V, CER	70-138204	R10	27 KOHM, 1/10 W, MET	70-144183			
C50	0.01 uF, 50 V, CER	70-138270	R11	470 KOHM, 1/10 W, MET	70-144189			
C51	0.01 uF, 25 V, PLAS	70-137128	R12	2.2 KOHM, 1/10 W, MET	70-144113			
C52	0.01 uF, 25 V, PLAS	70-137128	R13	22 KOHM, 1/10 W, MET	70-144121			
C53	0.01 uF, 25 V, PLAS	70-137128	R14	3.3 KOHM, 1/10 W, MET	70-144118			
C54	0.01 uF, 25 V, PLAS	70-137128	R15	1 KOHM, 1/10 W, MET	70-144125			
C55	0.01 uF, 25 V, PLAS	70-137128	R16	1 KOHM, 1/10 W, MET	70-144125			
C56	0.01 uF, 25 V, PLAS	70-137128	R17	36 KOHM, 1/10 W, MET	70-144196			
C57	0.01 uF, 25 V, PLAS	70-137128	R18	22 KOHM, 1/10 W, MET	70-144121			
C58	0.01 uF, 25 V, PLAS	70-137128	R20	100 KOHM, 1/10 W, MET	70-145128			
C59	1 uF, 50 V, AL, ELYC	70-135257	R50	820 OHM, 1/10 W, MET	70-144185			
C80	0.01 uF, 50 V, CER	70-138270	R51	24 KOHM, 1/10 W, MET	70-144306			
C81	0.01 uF, 50 V, CER	70-138270	R52	0 OHM, 1/10 W, MET	70-144108			
C82	6.8 uF, 10 V, AL, ELYC	70-135335	R53	27 KOHM, 1/10 W, MET	70-144183			
INTEGRATED CIRCUITS			R54	4.3 KOHM, 1/10 W, MET	70-144307			
IC1	MF6CN-50	70-078611	R55	560 KOHM, 1/10 W, MET	70-144308			
IC2	BU4066BF	70-078573	R56	18 KOHM, 1/10 W, MET	70-144185			
IC50	BA10324F	70-078612	R57	56 KOHM, 1/10 W, MET	70-144189			
TRANSISTORS			R58	12 KOHM, 1/10 W, MET	70-144111			
Q1	2SC2462C	70-080288	R59	150 KOHM, 1/10 W, MET	70-144129			
Q2	2SC2462C	70-080288	R60	270 OHM, 1/10 W, MET	70-144118			
VARIABLE RESISTORS			R61	180 KOHM, 1/10 W, MET	70-144309			
RV1	50 KOHM	70-184114	R62	100 KOHM, 1/10 W, MET	70-145128			
			MISCELLANEOUS					
			P403	SCREW BIND HD M26 x 8 CONNECTOR 5513-8CP8	70-150188 70-156567			

REPLACEMENT PARTS ORDERING

To speed delivery and avoid errors, always include the following information when ordering replacement parts:

1. Best identification of the parts.
 - A. MIDLAND part number, or
 - B. Model and Serial numbers of equipment in which the part is used, with
 - C. Part description, and
 - D. Schematic reference designator, and,
 - E. If necessary, return the old part as sample.
2. Specify quantity desired of each part.
3. Ship-to address (and billing address if different).

Mail or phone your order to:

MIDLAND INTERNATIONAL CORPORATION
1690 North Topping Avenue
Kansas City, Missouri 64120
(816) 241-8500



1690 NORTH TOPPING • KANSAS CITY • MISSOURI • 64120
(P.O. BOX 419903 • KANSAS CITY • MISSOURI • 64141)
TELEPHONE: (816) 241-8500 • FAX: (816) 245-1144

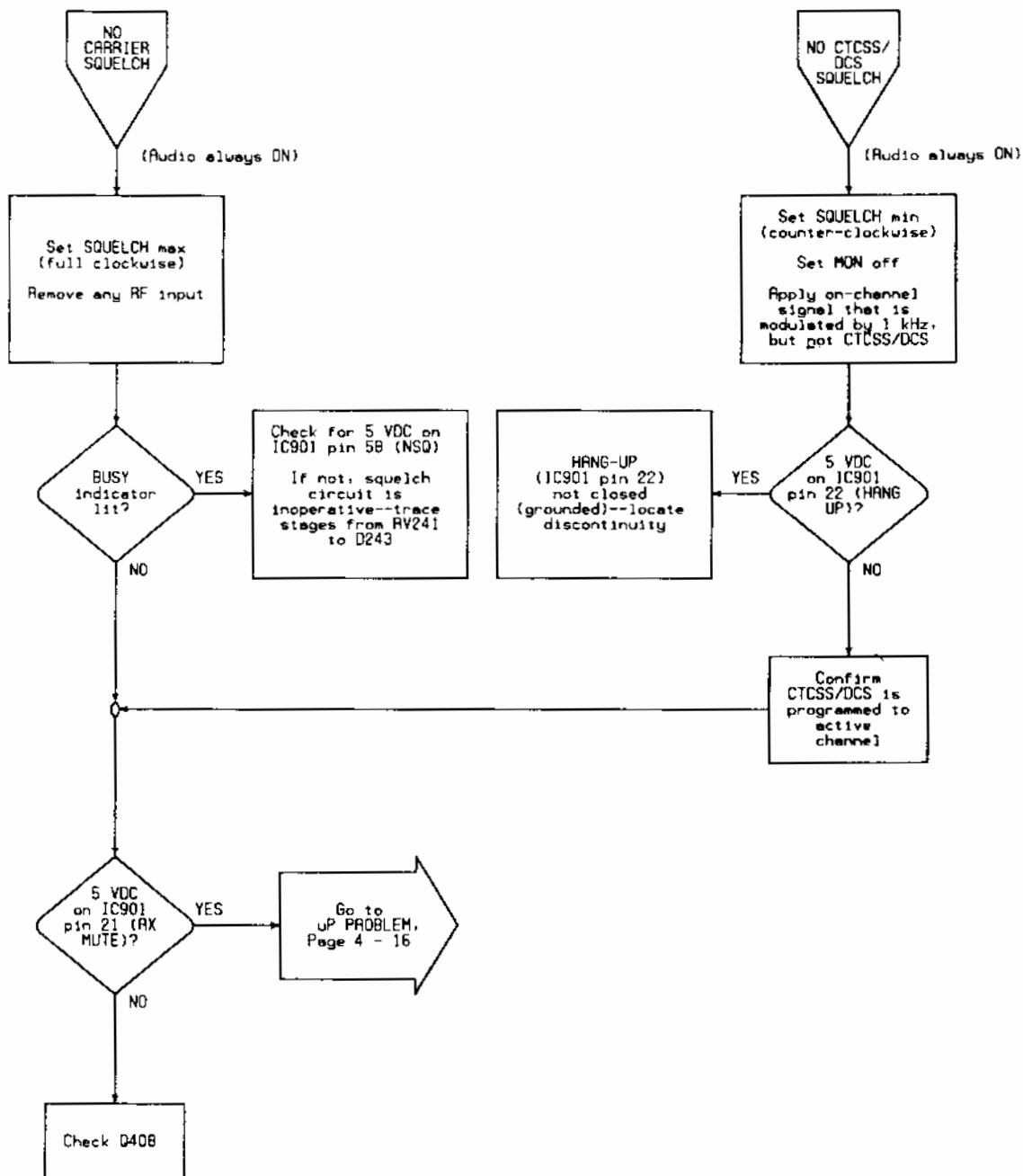

Troubleshooting Chart 4 - 5 — Squelch Problem

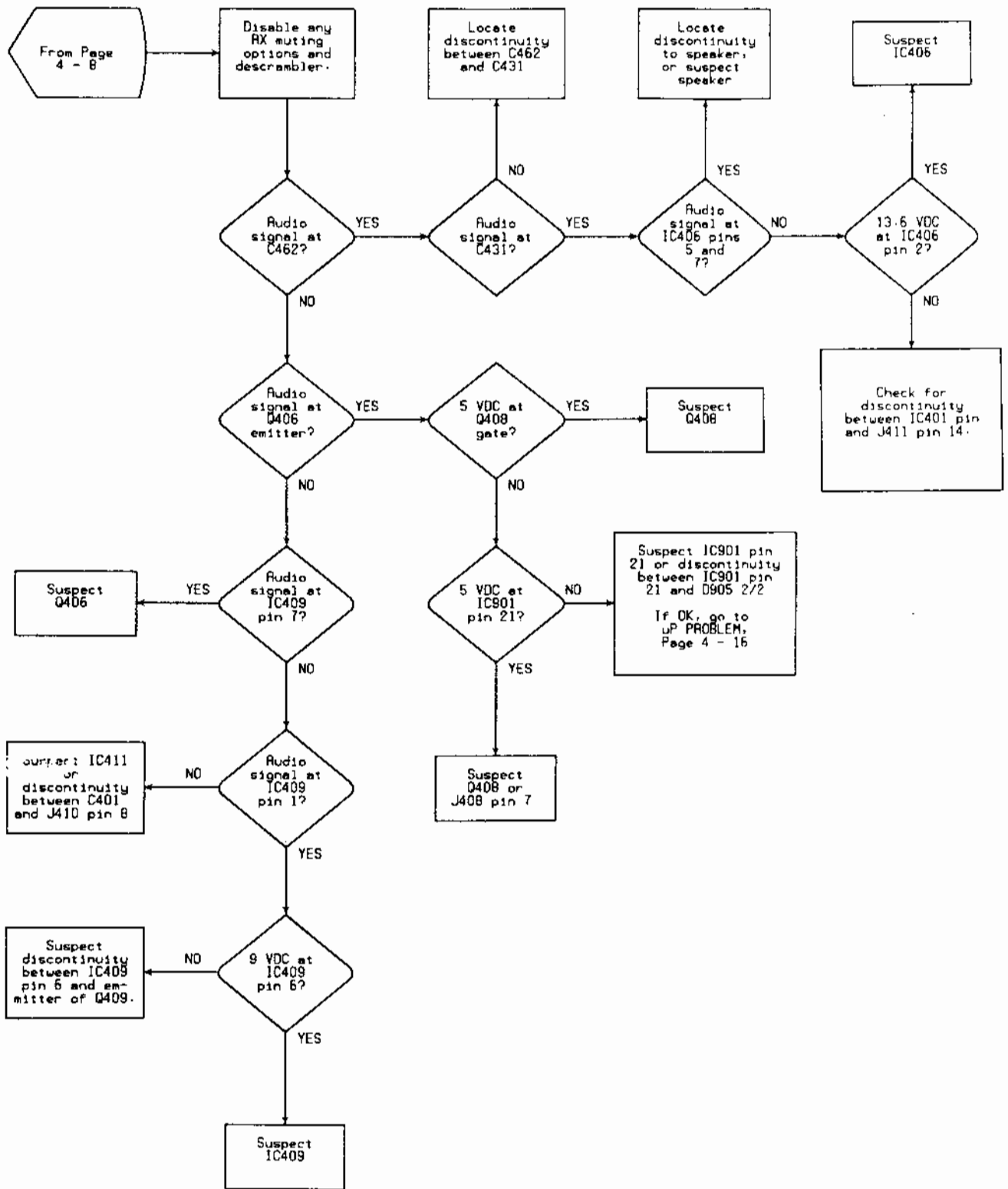

Troubleshooting Chart 4 - 4b — Receiver Problem (Continued)

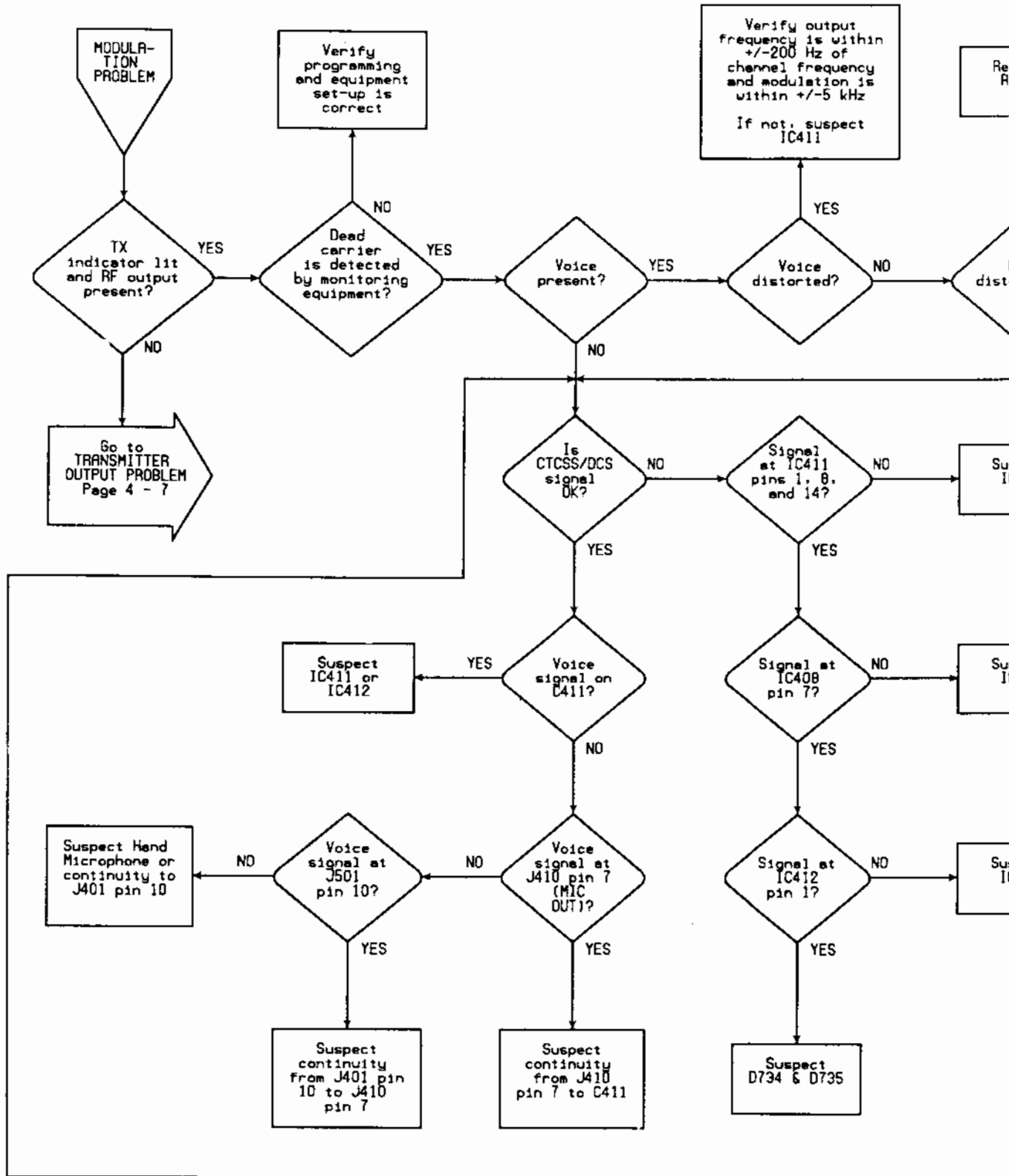

Troubleshooting Chart 4 - 6 — Modulation Problem

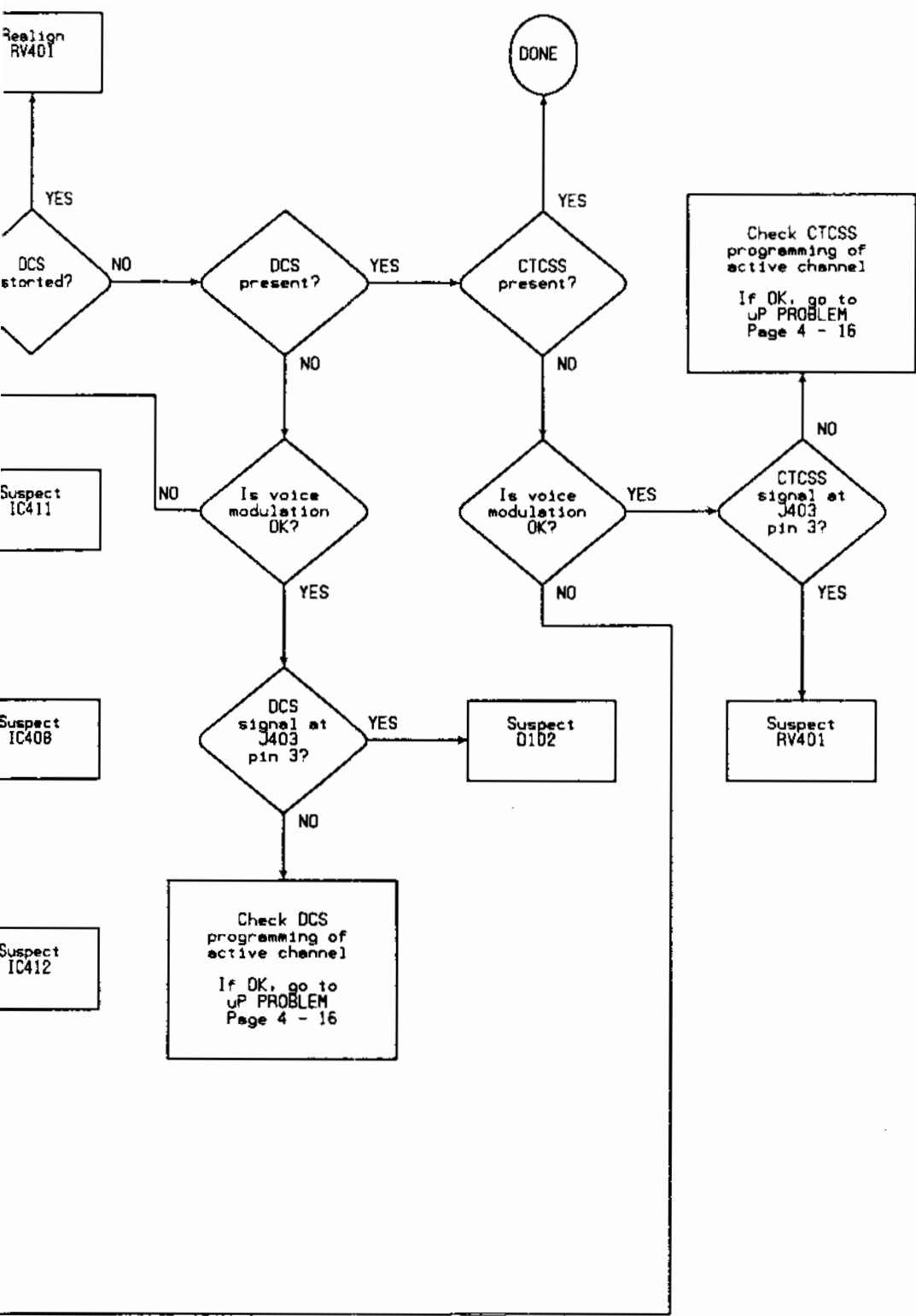

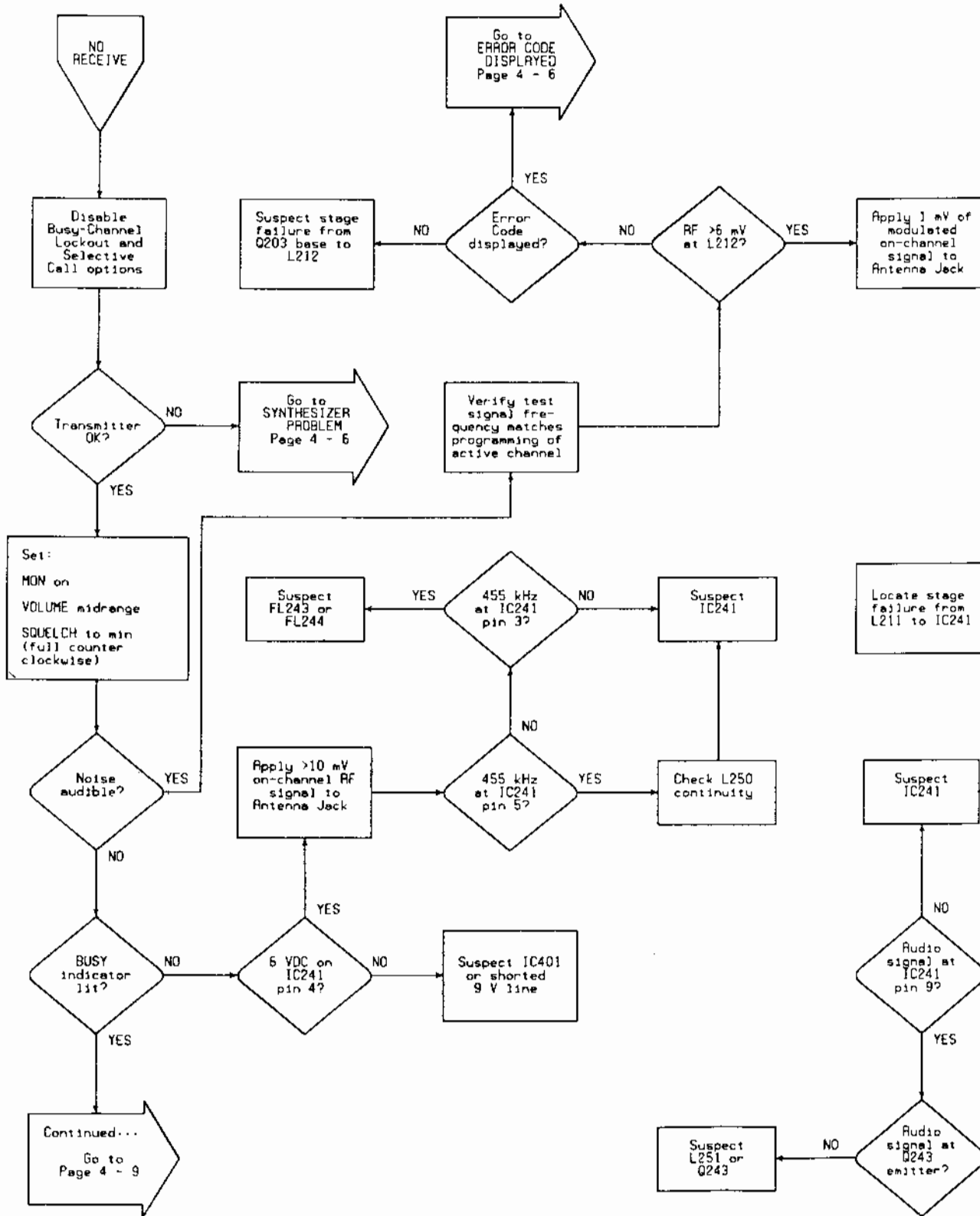

Troubleshooting Chart 4 - 4a — Receiver Problem

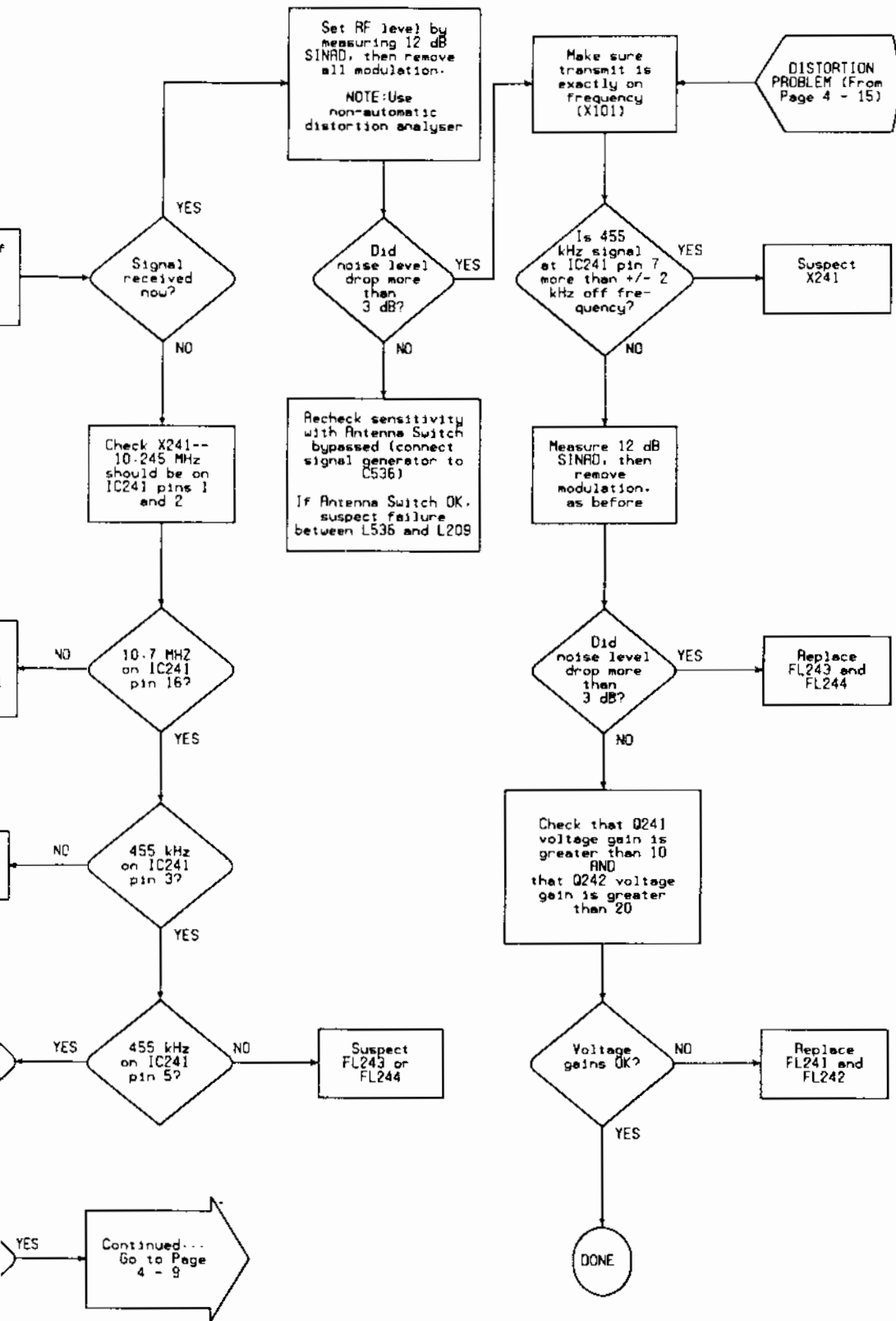

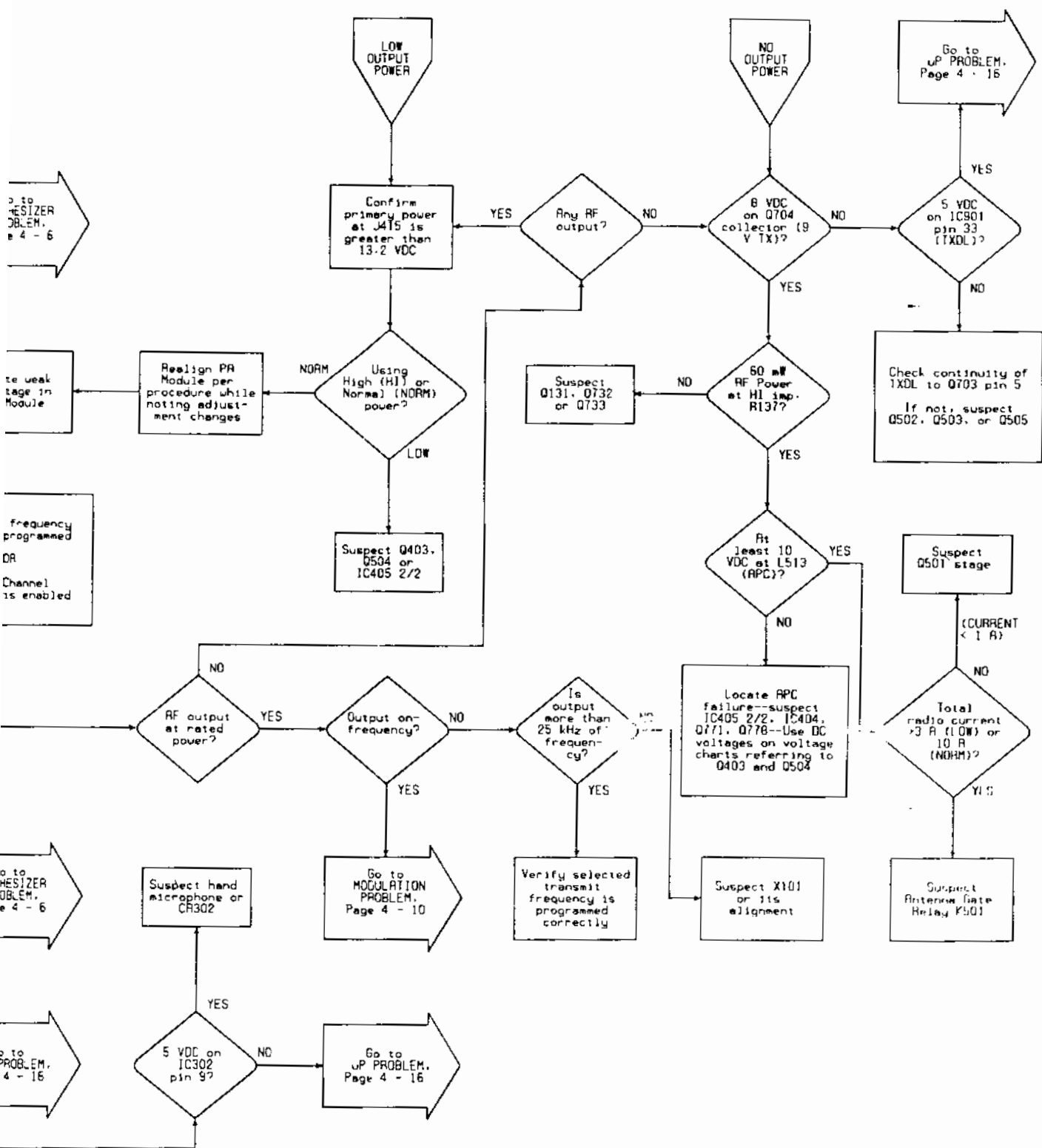

Troubleshooting Chart 4 - 3 — Transmitter Problem

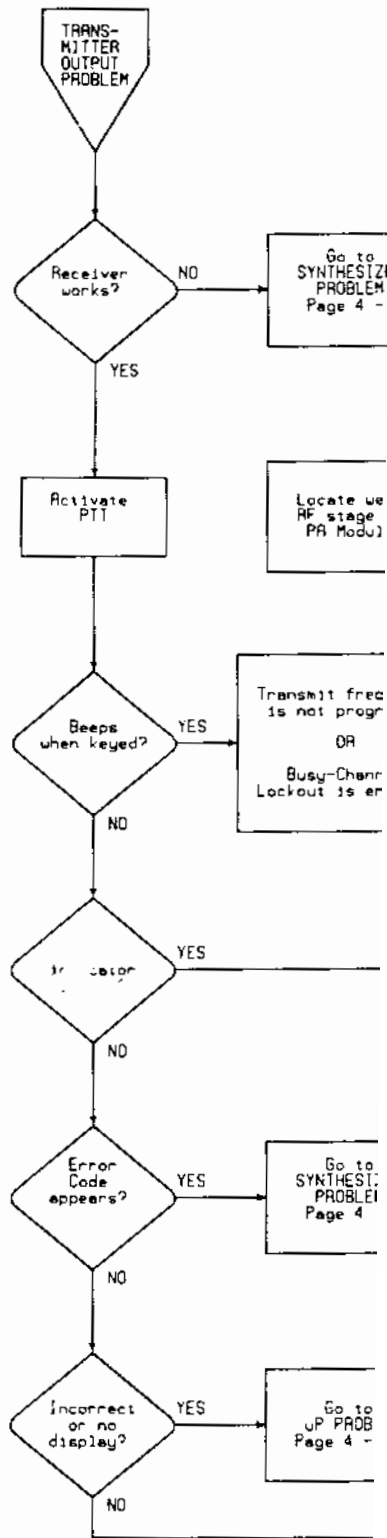

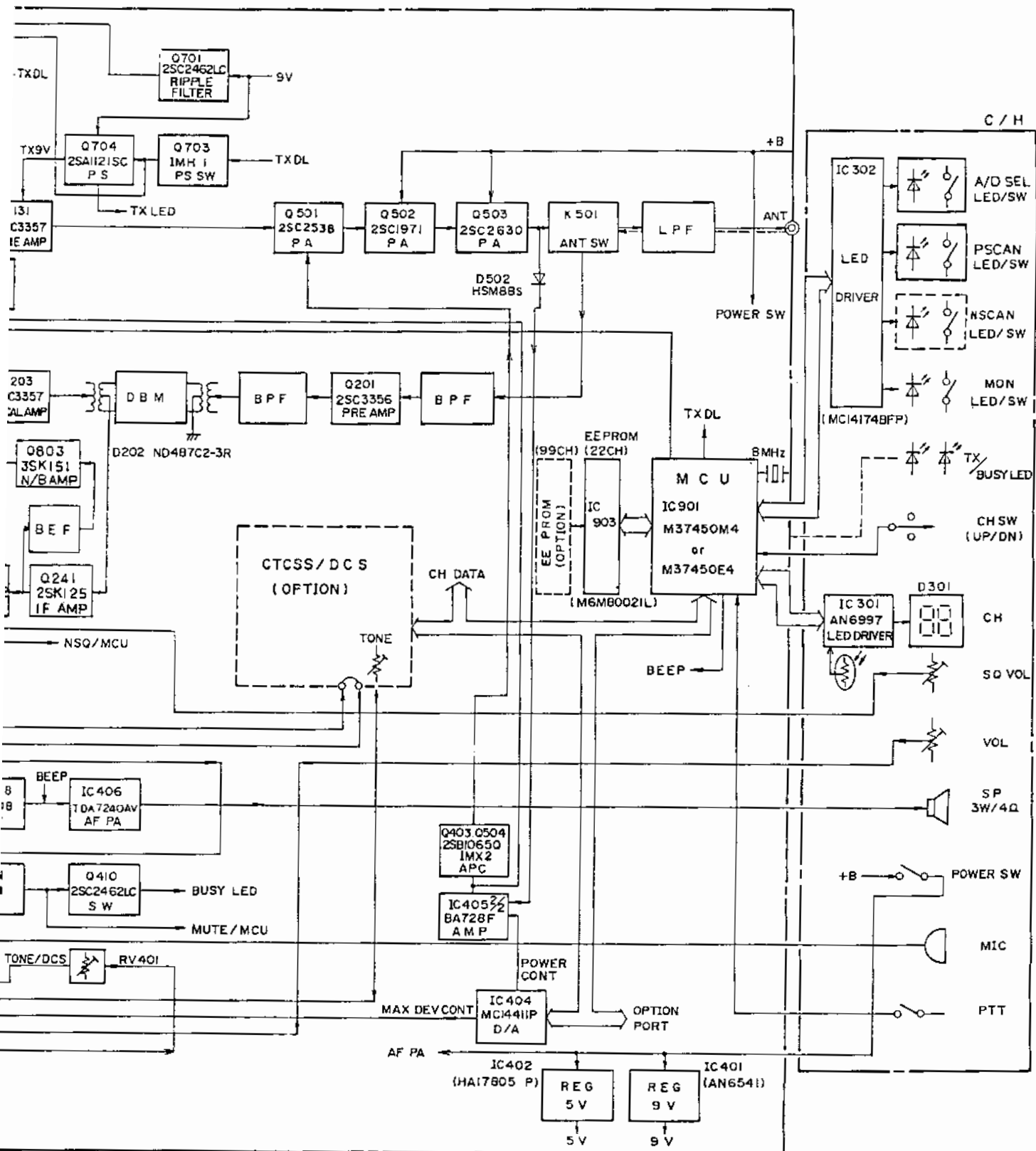

OPTION

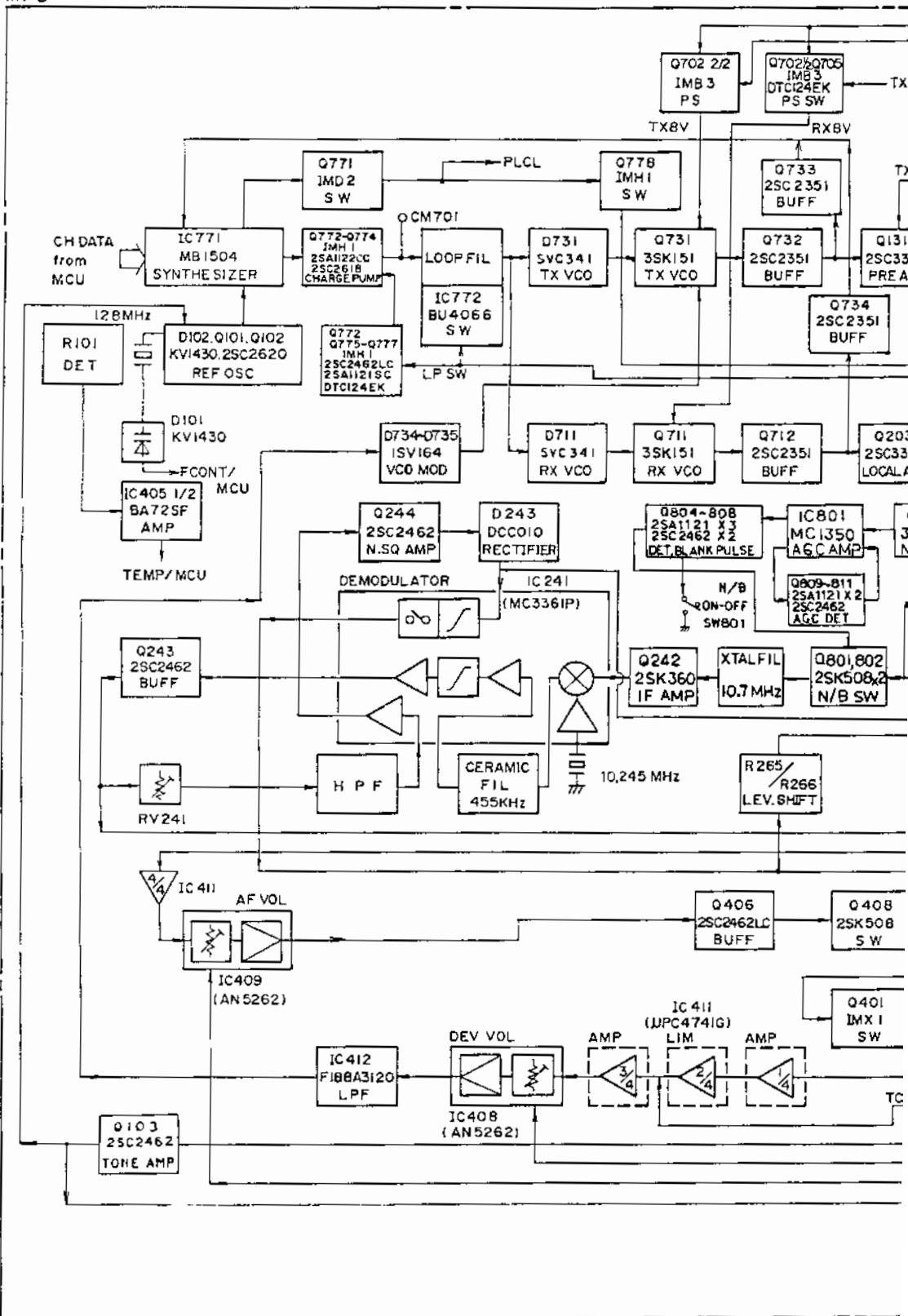

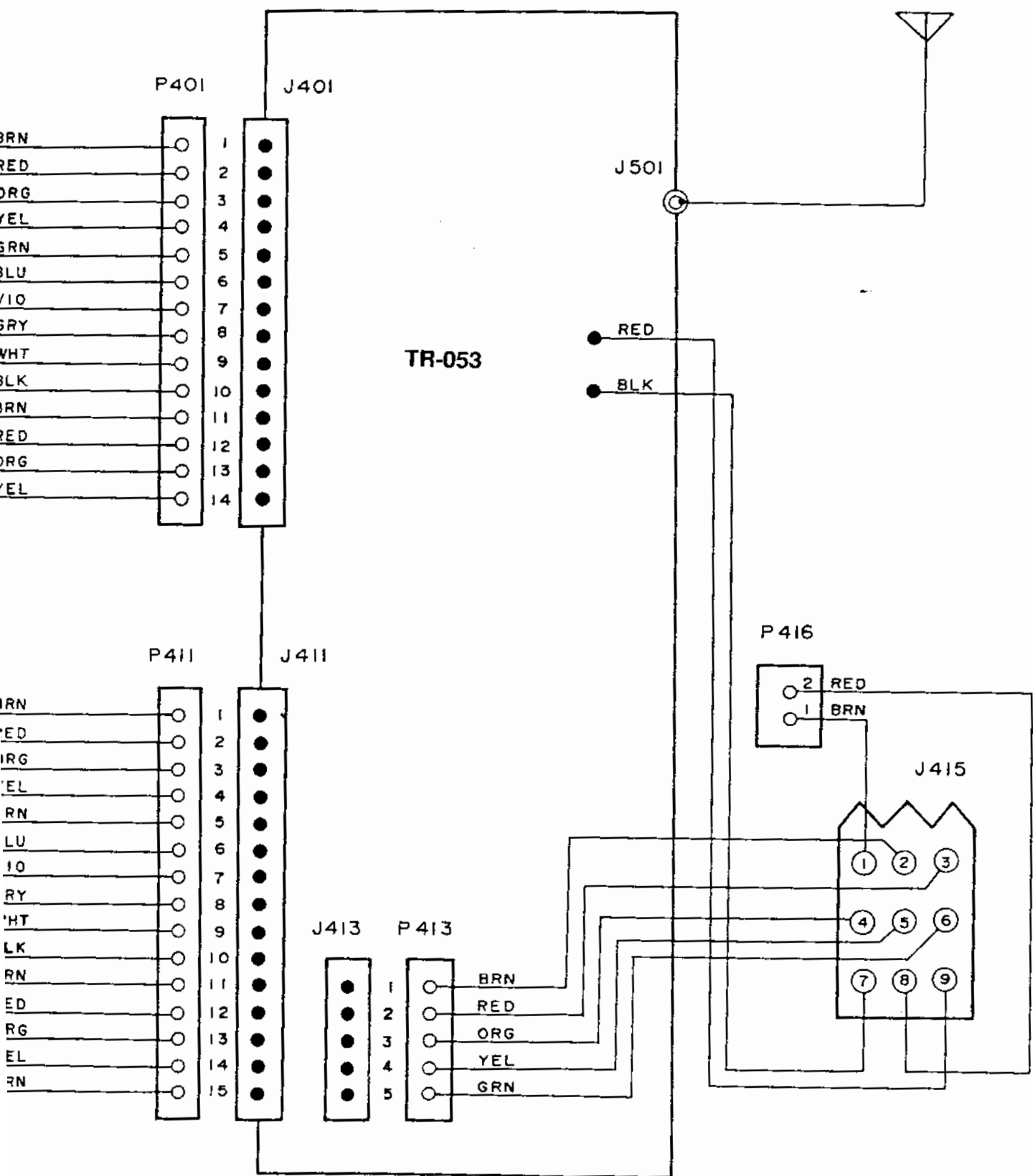

UNDER-DASH WIRING DIAGRAM

70-0351/0355

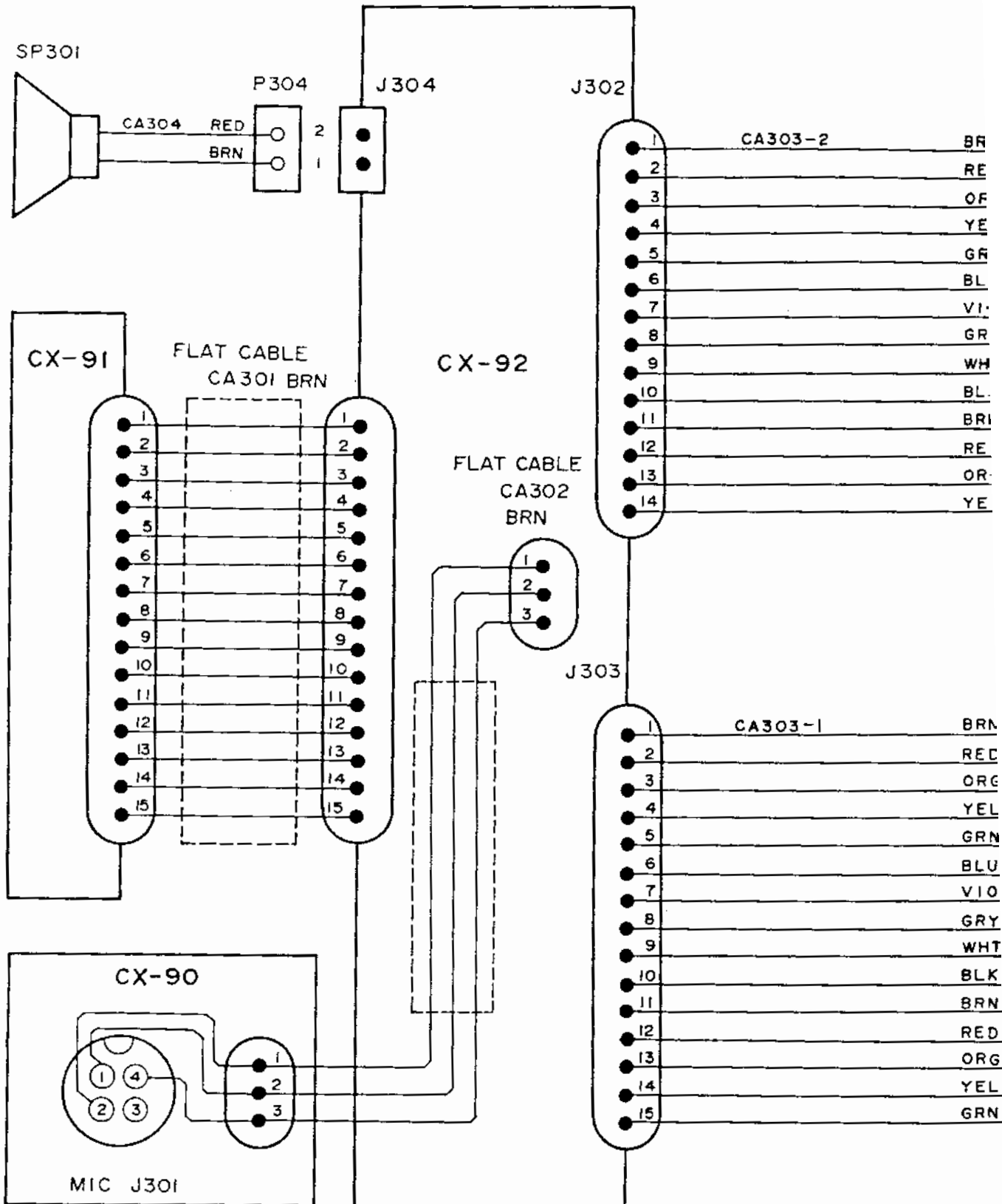

TRUNK-MOUNT WIRING DIAGRAM

70-0351/0355

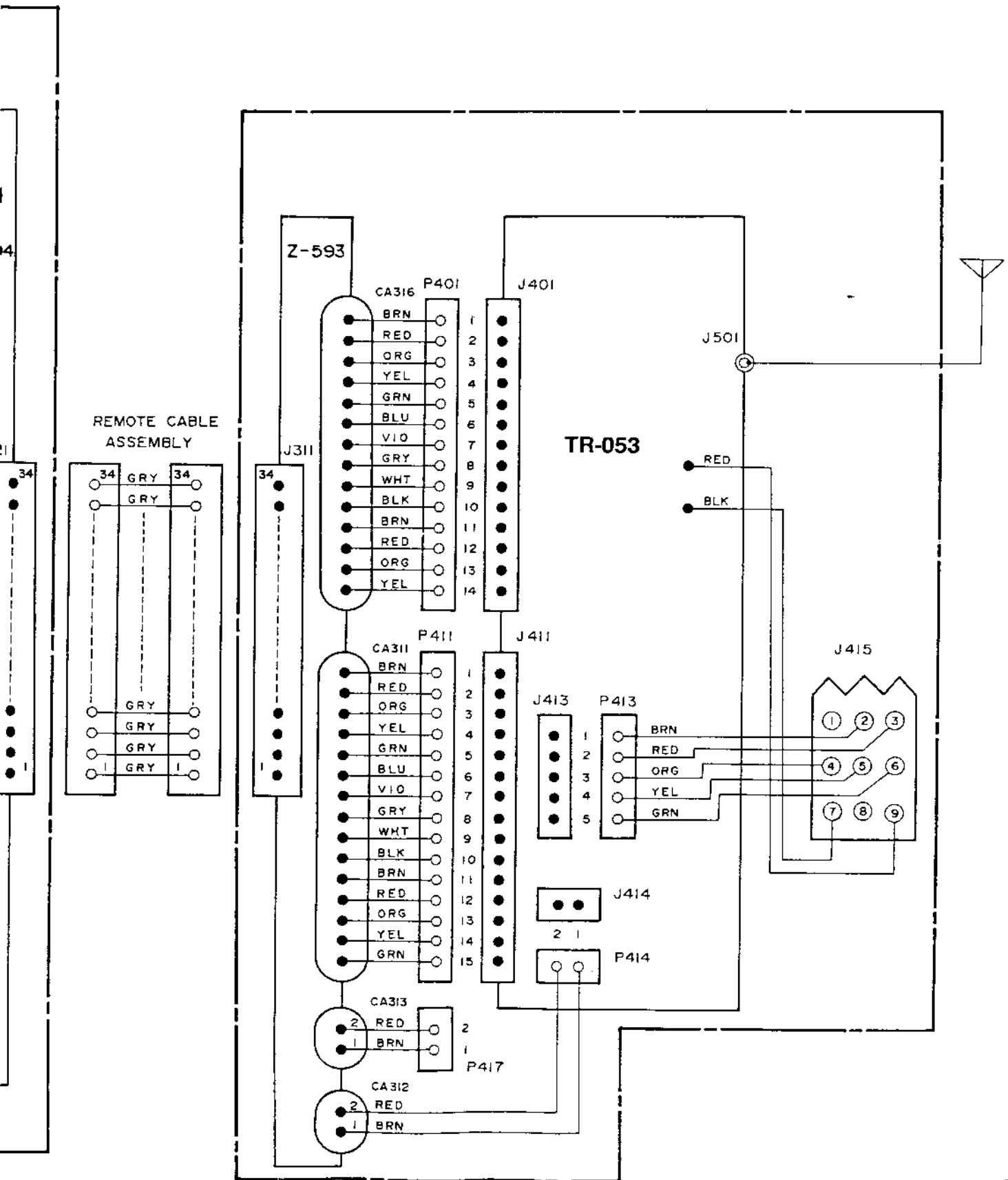

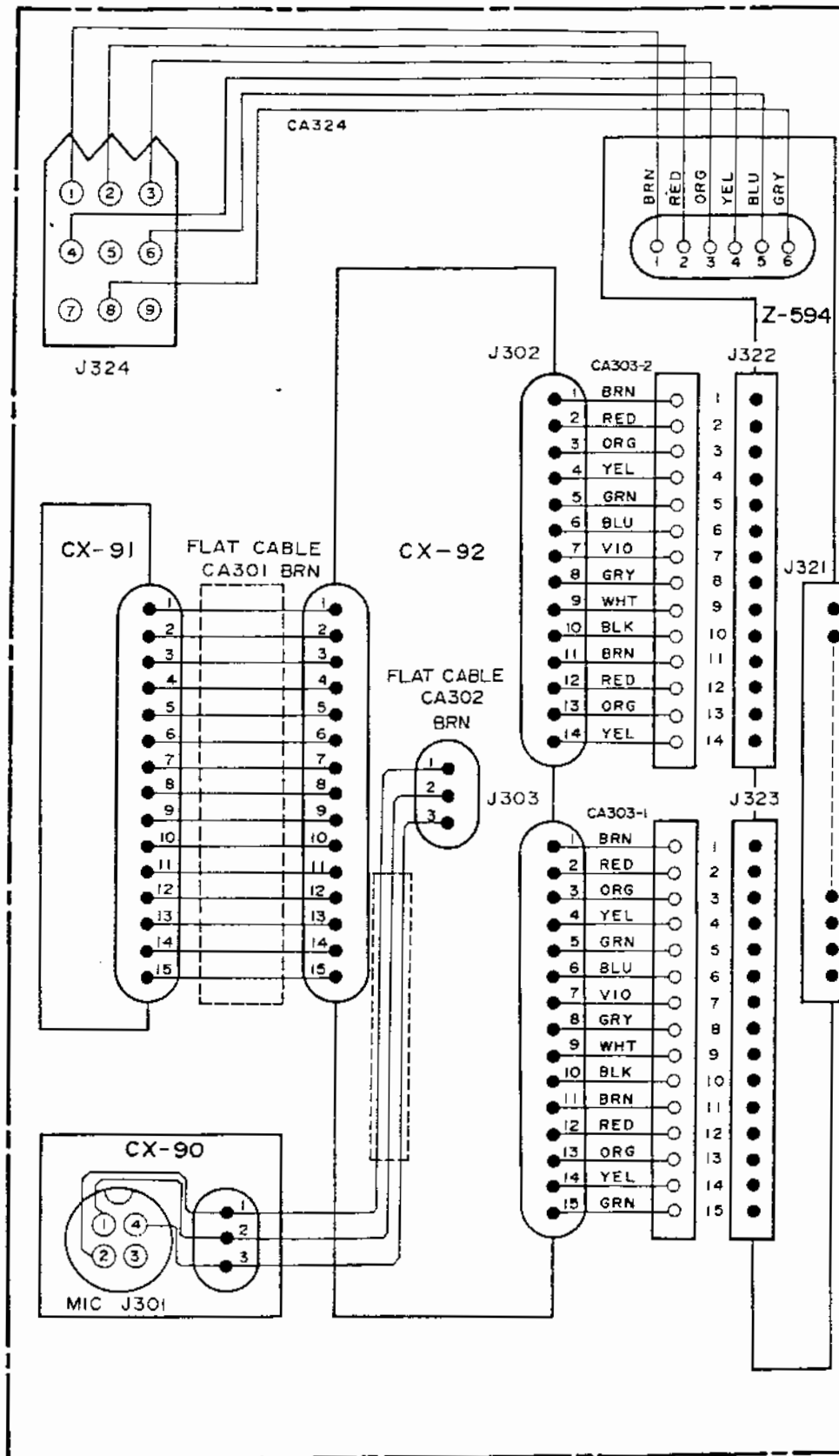

CONTROL HEAD LAYOUTS

70-0351/0355

CX-90 LAYOUT BOTTOM VIEW



CX-90 LAYOUT TOP VIEW



P11
MIC
D40



6 - 6

CX-91 LAYOUT BOTTOM VIEW

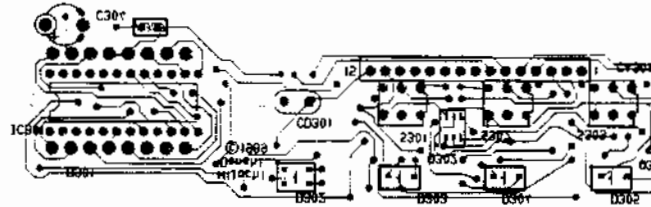
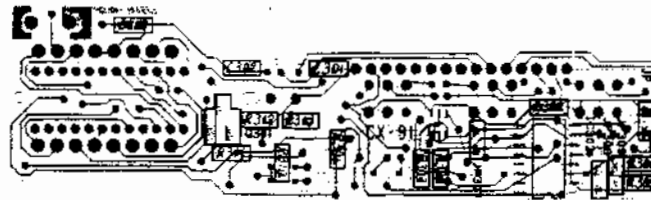

CX-91 LAYOUT TOP VIEW

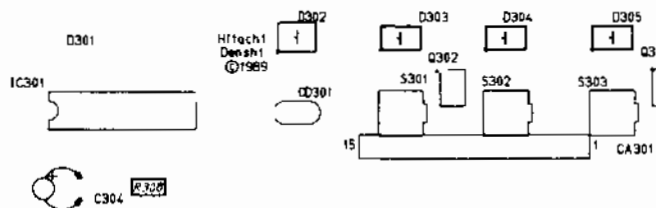
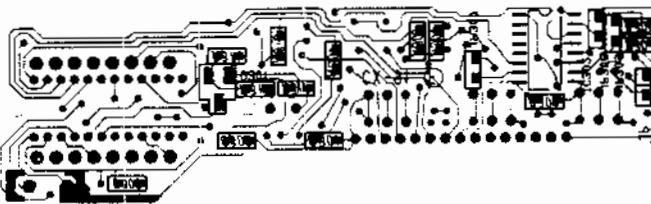
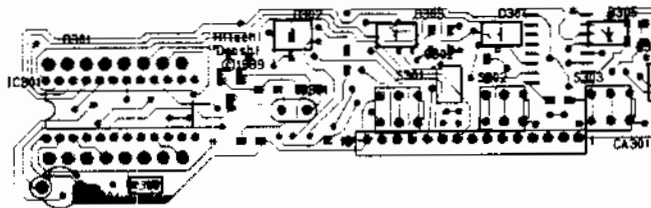



CX-92 LAYOUT BOTTOM VIEW

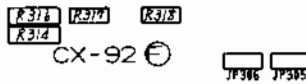
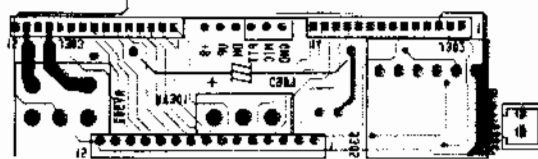
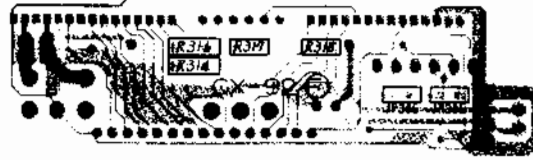

CX-92 LAYOUT TOP VIEW

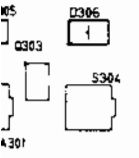
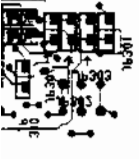
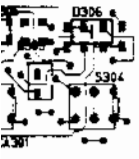
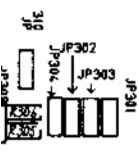
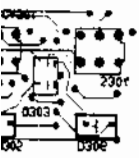
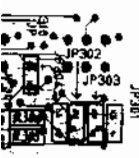
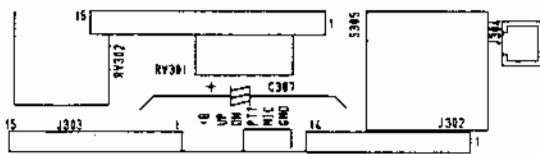
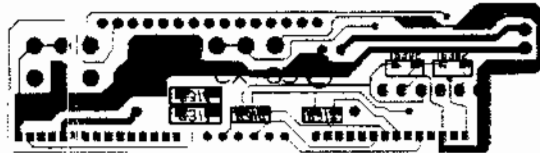
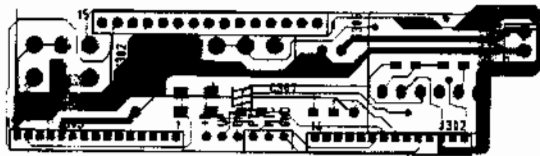

UNDER-DASH CONTROL HEAD SCHEMATIC

70-0351/0355

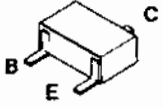
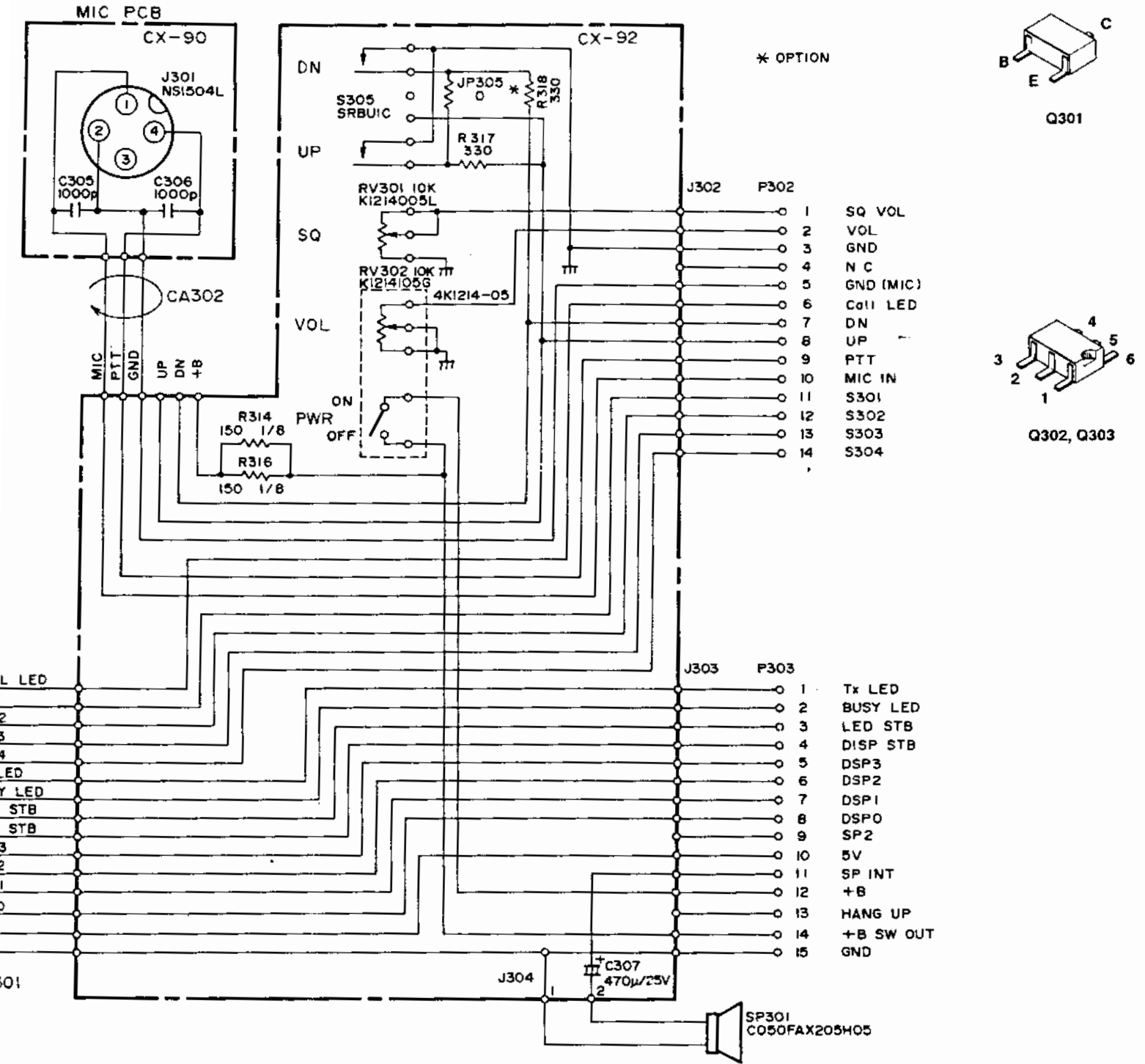

Q301

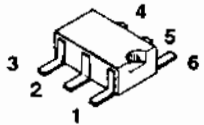

Q302, Q303

* OPTION

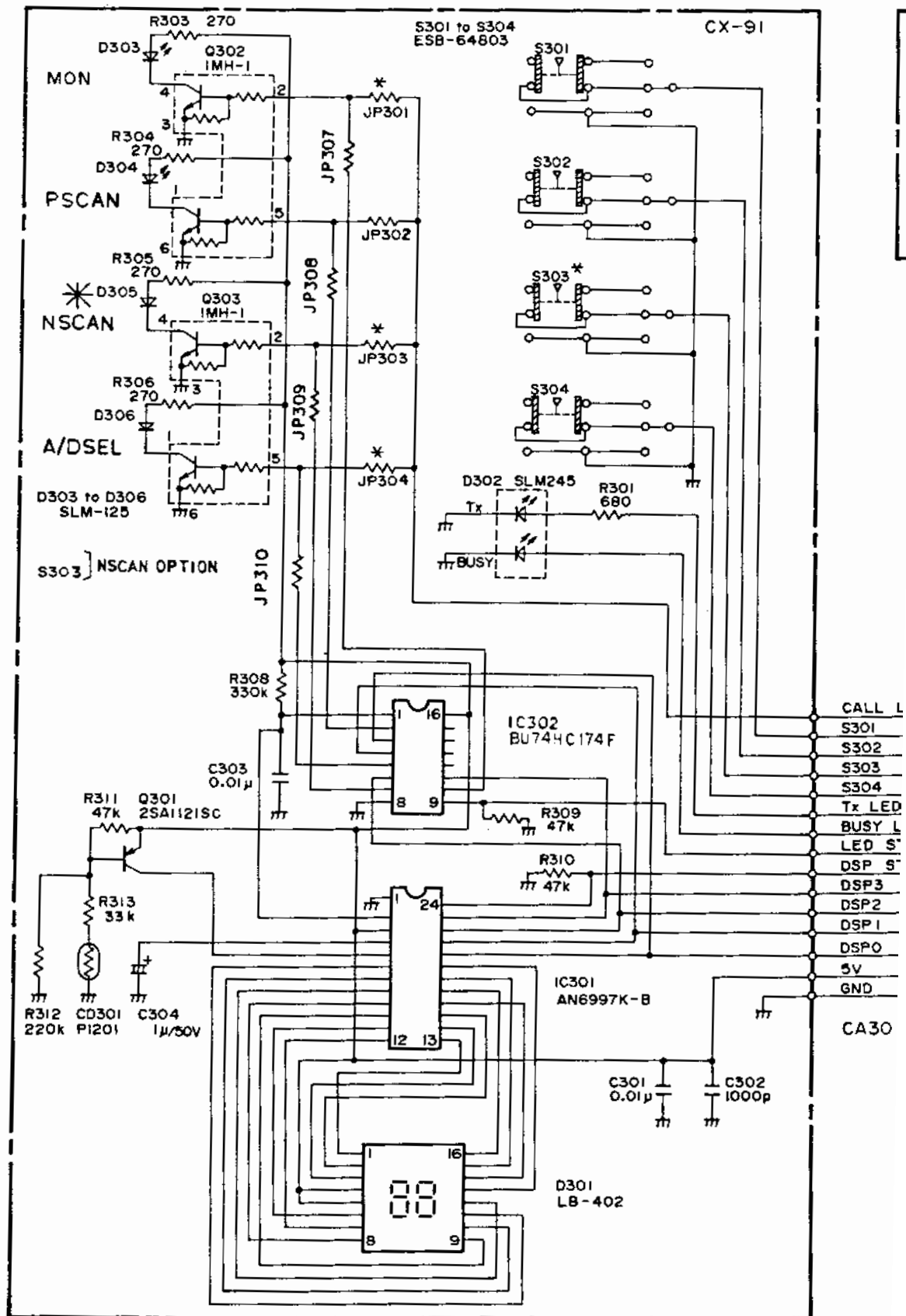

TRUNK-MOUNT CONTROL HEAD SCHEMATIC

70-0351/0355

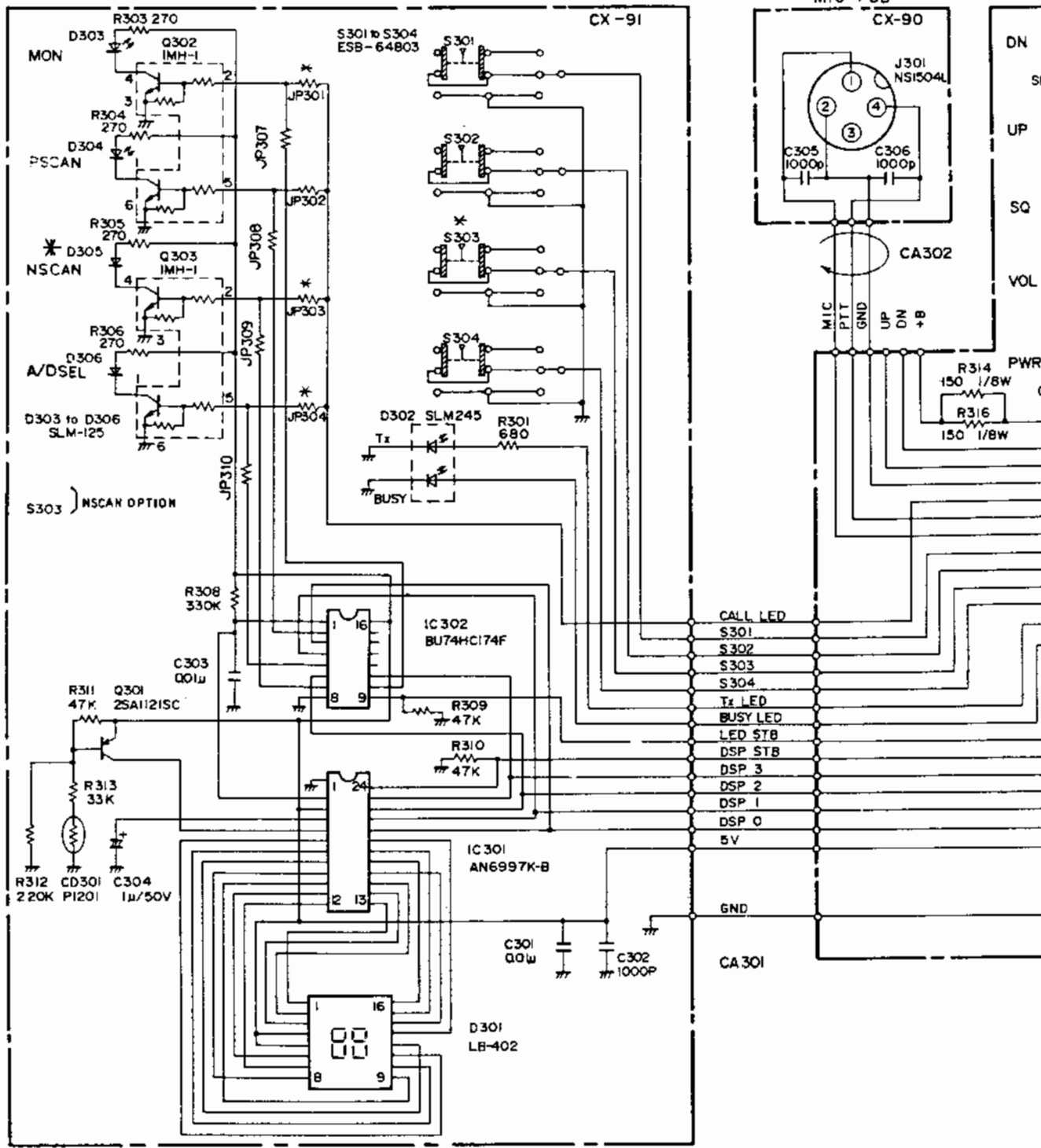
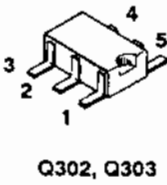
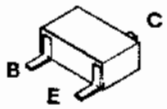

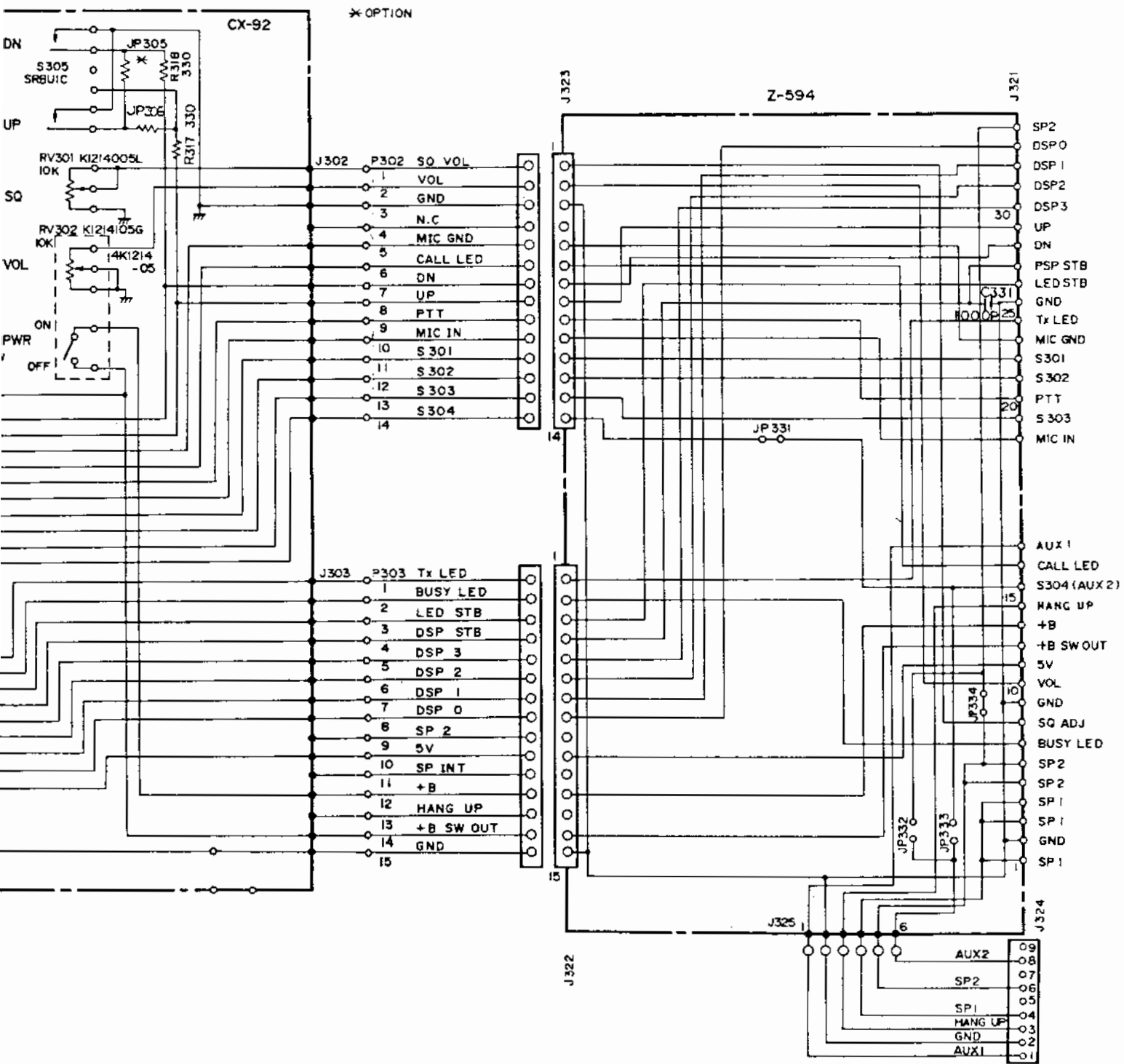

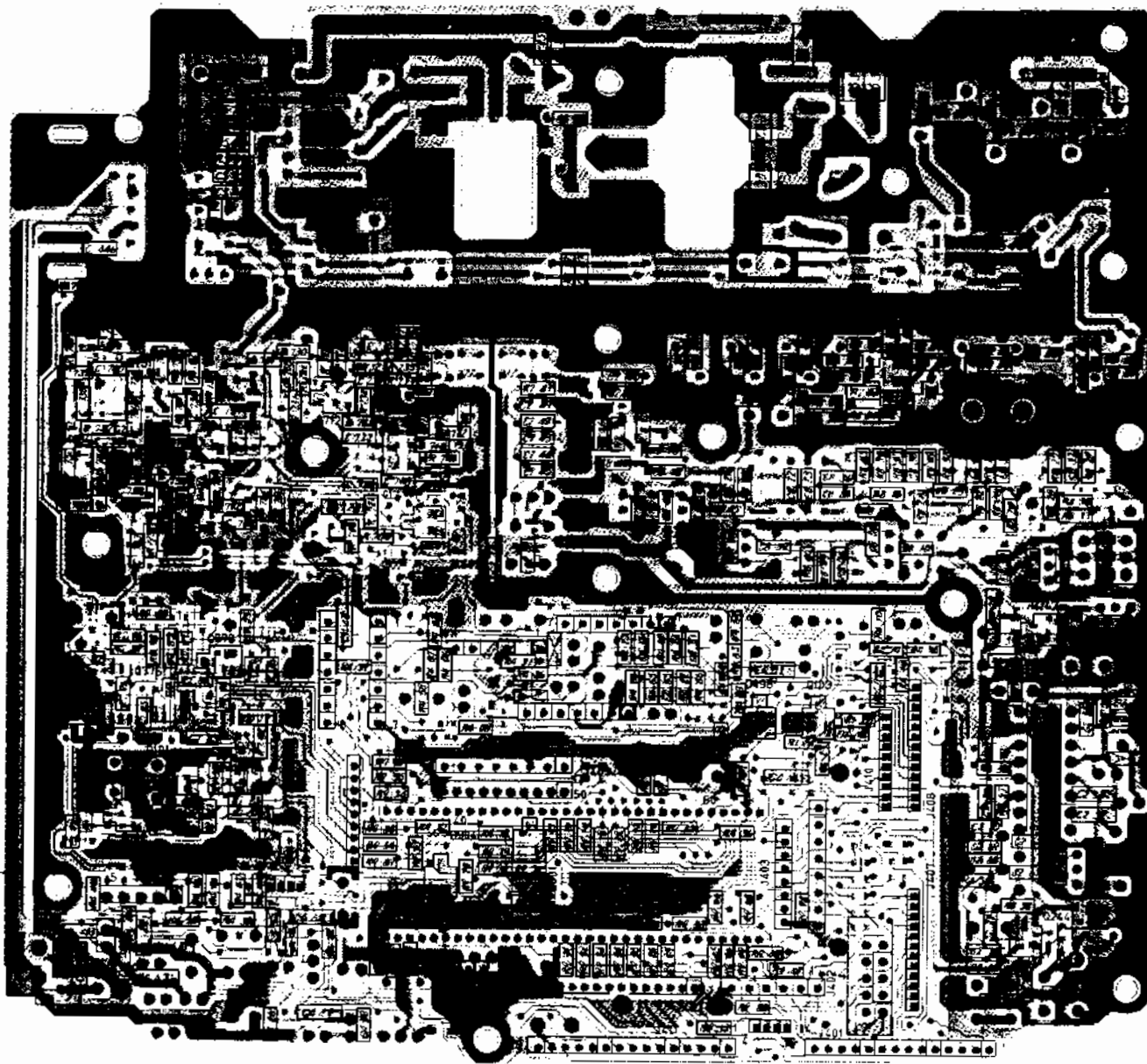

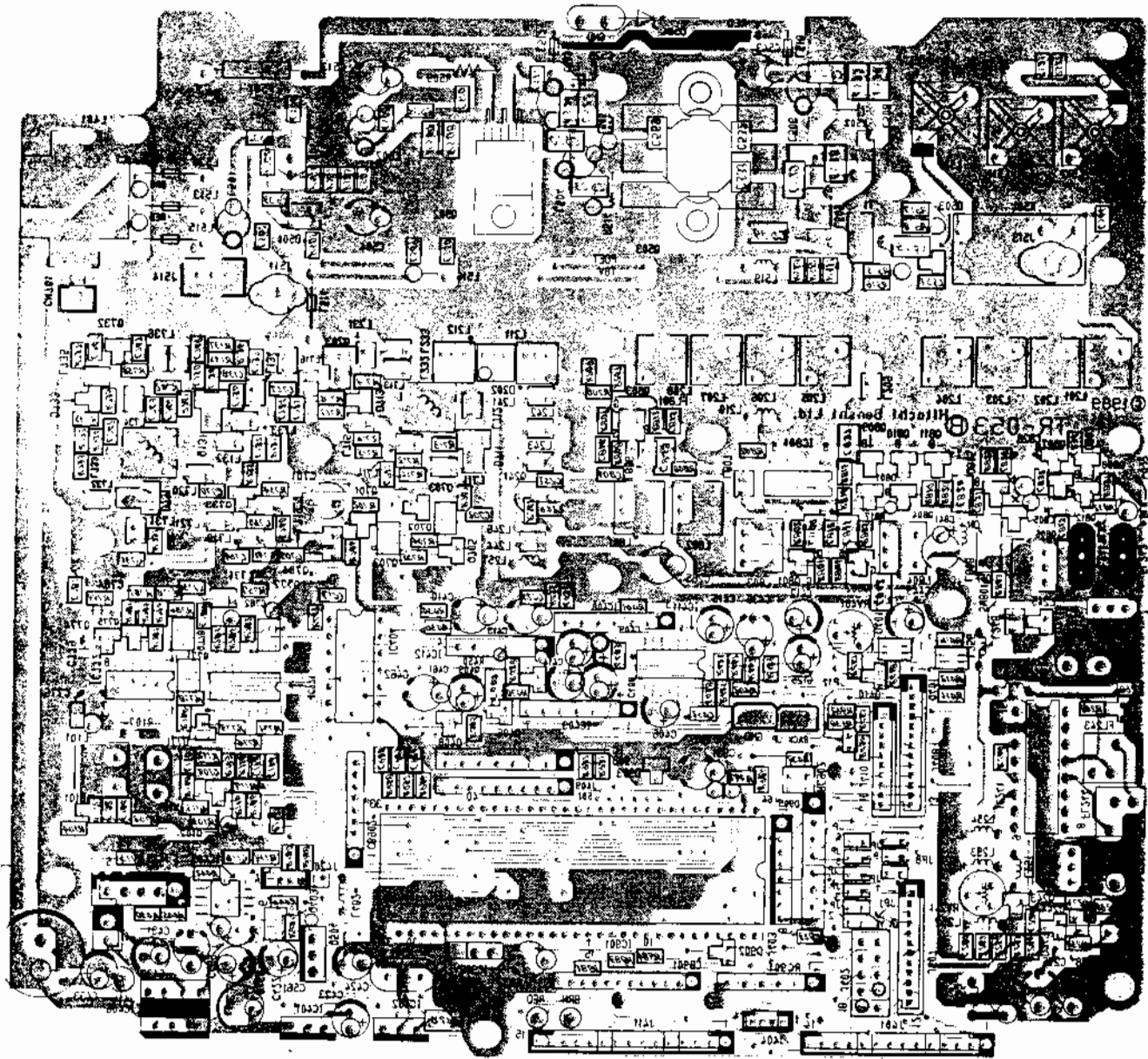

⊕

TR-053 LAYOUT--TOP VIEW

70-0351/0355

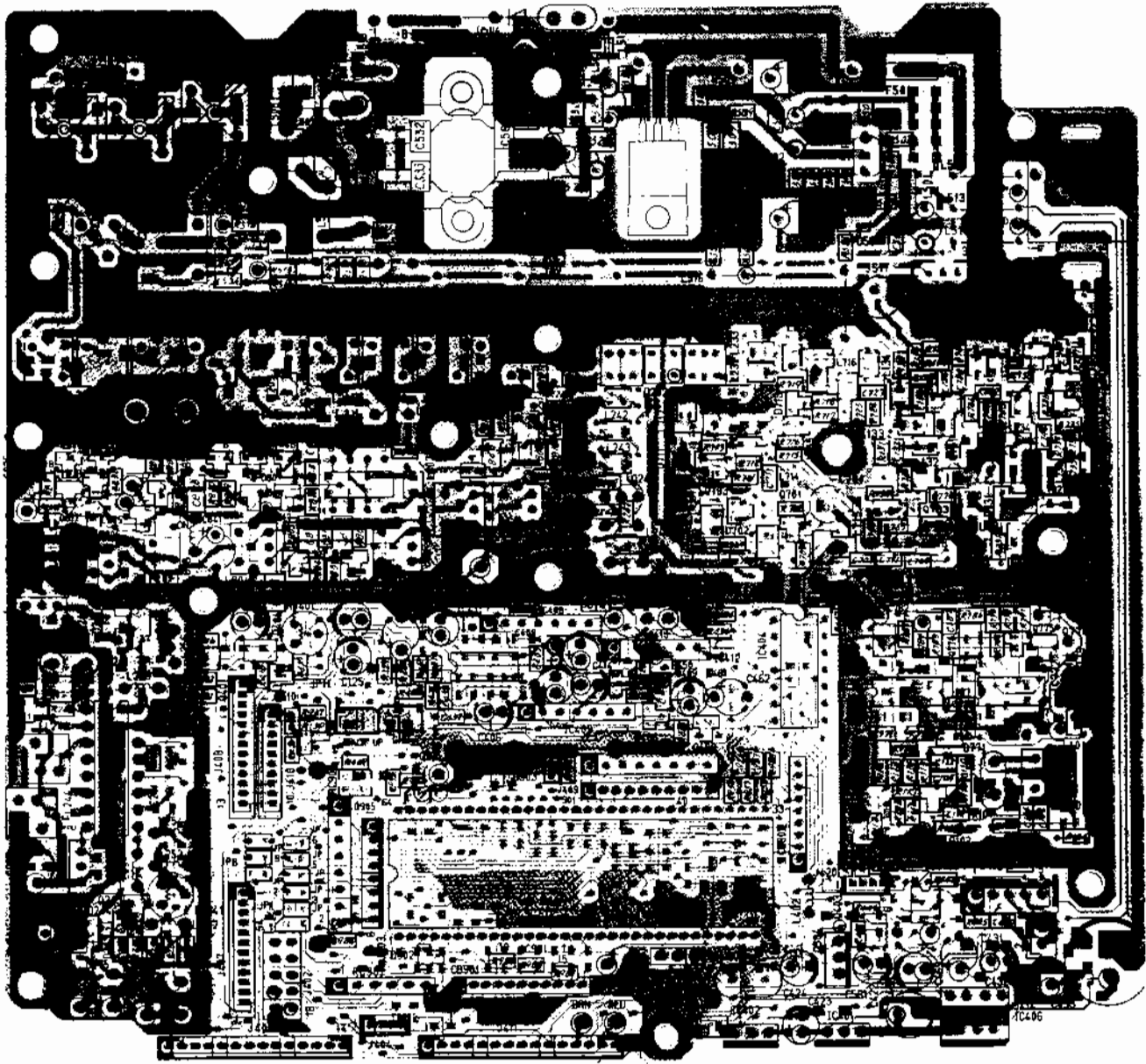

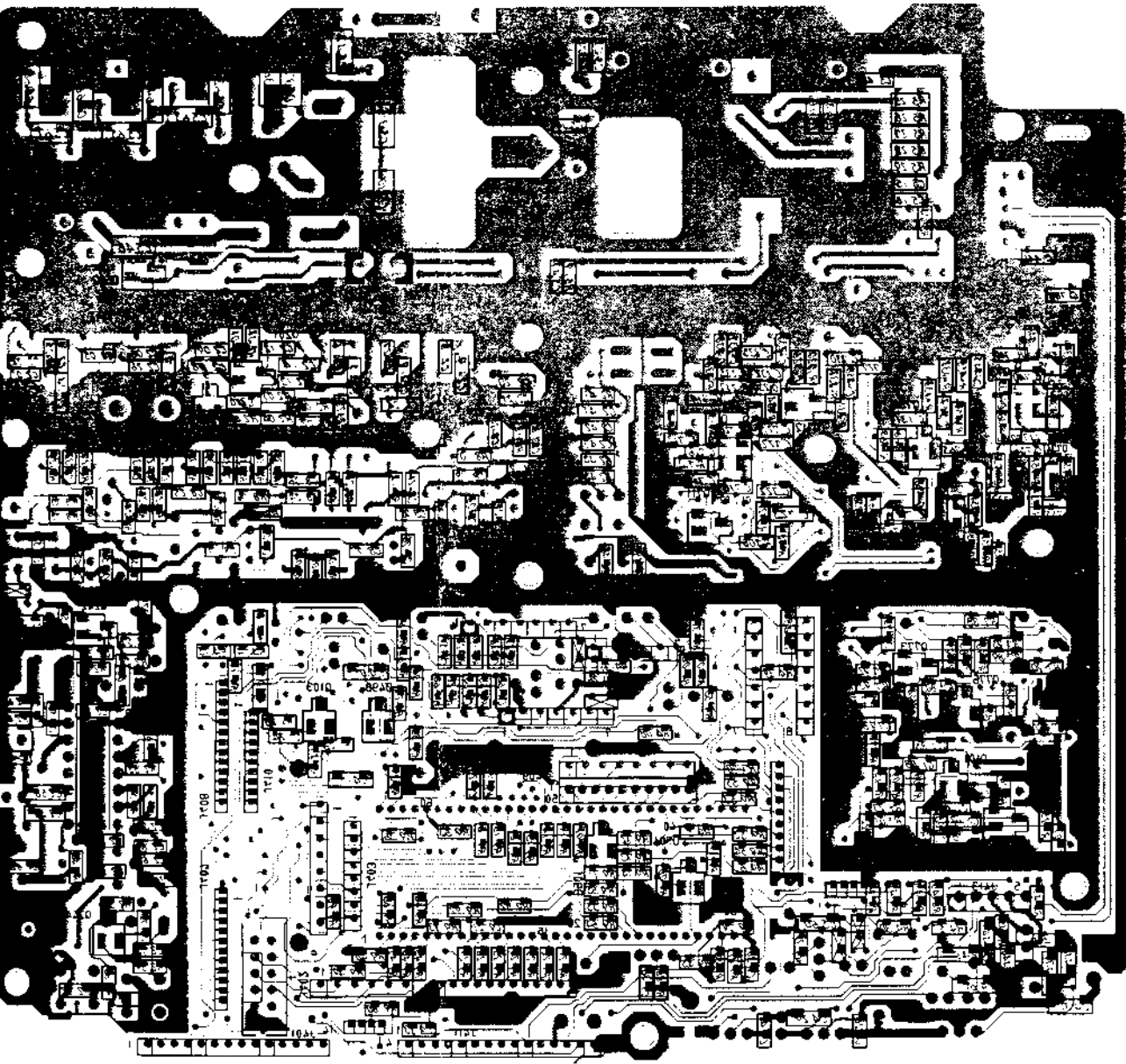

TR-053 SCHEMATIC DIAGRAM

70-0351/0355

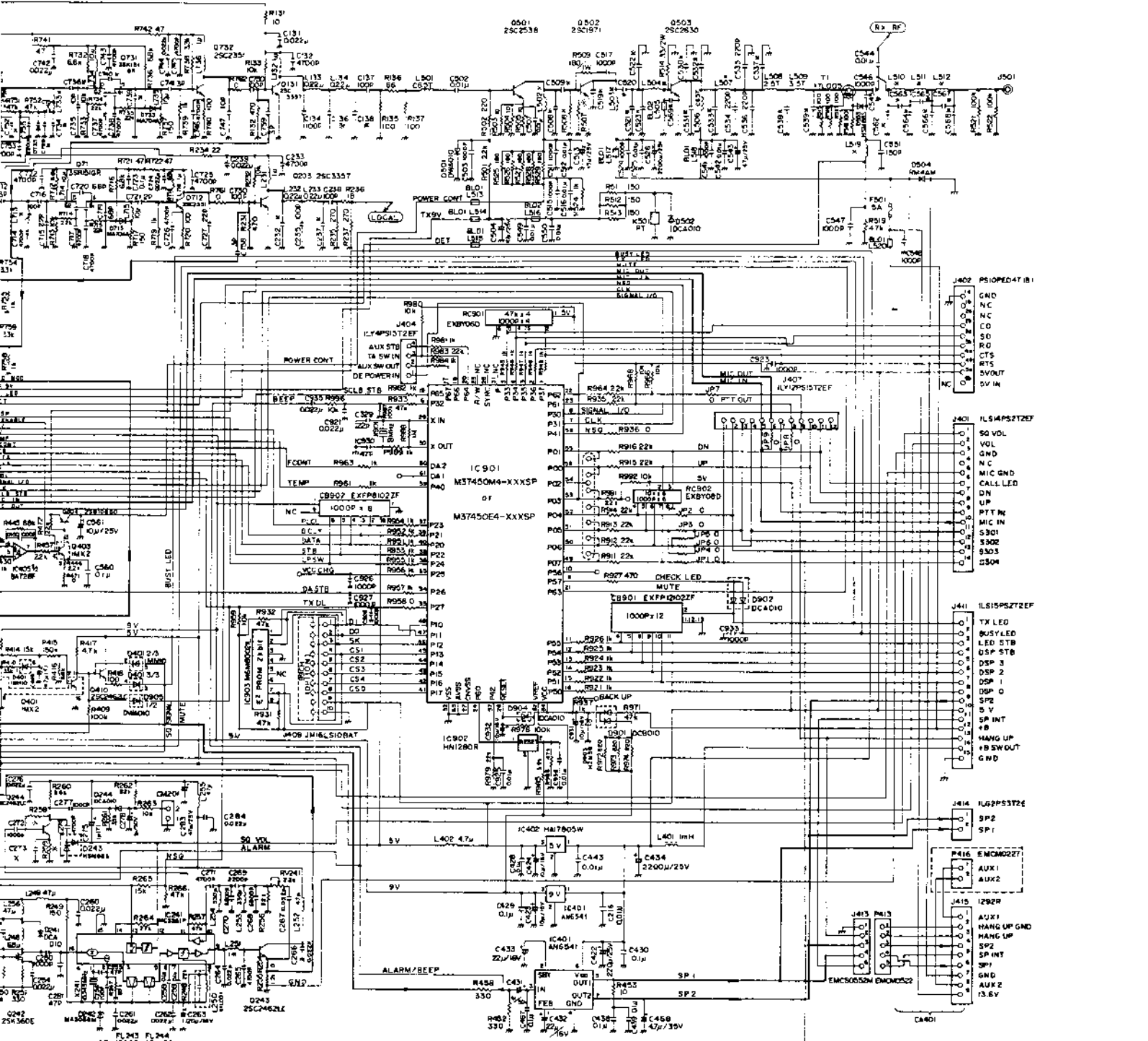

Pin No	C156	C158	C159	C160	C161	C162	C163	C164	C165	C166	C167	C168	C169	C170	C171	C172	C173	C174	C175	C176	C177	C178	C179	C180	C181	C182	C183	C184	C185	C186	C187	C188	C189	C190	C191	C192	C193	C194	C195	C196	C197	C198	C199	C200	C201	C202	C203	C204	C205	C206	C207	C208	C209	C210	C211	C212	C213	C214	C215	C216	C217	C218	C219	C220	C221	C222	C223	C224	C225	C226	C227	C228	C229	C230	C231	C232	C233	C234	C235	C236	C237	C238	C239	C240	C241	C242	C243	C244	C245	C246	C247	C248	C249	C250	C251	C252	C253	C254	C255	C256	C257	C258	C259	C260	C261	C262	C263	C264	C265	C266	C267	C268	C269	C270	C271	C272	C273	C274	C275	C276	C277	C278	C279	C280	C281	C282	C283	C284	C285	C286	C287	C288	C289	C290	C291	C292	C293	C294	C295	C296	C297	C298	C299	C300	C301	C302	C303	C304	C305	C306	C307	C308	C309	C310	C311	C312	C313	C314	C315	C316	C317	C318	C319	C320	C321	C322	C323	C324	C325	C326	C327	C328	C329	C330	C331	C332	C333	C334	C335	C336	C337	C338	C339	C340	C341	C342	C343	C344	C345	C346	C347	C348	C349	C350	C351	C352	C353	C354	C355	C356	C357	C358	C359	C360	C361	C362	C363	C364	C365	C366	C367	C368	C369	C370	C371	C372	C373	C374	C375	C376	C377	C378	C379	C380	C381	C382	C383	C384	C385	C386	C387	C388	C389	C390	C391	C392	C393	C394	C395	C396	C397	C398	C399	C400	C401	C402	C403	C404	C405	C406	C407	C408	C409	C410	C411	C412	C413	C414	C415	C416	C417	C418	C419	C420	C421	C422	C423	C424	C425	C426	C427	C428	C429	C430	C431	C432	C433	C434	C435	C436	C437	C438	C439	C440	C441	C442	C443	C444	C445	C446	C447	C448	C449	C450	C451	C452	C453	C454	C455	C456	C457	C458	C459	C460	C461	C462	C463	C464	C465	C466	C467	C468	C469	C470	C471	C472	C473	C474	C475	C476	C477	C478	C479	C480	C481	C482	C483	C484	C485	C486	C487	C488	C489	C490	C491	C492	C493	C494	C495	C496	C497	C498	C499	C500	C501	C502	C503	C504	C505	C506	C507	C508	C509	C510	C511	C512	C513	C514	C515	C516	C517	C518	C519	C520	C521	C522	C523	C524	C525	C526	C527	C528	C529	C530	C531	C532	C533	C534	C535	C536	C537	C538	C539	C540	C541	C542	C543	C544	C545	C546	C547	C548	C549	C550	C551	C552	C553	C554	C555	C556	C557	C558	C559	C560	C561	C562	C563	C564	C565	C566	C567	C568	C569	C570	C571	C572	C573	C574	C575	C576	C577	C578	C579	C580	C581	C582	C583	C584	C585	C586	C587	C588	C589	C590	C591	C592	C593	C594	C595	C596	C597	C598	C599	C600	C601	C602	C603	C604	C605	C606	C607	C608	C609	C610	C611	C612	C613	C614	C615	C616	C617	C618	C619	C620	C621	C622	C623	C624	C625	C626	C627	C628	C629	C630	C631	C632	C633	C634	C635	C636	C637	C638	C639	C640	C641	C642	C643	C644	C645	C646	C647	C648	C649	C650	C651	C652	C653	C654	C655	C656	C657	C658	C659	C660	C661	C662	C663	C664	C665	C666	C667	C668	C669	C670	C671	C672	C673	C674	C675	C676	C677	C678	C679	C680	C681	C682	C683	C684	C685	C686	C687	C688	C689	C690	C691	C692	C693	C694	C695	C696	C697	C698	C699	C700	C701	C702	C703	C704	C705	C706	C707	C708	C709	C710	C711	C712	C713	C714	C715	C716	C717	C718	C719	C720	C721	C722	C723	C724	C725	C726	C727	C728	C729	C730	C731	C732	C733	C734	C735	C736	C737	C738	C739	C740	C741	C742	C743	C744	C745	C746	C747	C748	C749	C750	C751	C752	C753	C754	C755	C756	C757	C758	C759	C760	C761	C762	C763	C764	C765	C766	C767	C768	C769	C770	C771	C772	C773	C774	C775	C776	C777	C778	C779	C780	C781	C782	C783	C784	C785	C786	C787	C788	C789	C790	C791	C792	C793	C794	C795	C796	C797	C798	C799	C800	C801	C802	C803	C804	C805	C806	C807	C808	C809	C810	C811	C812	C813	C814	C815	C816	C817	C818	C819	C820	C821	C822	C823	C824	C825	C826	C827	C828	C829	C830	C831	C832	C833	C834	C835	C836	C837	C838	C839	C840	C841	C842	C843	C844	C845	C846	C847	C848	C849	C850	C851	C852	C853	C854	C855	C856	C857	C858	C859	C860	C861	C862	C863	C864	C865	C866	C867	C868	C869	C870	C871	C872	C873	C874	C875	C876	C877	C878	C879	C880	C881	C882	C883	C884	C885	C886	C887	C888	C889	C890	C891	C892	C893	C894	C895	C896	C897	C898	C899	C900	C901	C902	C903	C904	C905	C906	C907	C908	C909	C910	C911	C912	C913	C914	C915	C916	C917	C918	C919	C920	C921	C922	C923	C924	C925	C926	C927	C928	C929	C930	C931	C932	C933	C934	C935	C936	C937	C938	C939	C940	C941	C942	C943	C944	C945	C946	C947	C948	C949	C950	C951	C952	C953	C954	C955	C956	C957	C958	C959	C960	C961	C962	C963	C964	C965	C966	C967	C968	C969	C970	C971	C972	C973	C974	C975	C976	C977	C978	C979	C980	C981	C982	C983	C984	C985	C986	C987	C988	C989	C990	C991	C992	C993	C994	C995	C996	C997	C998	C999	C1000
--------	------	------	------	------	------	------	------	------	------	------	------	------	------	------	------	------	------	------	------	------	------	------	------	------	------	------	------	------	------	------	------	------	------	------	------	------	------	------	------	------	------	------	------	------	------	------	------	------	------	------	------	------	------	------	------	------	------	------	------	------	------	------	------	------	------	------	------	------	------	------	------	------	------	------	------	------	------	------	------	------	------	------	------	------	------	------	------	------	------	------	------	------	------	------	------	------	------	------	------	------	------	------	------	------	------	------	------	------	------	------	------	------	------	------	------	------	------	------	------	------	------	------	------	------	------	------	------	------	------	------	------	------	------	------	------	------	------	------	------	------	------	------	------	------	------	------	------	------	------	------	------	------	------	------	------	------	------	------	------	------	------	------	------	------	------	------	------	------	------	------	------	------	------	------	------	------	------	------	------	------	------	------	------	------	------	------	------	------	------	------	------	------	------	------	------	------	------	------	------	------	------	------	------	------	------	------	------	------	------	------	------	------	------	------	------	------	------	------	------	------	------	------	------	------	------	------	------	------	------	------	------	------	------	------	------	------	------	------	------	------	------	------	------	------	------	------	------	------	------	------	------	------	------	------	------	------	------	------	------	------	------	------	------	------	------	------	------	------	------	------	------	------	------	------	------	------	------	------	------	------	------	------	------	------	------	------	------	------	------	------	------	------	------	------	------	------	------	------	------	------	------	------	------	------	------	------	------	------	------	------	------	------	------	------	------	------	------	------	------	------	------	------	------	------	------	------	------	------	------	------	------	------	------	------	------	------	------	------	------	------	------	------	------	------	------	------	------	------	------	------	------	------	------	------	------	------	------	------	------	------	------	------	------	------	------	------	------	------	------	------	------	------	------	------	------	------	------	------	------	------	------	------	------	------	------	------	------	------	------	------	------	------	------	------	------	------	------	------	------	------	------	------	------	------	------	------	------	------	------	------	------	------	------	------	------	------	------	------	------	------	------	------	------	------	------	------	------	------	------	------	------	------	------	------	------	------	------	------	------	------	------	------	------	------	------	------	------	------	------	------	------	------	------	------	------	------	------	------	------	------	------	------	------	------	------	------	------	------	------	------	------	------	------	------	------	------	------	------	------	------	------	------	------	------	------	------	------	------	------	------	------	------	------	------	------	------	------	------	------	------	------	------	------	------	------	------	------	------	------	------	------	------	------	------	------	------	------	------	------	------	------	------	------	------	------	------	------	------	------	------	------	------	------	------	------	------	------	------	------	------	------	------	------	------	------	------	------	------	------	------	------	------	------	------	------	------	------	------	------	------	------	------	------	------	------	------	------	------	------	------	------	------	------	------	------	------	------	------	------	------	------	------	------	------	------	------	------	------	------	------	------	------	------	------	------	------	------	------	------	------	------	------	------	------	------	------	------	------	------	------	------	------	------	------	------	------	------	------	------	------	------	------	------	------	------	------	------	------	------	------	------	------	------	------	------	------	------	------	------	------	------	------	------	------	------	------	------	------	------	------	------	------	------	------	------	------	------	------	------	------	------	------	------	------	------	------	------	------	------	------	------	------	------	------	------	------	------	------	------	------	------	------	------	------	------	------	------	------	------	------	------	------	------	------	------	------	------	------	------	------	------	------	------	------	------	------	------	------	------	------	------	------	------	------	------	------	------	------	------	------	------	------	------	------	------	------	------	------	------	------	------	------	------	------	------	------	------	------	------	------	------	------	------	------	------	------	------	------	------	------	------	------	------	------	------	------	------	------	------	------	------	------	------	------	------	------	------	------	------	------	------	------	------	------	------	------	------	------	------	------	------	------	------	------	------	------	------	------	------	------	------	------	------	------	------	------	------	------	------	------	------	------	------	------	------	------	------	------	------	------	------	------	------	------	------	------	------	------	------	------	------	------	------	------	------	------	------	------	------	------	------	------	------	------	------	------	------	------	------	------	------	------	------	-------

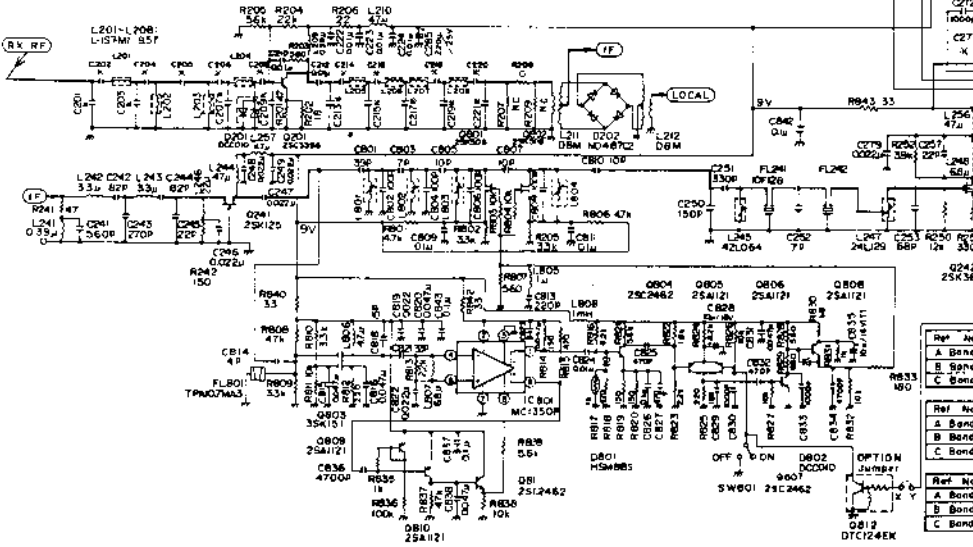
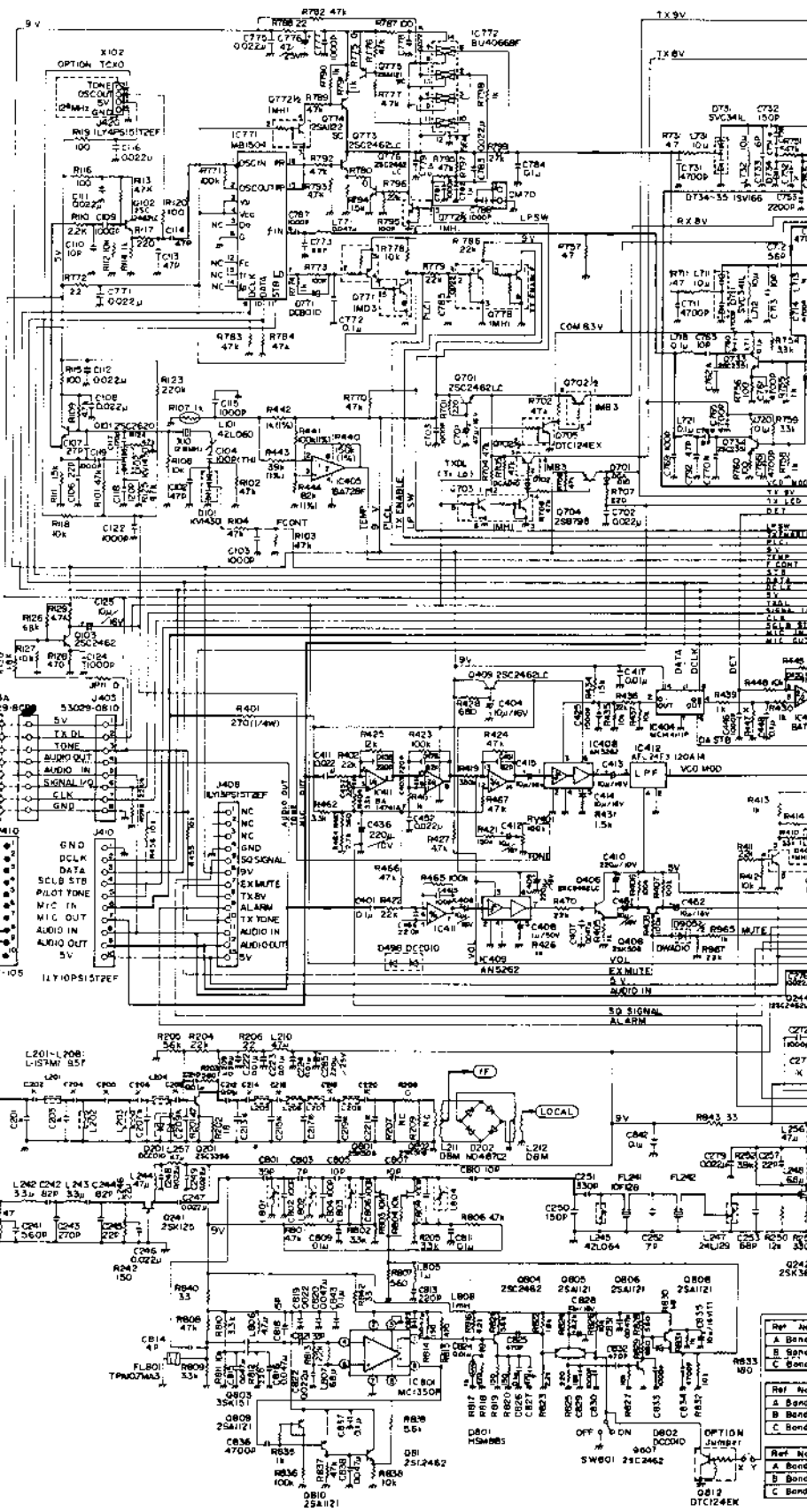

Ref No	Ref No
A Band	A Band
B Band	B Band
C Band	C Band
Ref No	Ref No
A Band	A Band
B Band	B Band
C Band	C Band

TR-053 COMPONENT LAYOUT

70-0351/0355

TOP VIEW

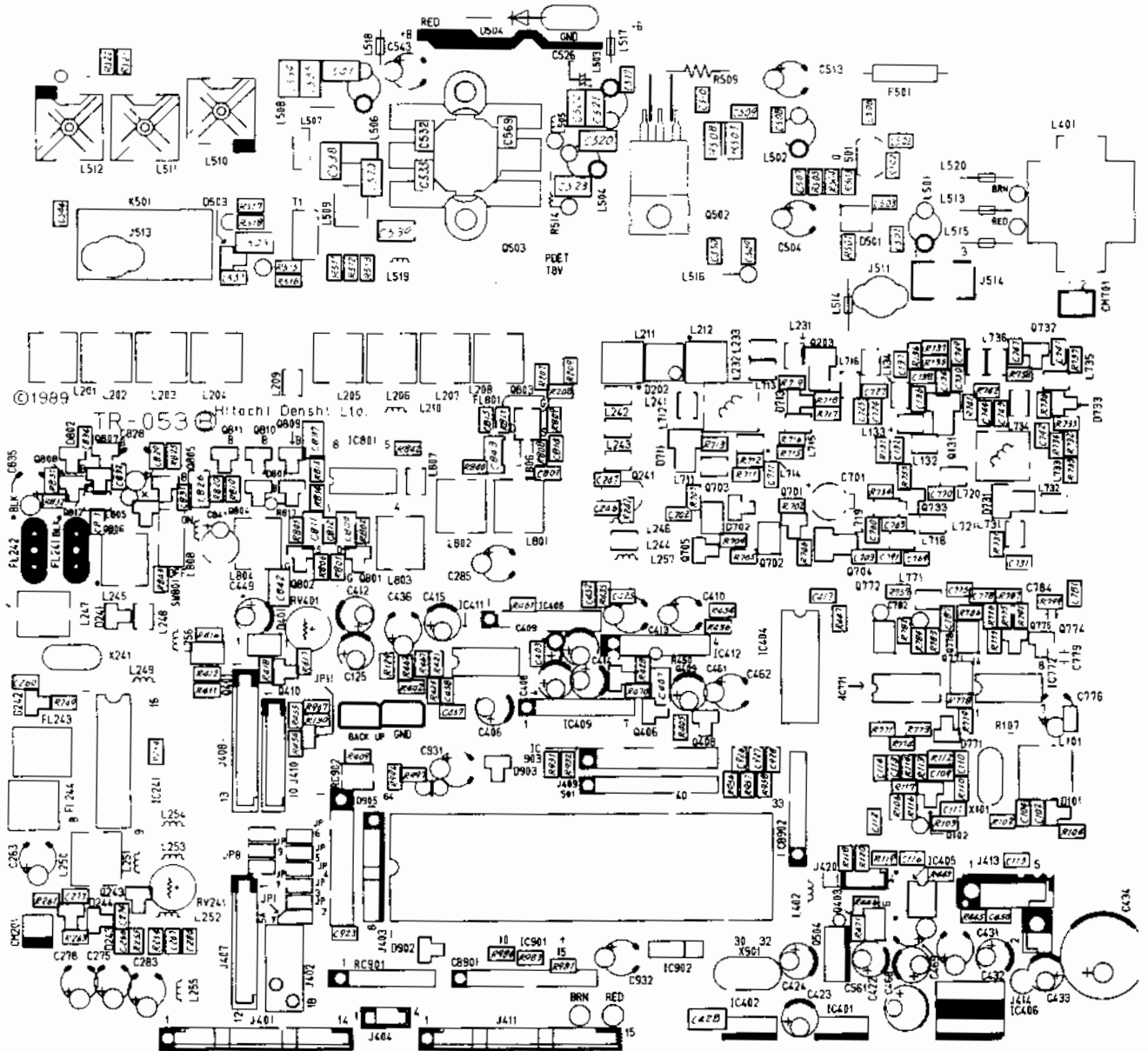

BOTTOM VIEW

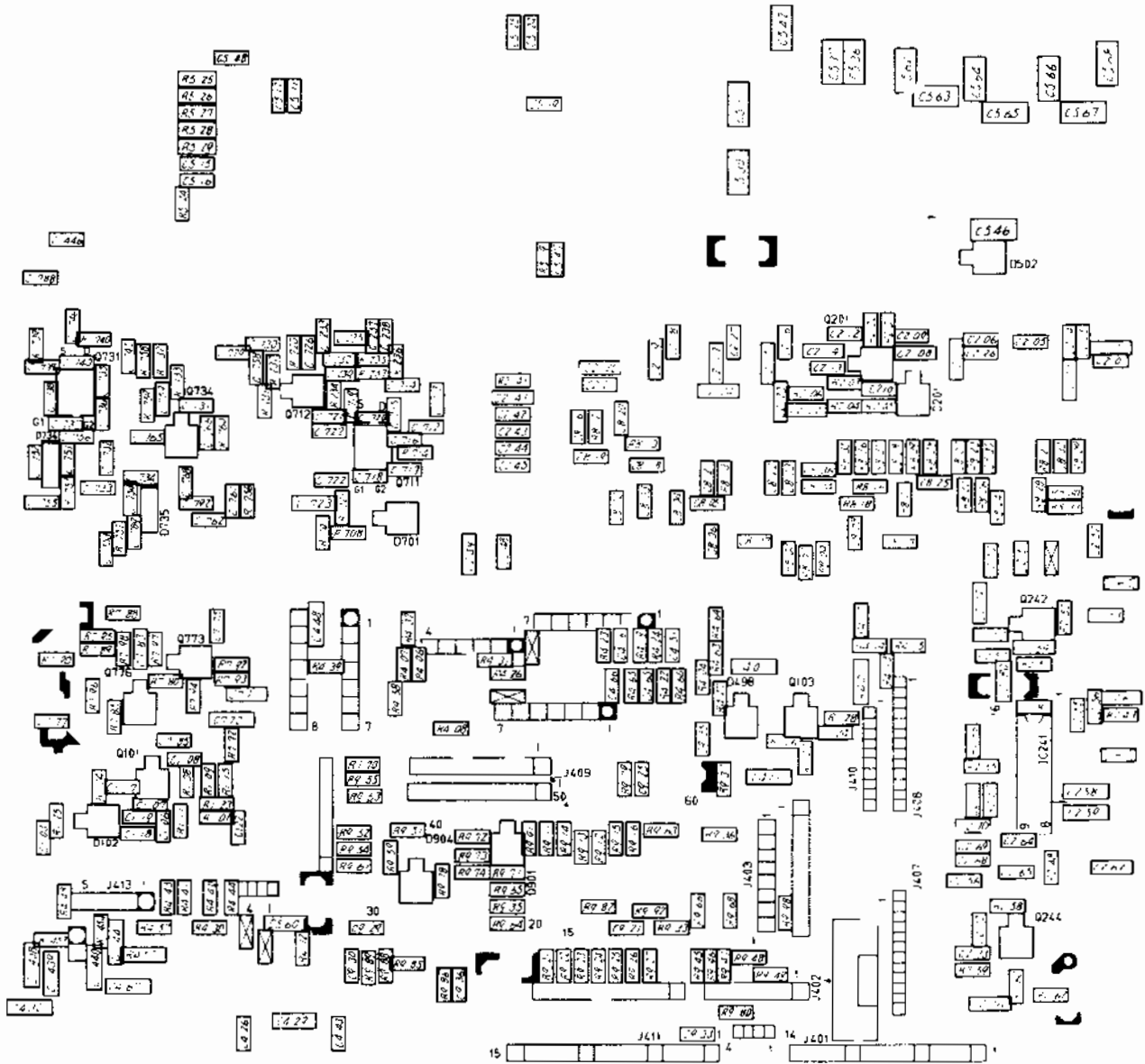

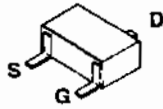

Q242

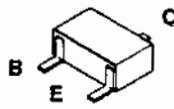

Q101, Q102, Q103, Q201,
Q243, Q244, Q406, Q409,
Q410, Q701, Q704, Q705,
Q712, Q732, Q733, Q734,
Q773, Q774, Q775, Q776,
Q804, Q805, Q806, Q807,
Q808, Q809, Q810, Q811,
Q812

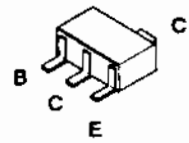

Q131, Q203, Q704

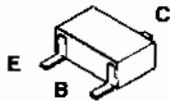

Q408, Q702

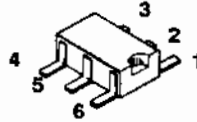

Q401, Q403, Q703,
Q771, Q772, Q778

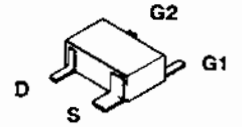

Q711, Q731, Q803



Q241

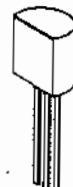

Q501



Q502

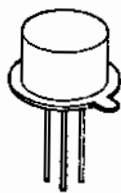

Q503



Q504

TR-053 DIODE PINOUTS

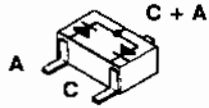

D201, D243, D502, D801

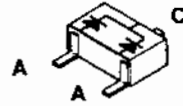

D101, D102, D713,
D733, D771, D904



D903

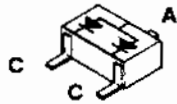

D241, D244, D502, D701,
D702, D711, D731, D902,
D904

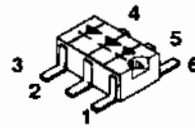

D401

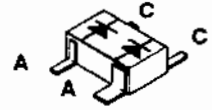

D501, D905

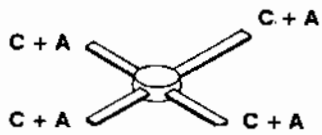

D202

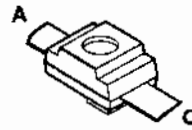

D734, D735

70-2157 CTCSS FILTER BOARD SCHEMATIC

70-0351/0355

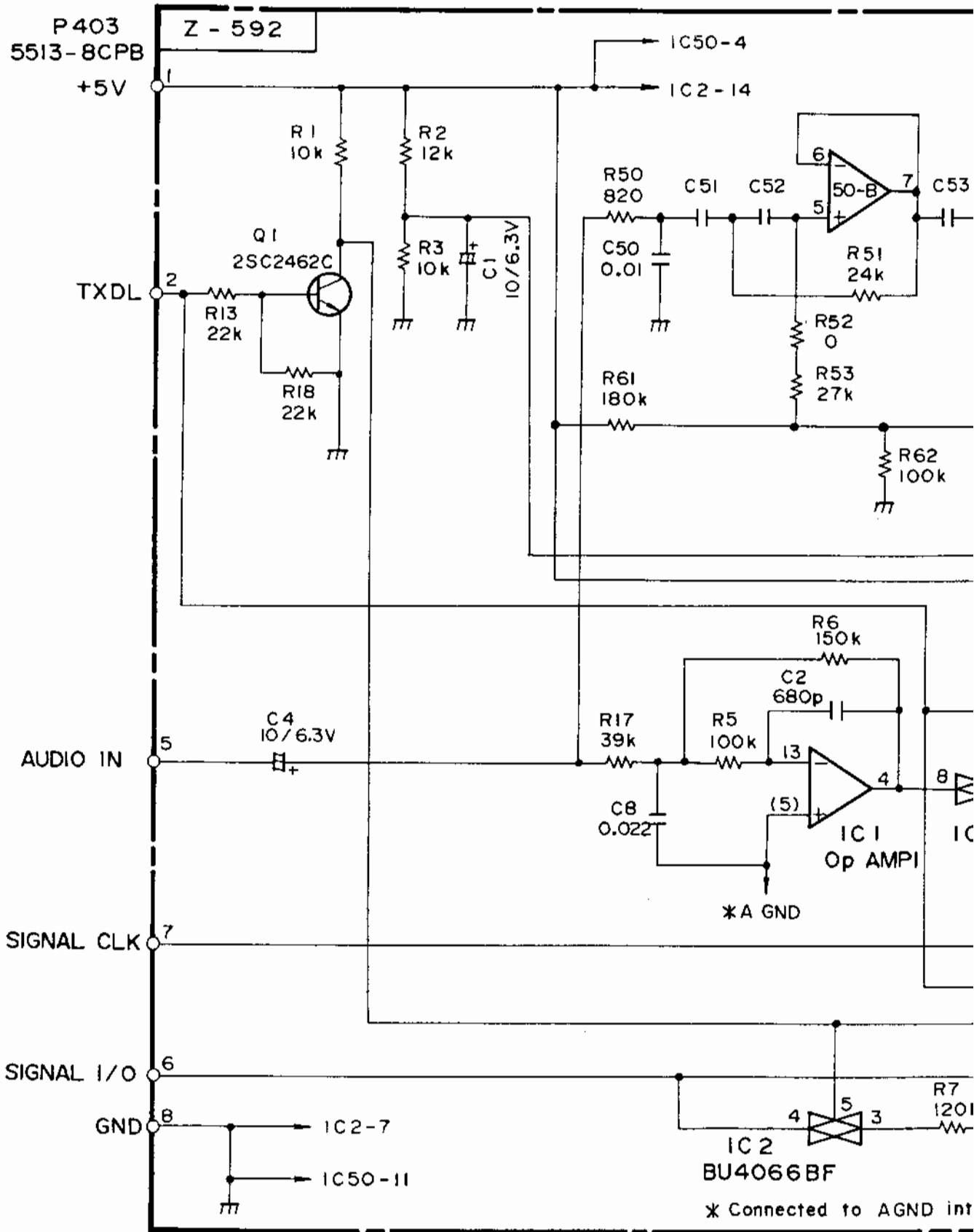
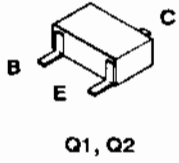

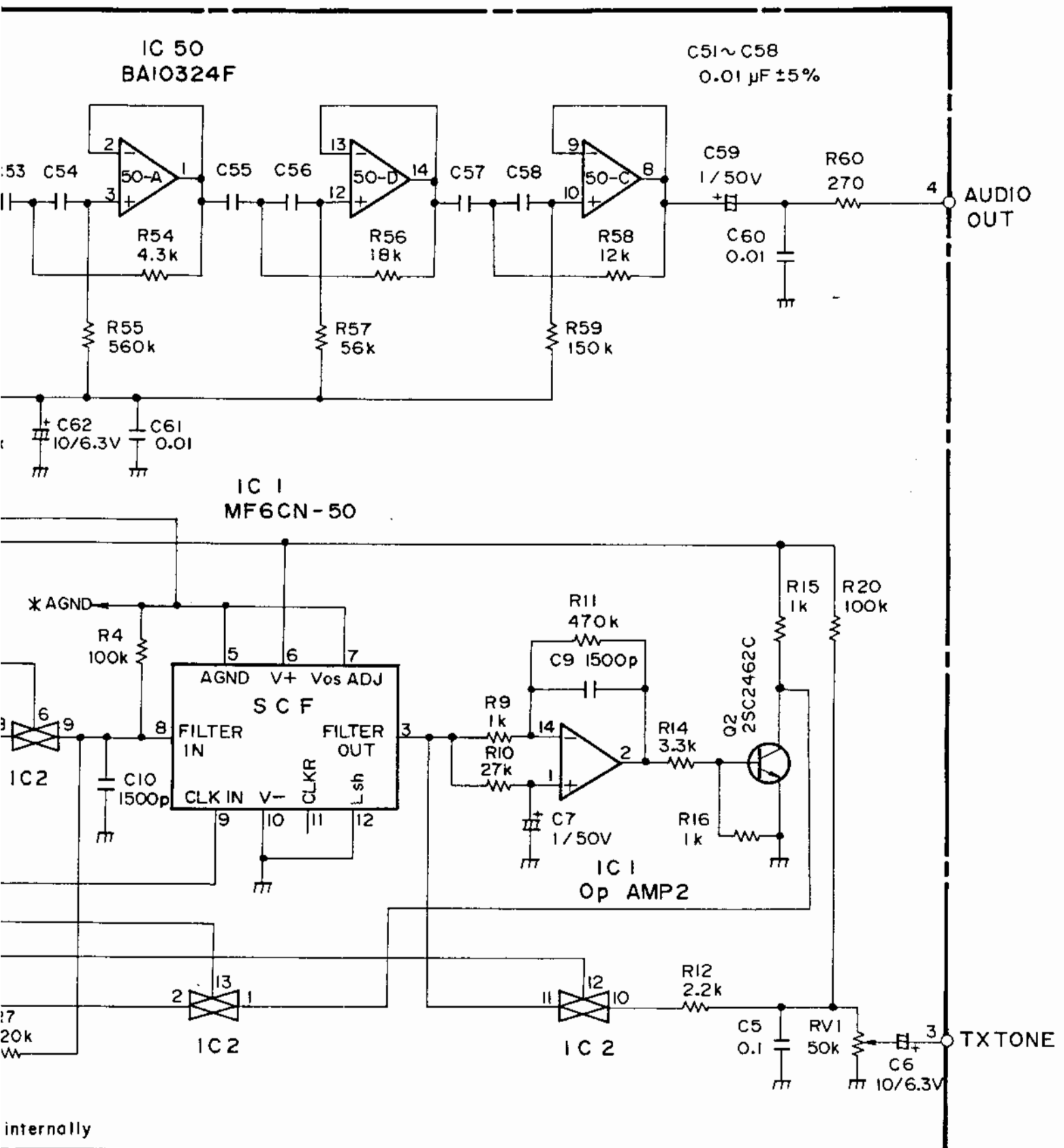

70-2157 CTCSS FILTER BOARD LAYOUT

70-0351/0355



BOTTOM VIEW

TOP VIEW

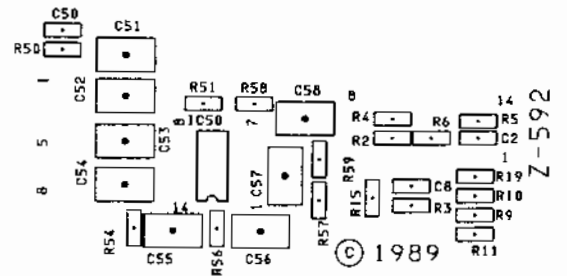
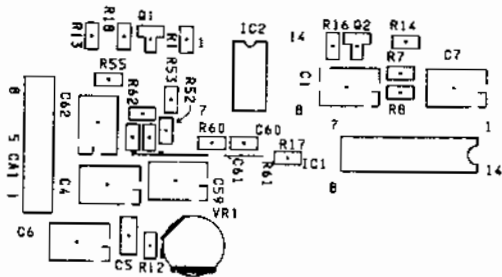
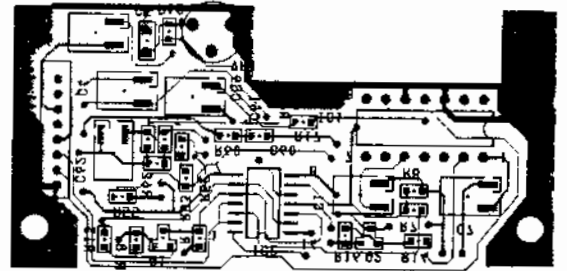
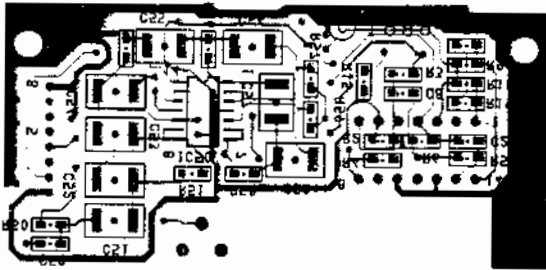
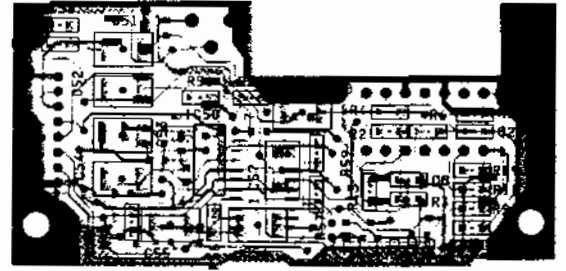
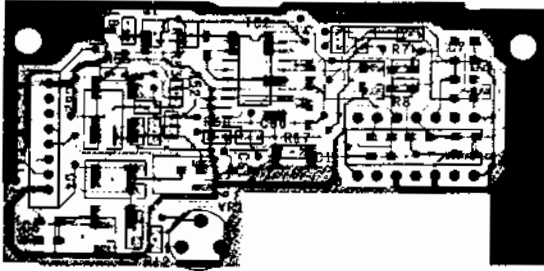

Z-594 LAYOUT

TOP VIEW

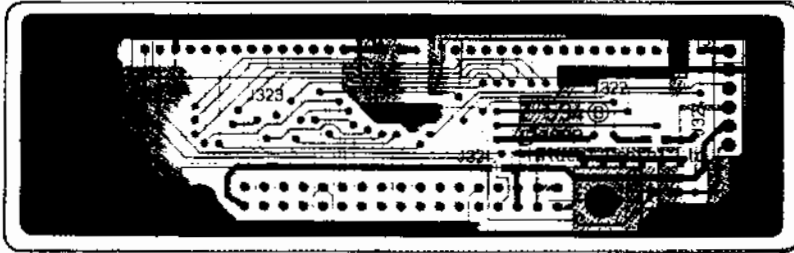

BOTTOM VIEW

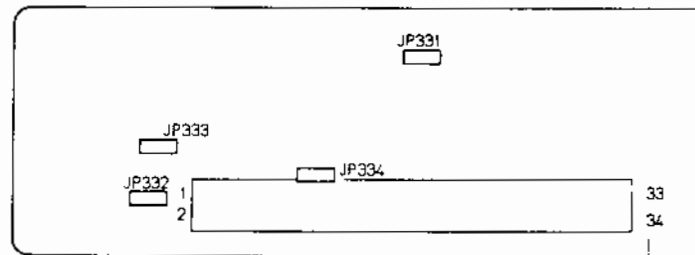
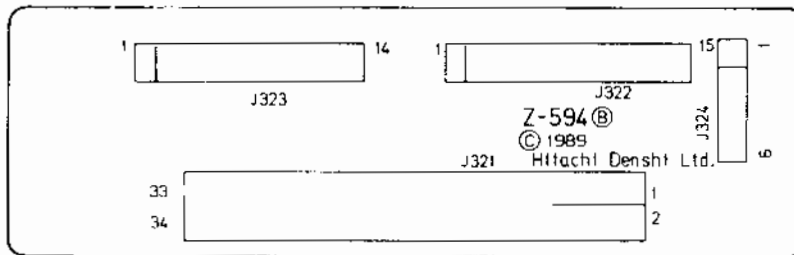
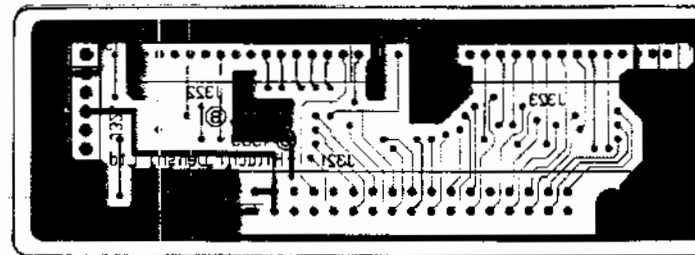
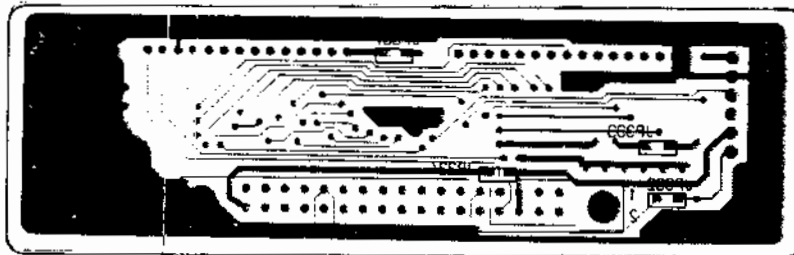
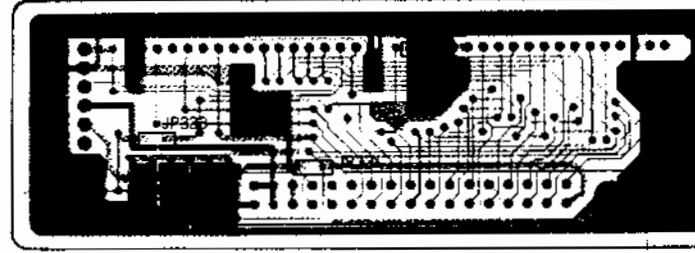

Z-593 TRUNK-MOUNT INTERFACE SCHEMATIC

70-0351/0355

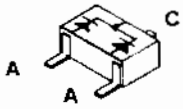

D311

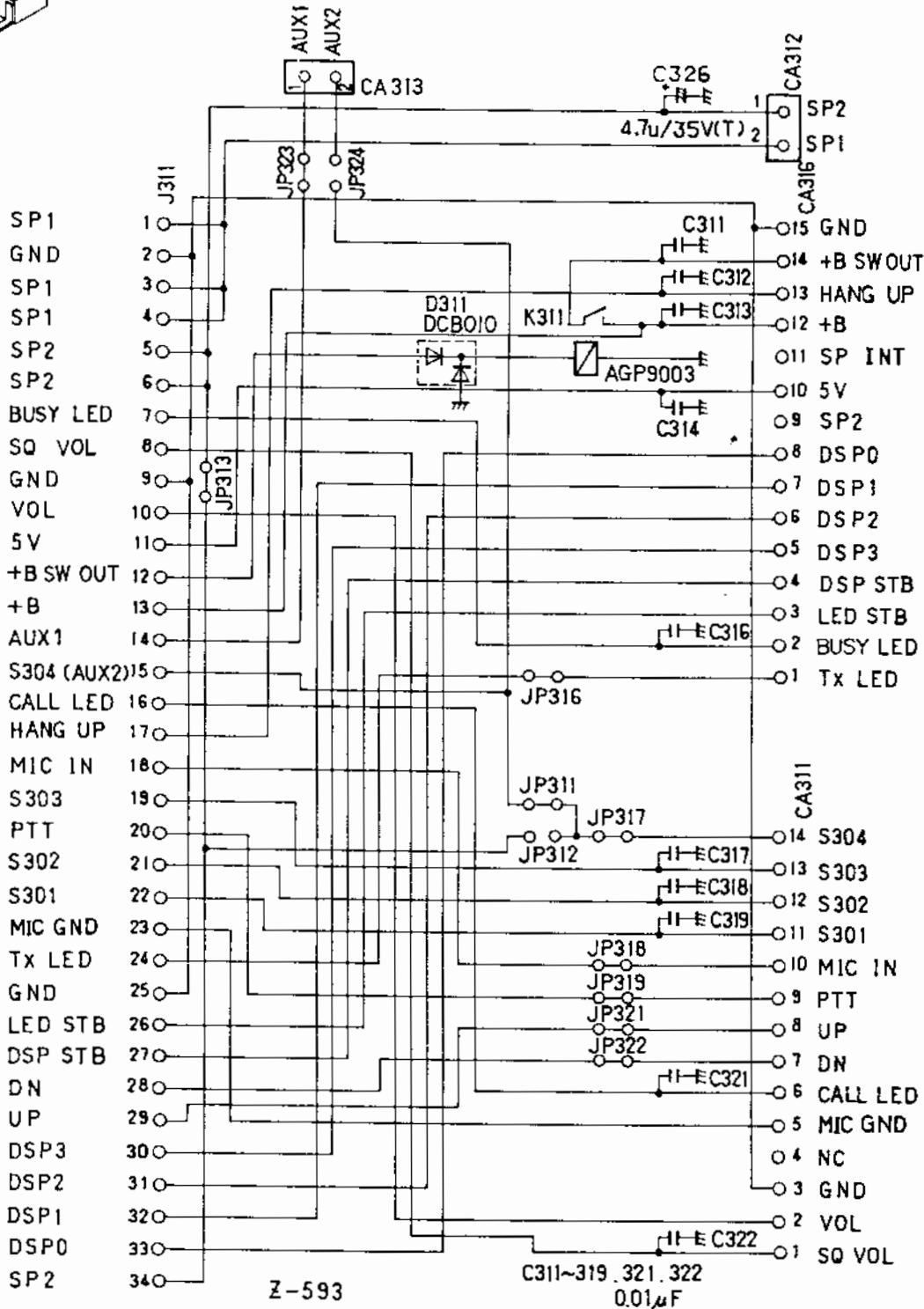



BOTTOM VIEW

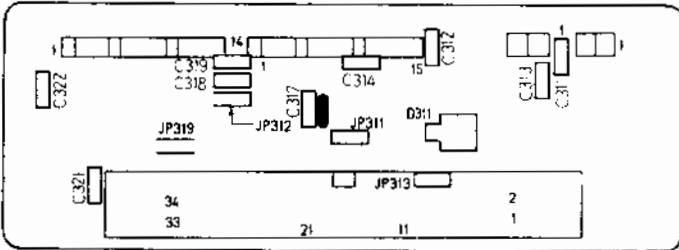
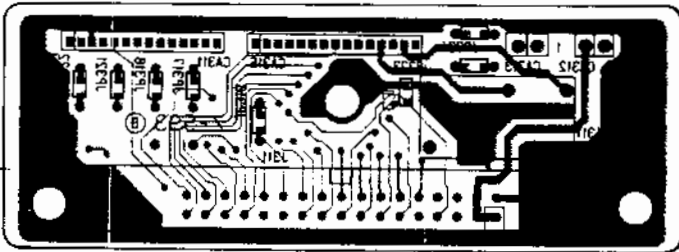
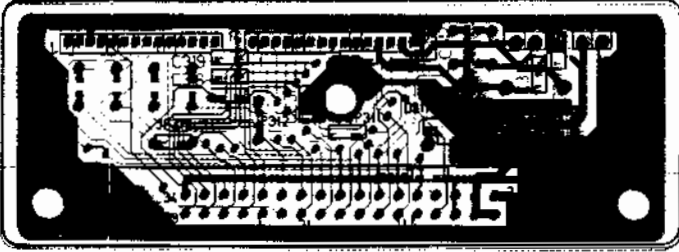

TOP VIEW

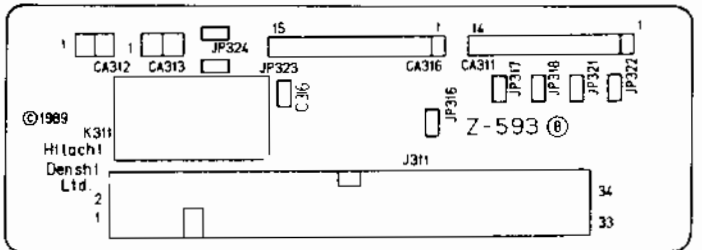
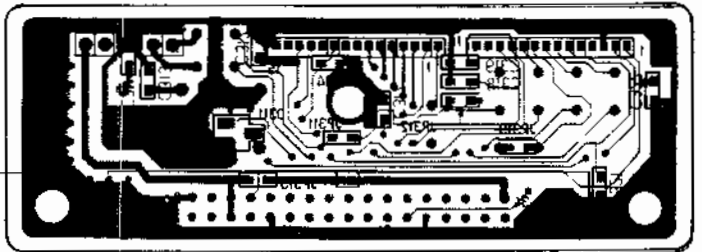
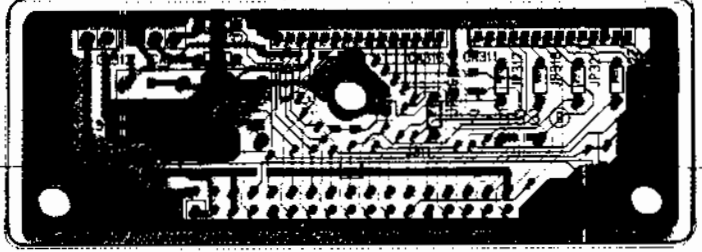

UNDER-DASH EXPLODED VIEW

70-0351/0355

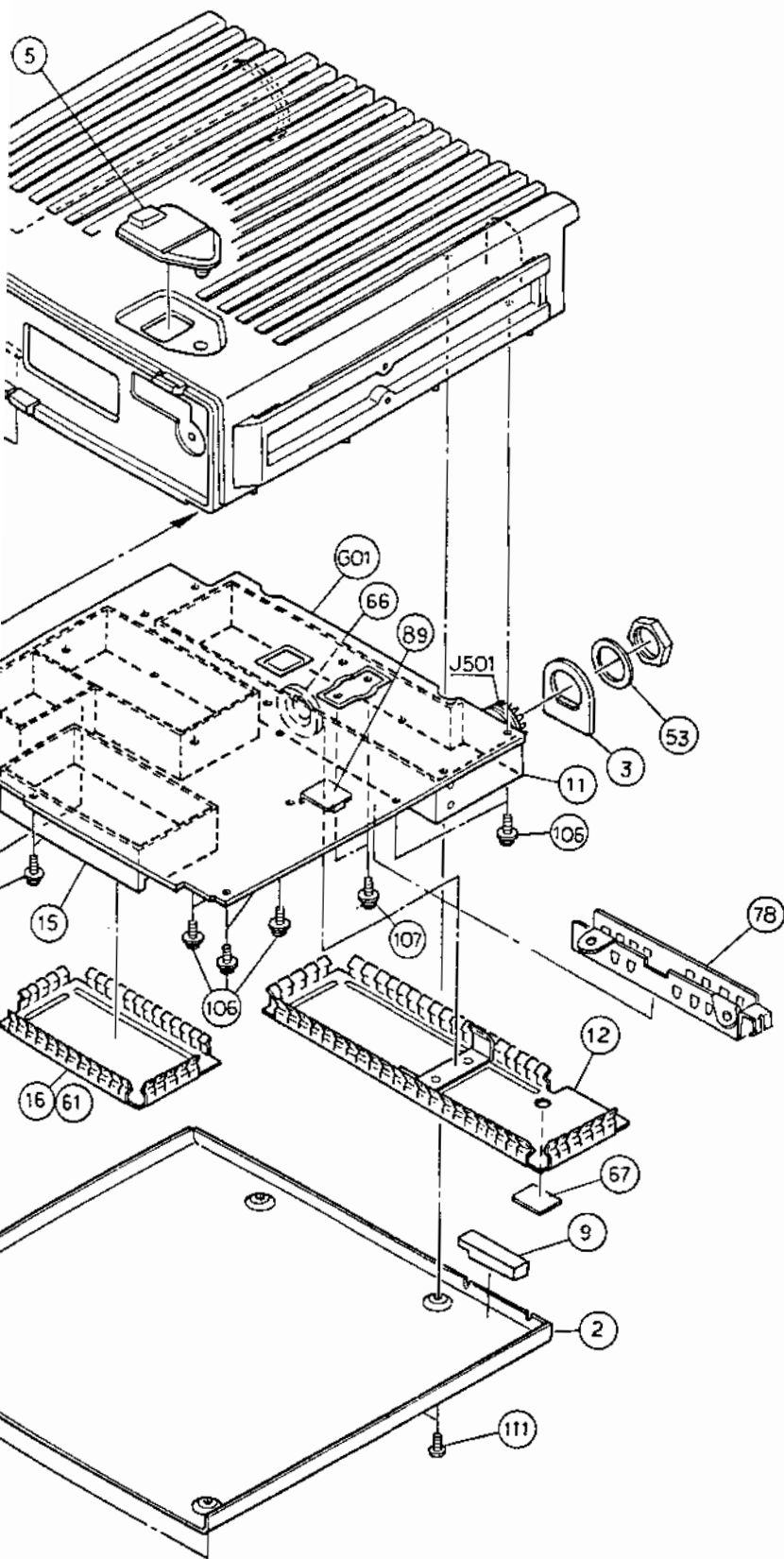

REF NO.	DESCRIPTION	PART NO.
1	CHASSIS	70-010281
2	COVER	70-010282
3	ANT PANEL	70-010313
4	CLIP	70-150126
5	PROGRAMMER PORT PACKING	70-157358
9	DUST PACKING	70-157428
11	PA SHIELD CASE	70-089345
12	PA SHIELD COVER	70-089340
13	VCO SHIELD CASE	70-089341
14	VCO SHIELD COVER	70-089342
15	LOG SHIELD CASE	70-089343
16	LOG SHIELD COVER	70-089344
22	FRONT COVER ASSY	70-010289
23	SPEAKER BRACKET	70-158324
24	VOLUME KNOB	70-110066
25	VOLUME KNOB	70-110067
26	SWITCH BUTTON	70-110065
39	PCB GUIDE	70-158354
40	VOLUME BRACKET	70-158328
42	LED SPACER	70-150133
50	BRACKET ASSY	70-158327
53	WASHER	70-150150
61	INSULATOR	70-157409
88	RING	70-150148
78	FE GROUND SPRING	70-152123
89	IF SHIELD	70-089366
101	SCREW PLAX PAN HD M3 x 10	70-150138
106	SCREW SEMS M3 x 10	70-150180
107	SCREW SEMS M3 x 12	70-150151
109	FIXED SCREW PACK	70-000012
111	SCREW BIND HD M3 x 8	70-150146
CA401	CABLE ASSEMBLY	70-034094
J301	NS1504L	70-158100
J501	M-PM	70-156090
SP301	SPEAKER	70-080033
G01	TRX. LOGIC PCB	TR-053
G02	MIC CONNECTOR PCB	CX-90
G03	DISPLAY PCB	CX-91
G04	OPERATE PCB	CX-92

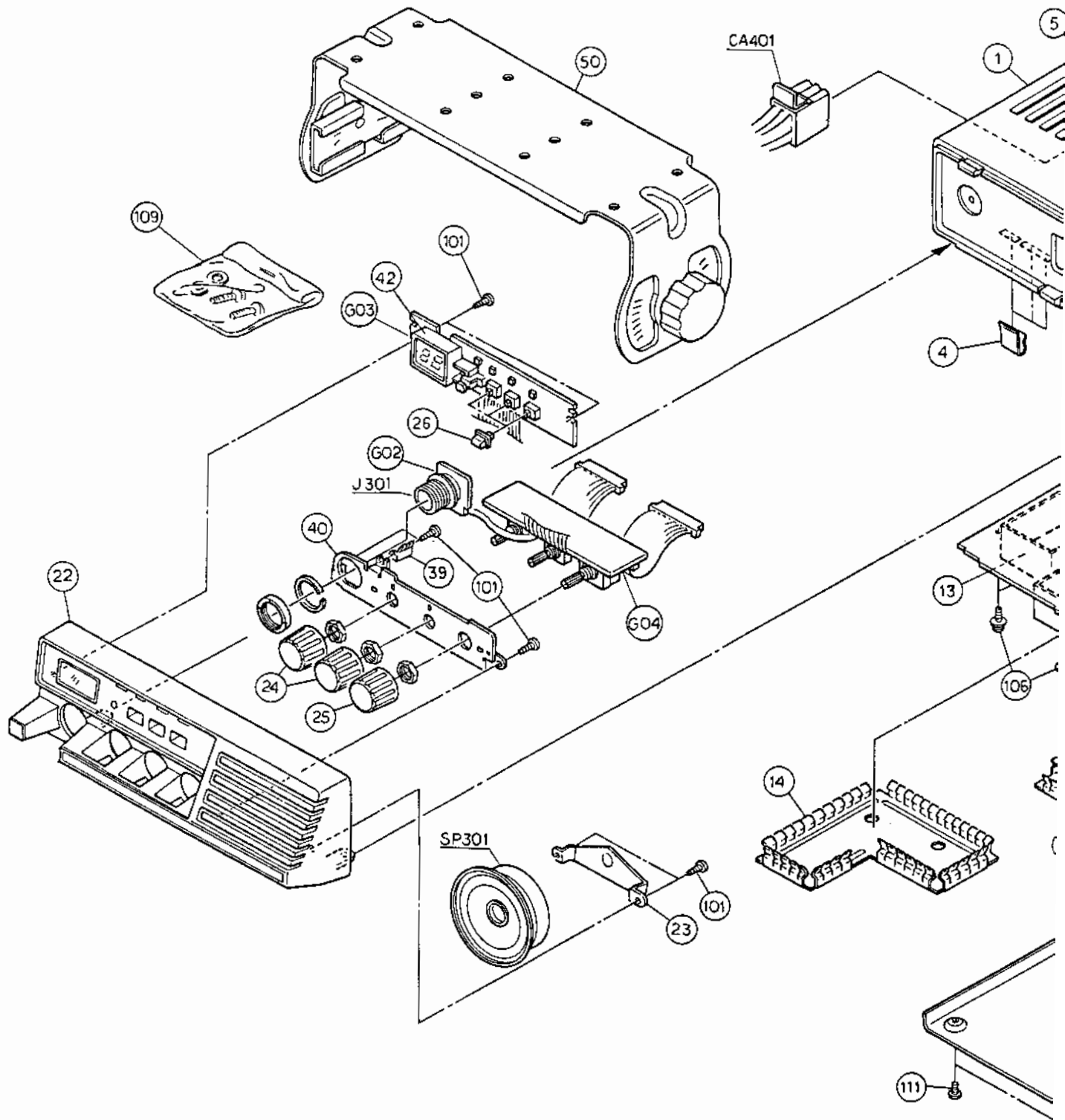

TRUNK-MOUNT EXPLODED VIEW

70-0351/0355

REF NO.	DESCRIPTION	PART NO.
1	CHASSIS	70-010261
2	COVER	70-010262
3	ANT PANEL	70-010313
4	CLIP	70-150126
5	PROGRAMMER PORT PACKING	70-157358
6	BRACKET	70-158323
7	CAP	70-150127
9	DUST PACKING	70-157428
11	PA SHIELD CASE	70-088345
12	PA SHIELD COVER	70-088340
13	VCO SHIELD CASE	70-088341
14	VCO SHIELD COVER	70-088342
15	LOG SHIELD CASE	70-088343
16	LOG SHIELD COVER	70-088344
24	VOLUME KNOB	70-110066
25	VOLUME KNOB	70-110067
26	SWITCH BUTTON	70-110065
32	CONTROL CASE ASSEMBLY	70-010260
33	CONTROL CHASSIS	70-010267
34	CONTROL COVER	70-010268
35	CONTROL BRACKET	70-158326
36	COIN SCREW	70-150130
37	FIBER WASHER	70-151363
38	RUBBER WASHER	70-151363
38	PCB GUIDE	70-150140
40	VOLUME BRACKET	70-158326
42	LED SPACER	70-150133
45	HANDLE	70-158325
46	HANDLE BASE	70-150132
48	BRACKET ASSY	70-158326
53	WASHER	70-150150
61	INSULATOR	70-157409
66	RING	70-150148
78	FE GROUND SPRING	70-152123
89	IF SHIELD	70-088366
101	SCREW PLAX PAN HD M3 x 10	70-150138
105	SCREW SEMS PAN HD M3 x 14	70-150191
106	SCREW SEMS M3 x 10	70-150180
107	SCREW SEMS M3 x 12	70-150151
110	FIXED SCREW PACK	70-000013
111	SCREW BIND HD M3 x 8	70-150146
CA401	CABLE ASSEMBLY	70-C34094
J301	NS1504L	70-159100
J311	D3431	70-159592
J321	D3431	70-159583
J501	M-PM	70-159080
SP301	SPEAKER	70-060033
G01	TRX, LOGIC PCB	TR-053
G02	MIC CONNECTOR PCB	CX-60
G03	DISPLAY PCB	CX-81
G04	OPERATE PCB	CX-82
G05	ADAPTOR (HANDLE) PCB	Z-593
G06	ADAPTOR (SMALL REMOTE)	Z-594

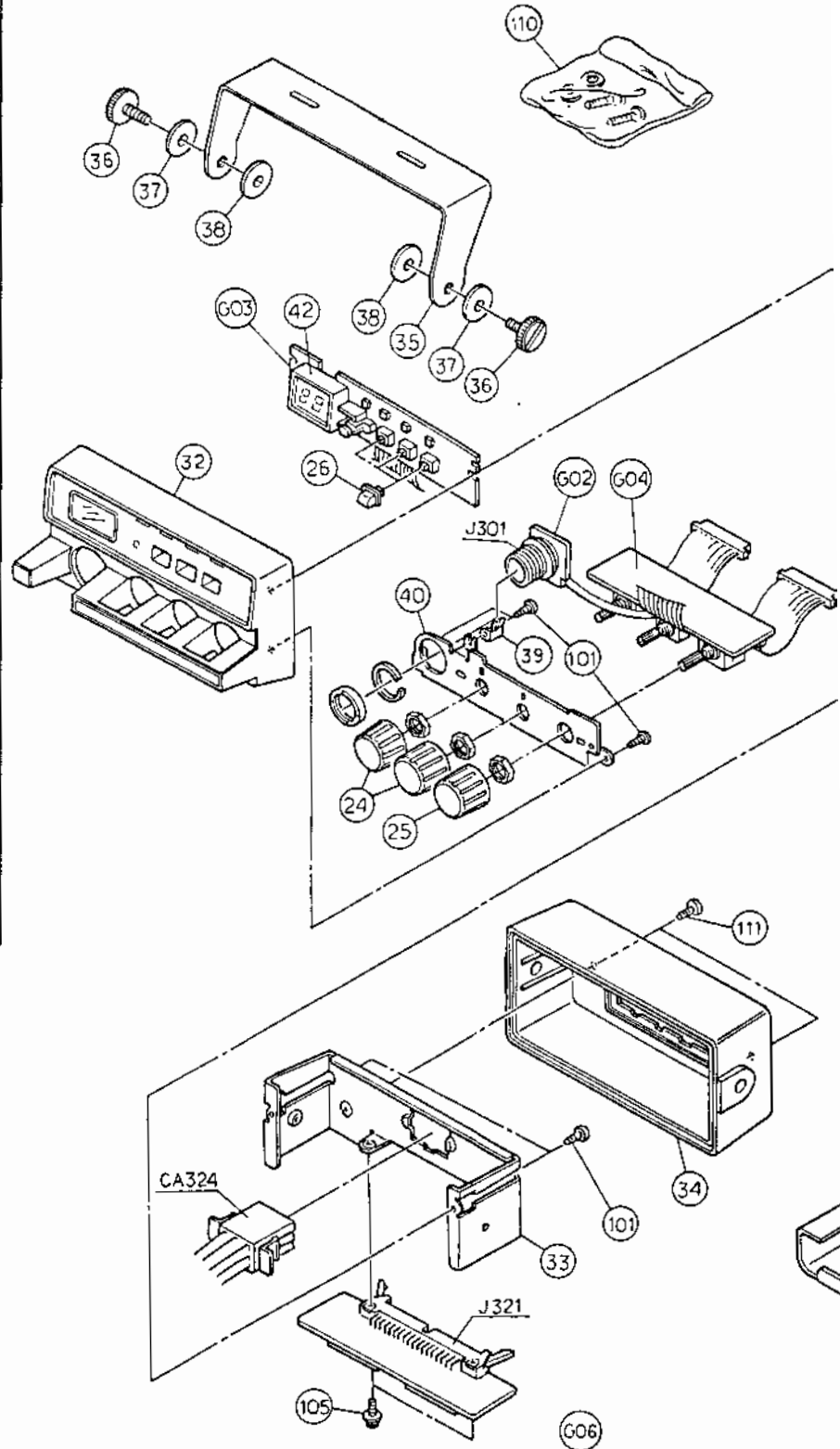

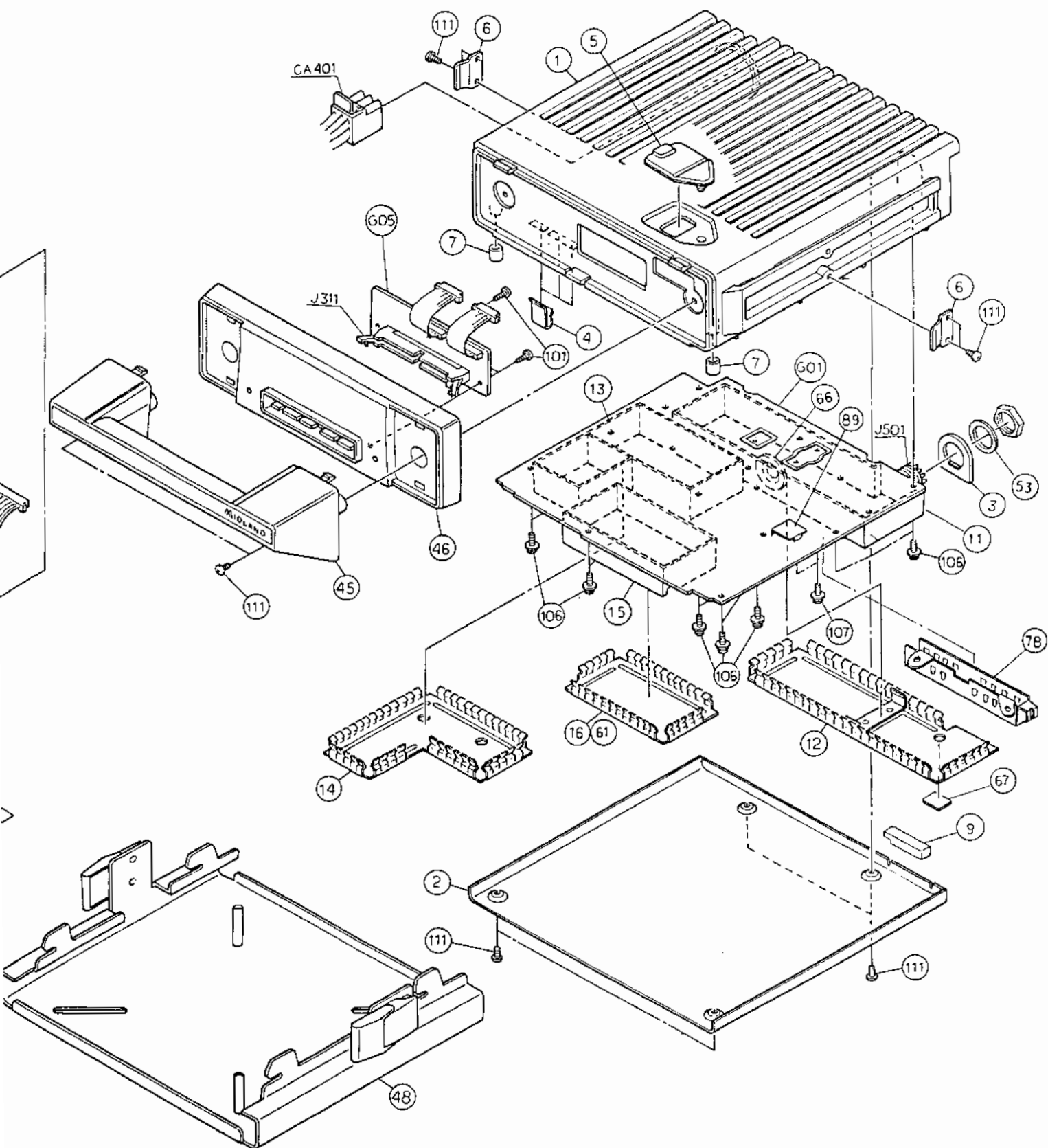

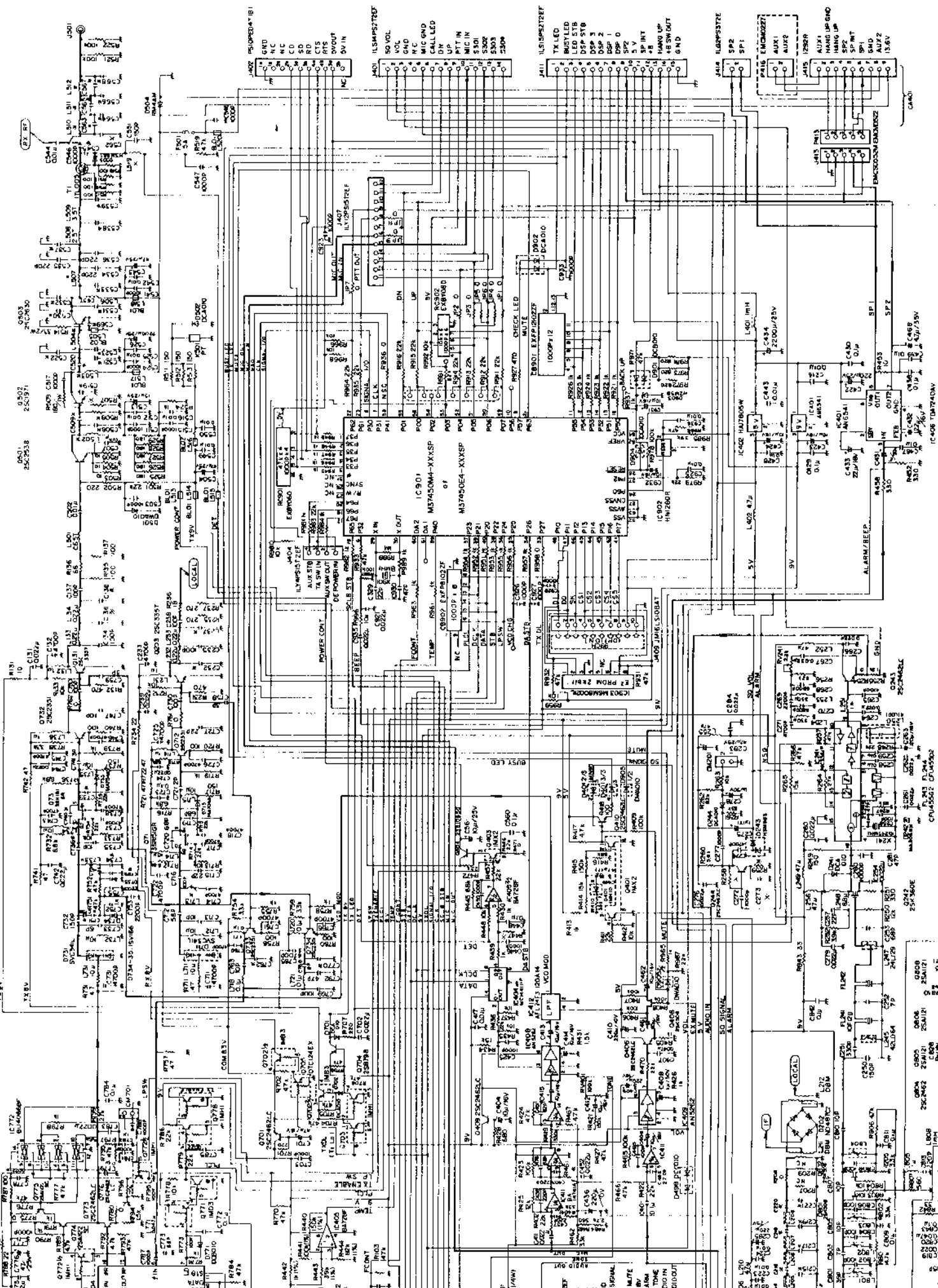

Part No.	Quantity	Description
IC901	1	M37450M4-XXASP
IC902	1	M37450E4-XXASP
IC903	1	M37450E4-XXASP
IC904	1	M37450E4-XXASP
IC905	1	M37450E4-XXASP
IC906	1	M37450E4-XXASP
IC907	1	M37450E4-XXASP
IC908	1	M37450E4-XXASP
IC909	1	M37450E4-XXASP
IC910	1	M37450E4-XXASP
IC911	1	M37450E4-XXASP
IC912	1	M37450E4-XXASP
IC913	1	M37450E4-XXASP
IC914	1	M37450E4-XXASP
IC915	1	M37450E4-XXASP
IC916	1	M37450E4-XXASP
IC917	1	M37450E4-XXASP
IC918	1	M37450E4-XXASP
IC919	1	M37450E4-XXASP
IC920	1	M37450E4-XXASP
IC921	1	M37450E4-XXASP
IC922	1	M37450E4-XXASP
IC923	1	M37450E4-XXASP
IC924	1	M37450E4-XXASP
IC925	1	M37450E4-XXASP
IC926	1	M37450E4-XXASP
IC927	1	M37450E4-XXASP
IC928	1	M37450E4-XXASP
IC929	1	M37450E4-XXASP
IC930	1	M37450E4-XXASP
IC931	1	M37450E4-XXASP
IC932	1	M37450E4-XXASP
IC933	1	M37450E4-XXASP
IC934	1	M37450E4-XXASP
IC935	1	M37450E4-XXASP
IC936	1	M37450E4-XXASP
IC937	1	M37450E4-XXASP
IC938	1	M37450E4-XXASP
IC939	1	M37450E4-XXASP
IC940	1	M37450E4-XXASP
IC941	1	M37450E4-XXASP
IC942	1	M37450E4-XXASP
IC943	1	M37450E4-XXASP
IC944	1	M37450E4-XXASP
IC945	1	M37450E4-XXASP
IC946	1	M37450E4-XXASP
IC947	1	M37450E4-XXASP
IC948	1	M37450E4-XXASP
IC949	1	M37450E4-XXASP
IC950	1	M37450E4-XXASP
IC951	1	M37450E4-XXASP
IC952	1	M37450E4-XXASP
IC953	1	M37450E4-XXASP
IC954	1	M37450E4-XXASP
IC955	1	M37450E4-XXASP
IC956	1	M37450E4-XXASP
IC957	1	M37450E4-XXASP
IC958	1	M37450E4-XXASP
IC959	1	M37450E4-XXASP
IC960	1	M37450E4-XXASP

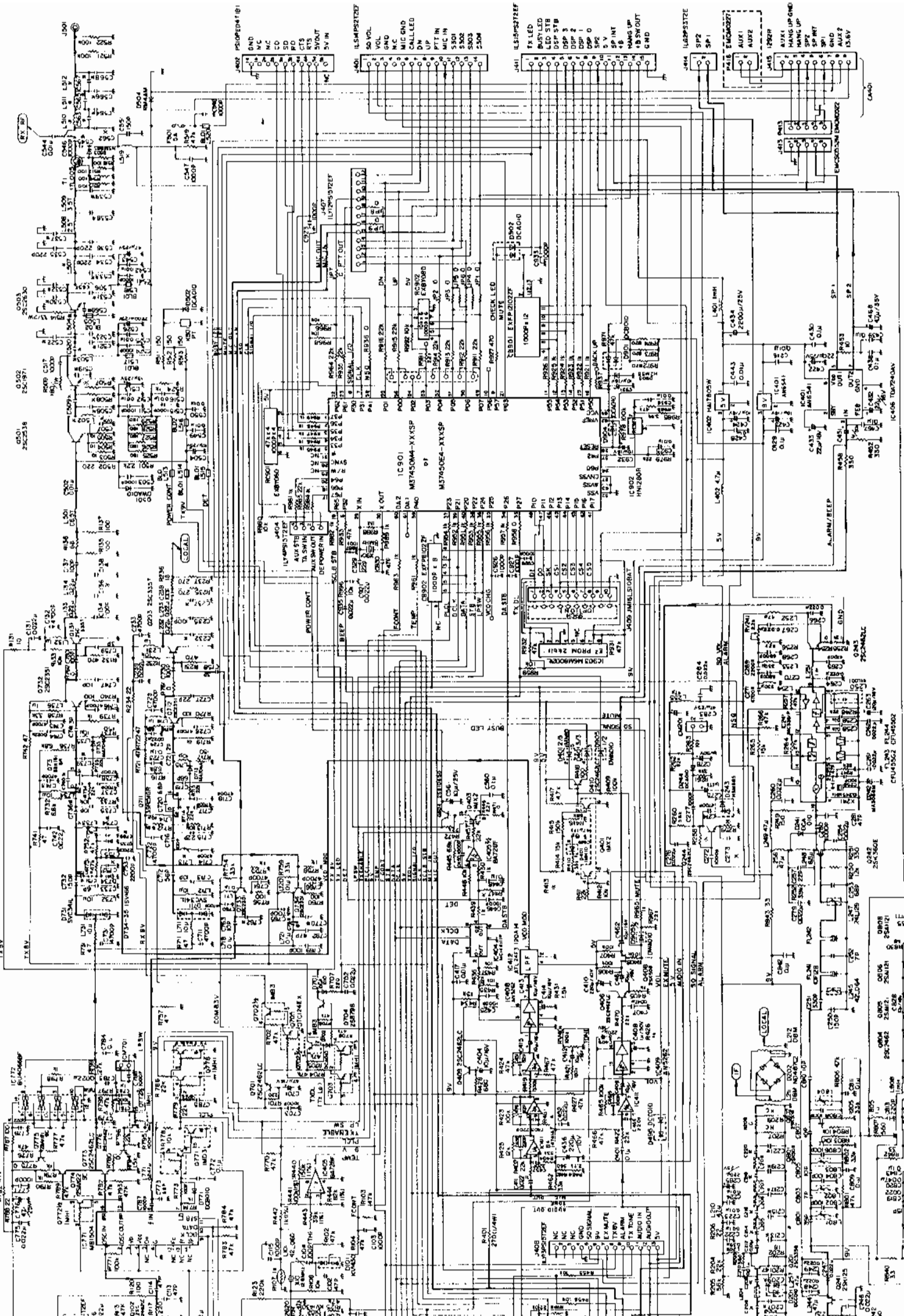

REF. NO.	DESCRIPTION	QTY	UNIT	MANUFACTURER	DATE	REVISION
A	RESISTOR	100	PCB	RESISTOR	1998	1.0
B	CAPACITOR	50	PCB	CAPACITOR	1998	1.0
C	IC	1	PCB	IC	1998	1.0
D	CONNECTOR	2	PCB	CONNECTOR	1998	1.0
E	WIRE	1000	PCB	WIRE	1998	1.0
F	DIODE	5	PCB	DIODE	1998	1.0
G	TRANSISTOR	10	PCB	TRANSISTOR	1998	1.0
H	RELAY	1	PCB	RELAY	1998	1.0
I	INDUCTOR	5	PCB	INDUCTOR	1998	1.0
J	OPTOCOUPLER	2	PCB	OPTOCOUPLER	1998	1.0
K	LED	10	PCB	LED	1998	1.0
L	SWITCH	5	PCB	SWITCH	1998	1.0
M	KEY	10	PCB	KEY	1998	1.0
N	BUZZER	1	PCB	BUZZER	1998	1.0
O	RELAY	1	PCB	RELAY	1998	1.0
P	DIODE	5	PCB	DIODE	1998	1.0
Q	TRANSISTOR	10	PCB	TRANSISTOR	1998	1.0
R	IC	1	PCB	IC	1998	1.0
S	CONNECTOR	2	PCB	CONNECTOR	1998	1.0
T	WIRE	1000	PCB	WIRE	1998	1.0
U	DIODE	5	PCB	DIODE	1998	1.0
V	TRANSISTOR	10	PCB	TRANSISTOR	1998	1.0
W	IC	1	PCB	IC	1998	1.0
X	CONNECTOR	2	PCB	CONNECTOR	1998	1.0
Y	WIRE	1000	PCB	WIRE	1998	1.0
Z	DIODE	5	PCB	DIODE	1998	1.0

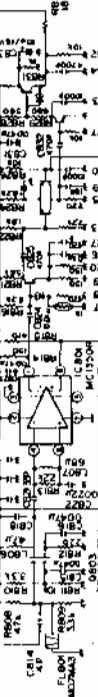

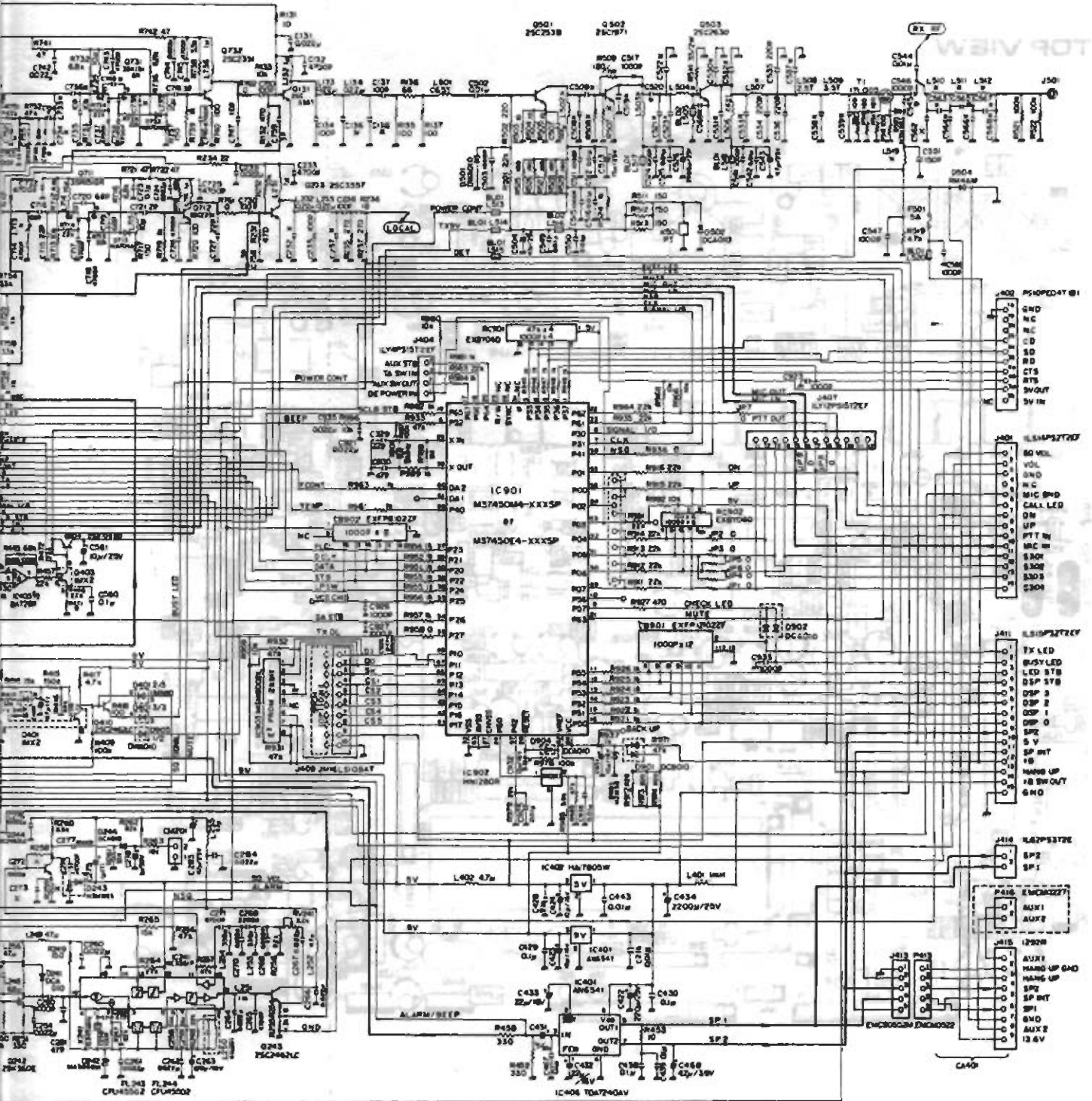

Pin	1	2	3	4	5	6	7	8	9	10	11	12	13	14	15	16	17	18	19	20	21	22	23	24	25	26	27	28	29	30	31	32	33	34	35	36	37	38	39	40	41	42	43	44	45	46	47	48	49	50
Pin 1	1	2	3	4	5	6	7	8	9	10	11	12	13	14	15	16	17	18	19	20	21	22	23	24	25	26	27	28	29	30	31	32	33	34	35	36	37	38	39	40	41	42	43	44	45	46	47	48	49	50
Pin 2	1	2	3	4	5	6	7	8	9	10	11	12	13	14	15	16	17	18	19	20	21	22	23	24	25	26	27	28	29	30	31	32	33	34	35	36	37	38	39	40	41	42	43	44	45	46	47	48	49	50
Pin 3	1	2	3	4	5	6	7	8	9	10	11	12	13	14	15	16	17	18	19	20	21	22	23	24	25	26	27	28	29	30	31	32	33	34	35	36	37	38	39	40	41	42	43	44	45	46	47	48	49	50

TR-053 SCHEMATIC DIAGRAM

70-0351/0355

